



# Circuit-breakers IZM up to 6300 A Switch-disconnectors IN up to 6300 A

With the new IZM series, Eaton presents a complete offering of air circuit-breakers (ACB) up to 6300 A. Five construction sizes make it possible to select the most economical switch for each project.

The new star is the circuit-breaker IZMX16. This innovative concept allows economical construction of two circuit-breakers within a field width of 600 mm.

There is no greater performance within such small space.

## Basic devices IZM

Switching capacity 440 V AC,  $I_{cu} = I_{cs}$  from 42 – 100 kA +++ 3 or 4 pole +++ electronic releases for system protection, selective and universal protection, universal protection with power measurement +++ rated operational current from 630 – 6300 A +++ rated operating voltage  $U_o$  1100 V for IZM32...3200-1100V

## High availability

Withdrawable units +IZM-CAS... +++ Main terminal kits IZM-T... +++ mechanical interlocks IZM-MIL...

## Comprehensive fixed mounted accessories

Motor operator IZM...M... +++ Shunt release IZM...ST... +++ Closing release IZM...-SR... +++ Undervoltage release IZM...-UV... +++ Auxiliary contact IZM...-AS... +++ Latch check switch IZM...LCS... +++ Trip indicator auxiliary switch IZM...-OTS +++ Mechanical interlocks

## Worldwide novelty ARMS™ – greater safety for maintenance personnel

If there is an accidental arc, the ARMS™ system (Arcflash Reduction Maintenance System) shuts down faster than a short circuit trip device. In connection with IZM, additional components from the accidental arc protection system ARCON provide incremental protection against accidental arcing.



### Eaton After Sales Service

Testing switching devices in compliance with regulations applicable to this technology  
→ Chapter 22

## Circuit-breakers IZMX16, switch-disconnectors INX16 from 630 A to 1600 A

### Technical overview

IZMX16 air circuit breakers	18/2
INX16 switch-disconnectors	18/2
Electronic releases for IZMX16 circuit-breakers	18/3

### System overview

IZMX16 circuit-breakers	18/4
Key to type references	18/5

### Description

IZMX16 air circuit-breaker, INX16 switch-disconnector	18/6
Components for IZMX16 communication	18/8

### Ordering

Basic devices	18/9
Compact air circuit-breakers, 3 and 4 pole	18/10
Withdrawable units	18/13
Cassettes, shutter (busbar tag shroud)	18/13
Electrical accessories	18/13
Motor operator	18/13
Operations counters, shunt releases	18/14
Auxiliary contact	18/15
Trip-indicating auxiliary switch, automatic reset	18/16
Locking facilities and locking devices	18/16
Options and accessories for trip units	18/17
Add-on functions for circuit-breakers Type V	18/17
Add-on functions for circuit-breakers Type U	18/17
Hand held tester for Digitrip	18/17
Communication modules	18/17
Rating plugs (Rate current modules)	18/18
Current sensor for neutral conductor	18/18
Main terminal kits, tunnel terminals	18/19
General accessories	18/19
Control circuit terminal blocks	18/19
Protective cover, blank cover for door cutout	18/19
Replacement coding, basic device to cassette	18/19
Replacement hand lever	18/19

### Engineering

Terminal assignment of control circuit terminals	18/20
Tripping characteristics	18/21
Rating plug combinations for IZMX16	18/25
Selectivity: incoming circuit-breaker, outgoing circuit-breaker	18/26

### Technical data

IZMX16 circuit-breakers	18/28
INX16 switch-disconnectors	18/32
Accessories for IZMX16	18/36

### Dimensions

Circuit-breaker IZMX16, switch-disconnector INX16	18/37
---	-------

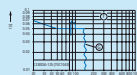

## Circuit-breaker IZM26, switch-disconnector IN26 from 800 A to 6300 A

### Technical overview

IZM 26 air circuit breakers	18/38
IN26 switch-disconnectors	18/39
Electronic releases for IZM26 circuit-breakers	18/40

### System overview

IZM26 circuit-breakers	18/42
Key to type references	18/43

### Description

Air circuit-breaker IZM26, IN26 switch-disconnector	18/44
Components for IZM26 communication	18/46

### Ordering

Basic devices	18/48
Air circuit-breakers, 3 and 4 pole	18/48
Air switch-disconnectors, 3 and 4 pole	18/60
Withdrawable units	18/62
Cassettes, shutter (busbar tag shroud)	18/62
Electrical accessories	18/64
Cell switches, motor operator, Operations counters	18/64
Shunt releases	18/65
Auxiliary contacts, latch check switch	18/67
Trip indication and reset options	18/67
Locking facilities and locking devices	18/68
Options and accessories for electronic releases trip units	18/70
Add-on function for electronic releases	18/70
Communication module, hand held tester	18/71
Rating plug sensor and current transformer	18/72
Current sensor for neutral conductor	18/74
Main terminal kits	18/75
General accessories	18/76
Control circuit terminal, door escutcheon with gasket	18/76
Protective cover, lifting yoke for lifting, Trolley	18/76

### Engineering

Terminal assignment of control circuit terminals	18/77
Switching states at mechanical interlock	18/77
Tripping characteristic	18/78
... for system protection	18/78
... for selectivity protection and universal protection	18/79
... for universal protection with power measurement	18/82
Rating plug combinations for IZM...	18/90
Selectivity: incoming circuit-breaker, outgoing circuit-breaker	18/92

### Technical data

IZM26 circuit-breakers	18/100
IN26 switch-disconnectors	18/108
Accessories for IZM26	18/116
Communication modules	18/118

### Dimensions

IZM26 circuit-breakers, IN26 switch-disconnectors	18/119
Minimum clearances	18/122



## IZMX16, INX16



<b><math>I_{cu}/I_{cs}</math> at <math>U_e = 440/690</math> V AC</b> $I_{cu}$ : Rated ultimate short-circuit breaking capacity at rated operational voltage $U_e$ $I_{cs}$ : Rated service short-circuit breaking capacity at rated operational voltage $U_e$		<b>Basic switching capacity (B)</b>		<b>Normal switching capacity (N)</b>		<b>High switching capacity (H)</b>	
		440 V AC	690 V AC	440 V AC	690 V AC	440 V AC	690 V AC
<b>Circuit-breakers</b>	Rated operational current $I_n$ A	$I_{cu} / I_{cs}$ kA/kA	$I_{cu} / I_{cs}$ kA/kA	$I_{cu} / I_{cs}$ kA/kA	$I_{cu} / I_{cs}$ kA/kA	$I_{cu} / I_{cs}$ kA/kA	$I_{cu} / I_{cs}$ kA/kA
<b>IZMX16</b>	630 - 1600	42/42	42/42	50/50	42/42	65/50	42/42

<b><math>I_{cw}</math> at <math>U_e = 440/690</math> V AC</b> $I_{cw}$ at $t = 1$ s $I_{cw}$ : Rated short-time withstand current		<b>Basic switching capacity (B)</b>		<b>Normal switching capacity (N)</b>		<b>High switching capacity (H)</b>	
		440/690 V AC	440/690 V AC	440/690 V AC	440/690 V AC	440/690 V AC	440/690 V AC
<b>Circuit-breaker, switch-disconnector</b>	Rated operational current $I_n$ A	$I_{cw}$ kA	$I_{cw}$ kA	$I_{cw}$ kA	$I_{cw}$ kA	$I_{cw}$ kA	$I_{cw}$ kA
<b>IZMX16</b>	630 - 1600	42	42	42	42	42	42

<b><math>I_{cm}</math> at <math>U_e = 440/690</math> V AC</b> $I_{cm}$ : Rated short-circuit making capacity (Peak value) at rated operational voltage $U_e$		<b>Basic switching capacity (B)</b>		<b>Normal switching capacity (N)</b>		<b>High switching capacity (H)</b>	
		440/690 V AC	440/690 V AC	440/690 V AC	440/690 V AC	440/690 V AC	440/690 V AC
<b>Switch-disconnector</b>	Rated operational current $I_n$ A	$I_{cm}$ kA	$I_{cw}$ kA	$I_{cw}$ kA	$I_{cw}$ kA	$I_{cw}$ kA	$I_{cw}$ kA
<b>INX 16</b>	630 - 1600	88	88	88	88	88	88



I ZMX16

	I ZMX16...A...	I ZMX16...V...	I ZMX16...U...
	System protection DTA Digitrip 520	Selectivity protection DTV Digitrip 520	Universal protection DTU Digitrip 520M
			
Current range	200 A - 1600 A	200 A - 1600 A	200 A - 1600 A
RMS value monitoring	●	●	●
<b>Protective functions</b>			
General			
Ordering options	LI	LSI, LSIG	LSI, LSIG, LSIA
Rating plug (I <sub>n</sub> )	●	●	●
Overtemperature trip	●	●	●
Overload protection	<b>L</b>		
Overload trip	(0.5 - 1.0) x I <sub>n</sub>	(0.5 - 1.0) x I <sub>n</sub>	(0.5 - 1.0) x I <sub>n</sub>
Delay time I <sup>2</sup> t at 6 x I <sub>r</sub>	2 - 24 s	2 - 24 s	2 - 24 s
Thermal memory	●	●	●
Short-time delayed short-circuit protection	<b>S</b>		
Delayed short-circuit protection	-	(2 - 10) x I <sub>r</sub>	(2 - 10) x I <sub>r</sub>
Short delay time I <sup>2</sup> t at 8 x I <sub>r</sub>	-	100 - 500 ms	100 - 500 ms
Short delay time, flat characteristic curve	-	100 - 500 ms	100 - 500 ms
Zone selectivity ZSI <sup>1)</sup>	○	○	○
Non-delayed short-circuit protection	<b>I</b>		
Non-delayed short-circuit protection	(2 - 10) x I <sub>n</sub>	(2 - 12) x I <sub>n</sub>	(2 - 12) x I <sub>n</sub>
Switch-off function	●	●	●
Closing releases MCR	●	●	●
Optional ground fault protection	<b>G</b>		
Ground/fault alarm	-	-	○ <sup>1)</sup>
Ground/fault protection release	-	(0.25 - 1.0) x I <sub>n</sub> <sup>3)</sup>	(0.25 - 1.0) x I <sub>n</sub> <sup>3)</sup>
Short delay time I <sup>2</sup> t at 0.625 x I <sub>n</sub>	100 - 500 ms	100 - 500 ms	100 - 500 ms
Short delay time, flat characteristic curve	100 - 500 ms	100 - 500 ms	100 - 500 ms
Zone selectivity ZSI <sup>1)</sup>	○	○	○
Thermal memory	●	●	●
Neutral conductor-conductor protection	<b>N</b>		
	●	●	●
<b>System diagnostics</b>			
Status/Overload LED	-	●	●
Cause of trip LEDs	-	●	●
Current at trip point (display indication)	-	-	● <sup>1)</sup>
Ground fault release/alarm remote signaling (relay contact)	<b>A</b>	-	● <sup>1)</sup>
Overload alarm monitoring	<b>A</b>	-	● <sup>1)</sup>
<b>System monitor</b>			
Digital display	-	-	4-digit LCD
<b>Field bus communication</b>			
	-	-	Optional: Modbus, PROFIBUS
<b>Additional functions</b>			
Test possibility <sup>2)</sup>	-	Hand held test unit	Hand held test unit
Maintenance mode ARMS (Arc Flash Reduction Maintenance System™)	-	-	○ <sup>1)</sup>

Notes

I<sub>n</sub> = rating plug (rate current module) = rated operational current current transformer  
I<sub>r</sub> = Set value overload trip (= rated operational current of system)

- <sup>1)</sup> Requires external 24 V DC control voltage supply.
- <sup>2)</sup> Hand-held tester for simulating of secondary current
- <sup>3)</sup> In combination with ARMS function limited to 1200 A.
- Standard
- Optional



System overview

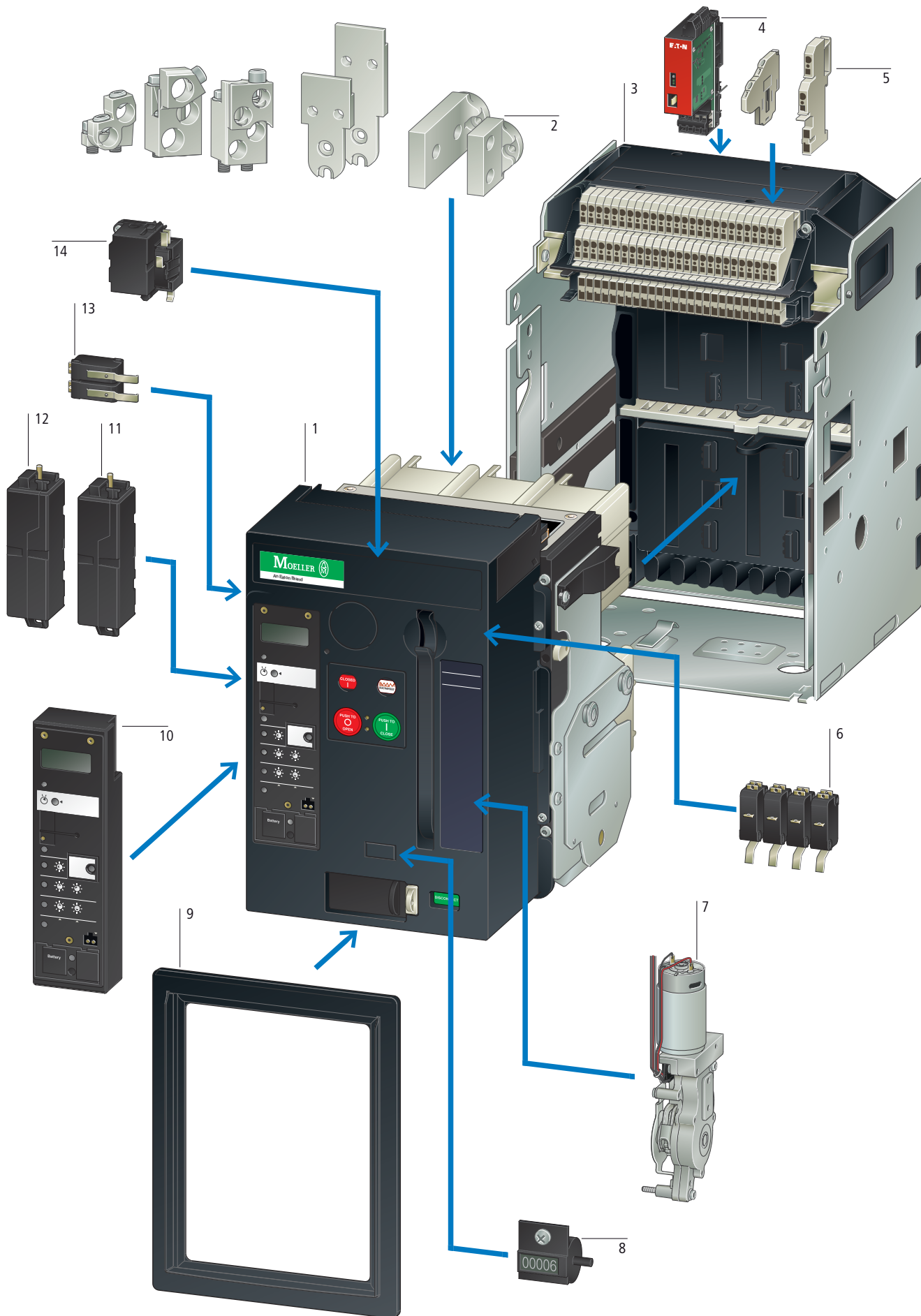

WWW.TM2A.PT info@tm2a.pt

WWW.TM2A.PT info@tm2a.pt



<b>IZMX16 circuit-breakers</b> 1 → Page 18/10	<b>Control circuit terminal units</b> 4 Either 8, 20 or 30 units → Page 18/19	<b>Switching operations counters</b> 7 → Page 18/14	<b>Shunt releases</b> 11 → Page 18/14
<b>Main terminal kits</b> 2 Universal terminals 3- and 4 pole, horizontal/vertical → Page 18/19	<b>Auxiliary contacts</b> 5 Signalling switch ON-OFF → Page 18/15	<b>Door escutcheon</b> 8 → Page 18/76	<b>Communication modules</b> 12 PROFIBUS-DP, Modbus → Page 18/8 → Page 18/17 → Page 18/71 → Page 18/118
<b>Cassette for withdrawable units</b> 3 Cassettes 1600 A With and without control circuit terminals → Page 18/13	<b>Motor operator</b> 6 Automatic charging of the stored energy mechanism for remote or local operations → Page 18/13	<b>Trip unit (Digitrip 520M)</b> 9 Type A circuit-breakers Type V circuit-breakers Type U circuit-breakers → Page 18/17	<b>Trip indication switches</b> 13 Overload trip switch (OTS), 2 C → Page 18/16
		<b>Undervoltage releases</b> 10 → Page 18/15	<b>Closing releases</b> 14 → Page 18/14

Key to type references

IZM	X16	B	3	-	A	06	W
IN		N	4		V	08	F
		H			U	10	
						12	
						16	

IZM, IN = Product family

Frame size

X16: Compact ACB, 630 - 1600 A

Switching capacity

B = Basic  
N = Normal  
H = High

Number of poles

3: 3 pole  
4: 4 pole

Trip type

A = System protection =  
Digitrip 520 LI  
V = Selective trip =  
Digitrip 520 LSI(G)  
U = Universal protection =  
Digitrip 520MC LSI(G)

Rated operational current

06: 630 A  
08: 800 A  
10: 1000 A  
12: 1250 A  
16: 1600 A

Model

W = Withdrawable units  
F = Fixed mounted



## Space-saving circuit-breakers with useful accessories

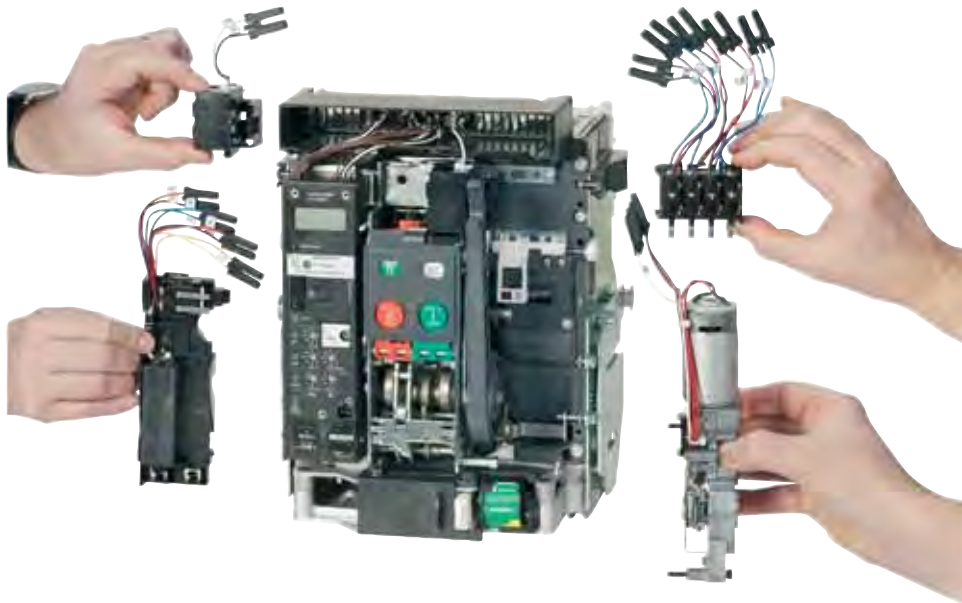

## IZMX16

The innovative concept of the IZMX16 makes it possible to install two withdrawable circuit-breakers in a 600 mm wide section. This enables more economical section design and also saves operating space. This additional performance in a minimum of space goes far beyond the standard available worldwide.

## Applications

The circuit-breakers can be used in four main application areas depending on the type of equipment to be protected:

- System protection,
- Motor protection,
- Transformer protection,
- Generator protection.

These key applications make different demands on the switches, which are met with a range of control units.

## Switches with closing release

They are particularly suitable for synchronization tasks.

## Coupler switches

Beside the IZMX16 circuit-breakers, INX16 switch-disconnectors are available. These are used, for example, as coupler switches between different power supplies.

## Modular design

The retrofitting of accessories is made considerably easy thanks to the efficient "plug & work" technology. Accessory drawers and snap-fit mechanisms makes it possible to fit the latest accessories with virtually no tools. This allows you to respond flexibly to changing requirements within your system.

## Standard scope of delivery as usual

- With the new IZMX16, you select a basic device that is already fitted with an electronic release.
- The standard mounting is on a horizontal mounting plate or on horizontal traverses in the switching cabinet. The IZMX16 can also be fastened to vertical mounting plates.
- With four-pole devices, the neutral conductor is arranged on the left (front view).
- The neutral conductor can be loaded 100% like the phase conductors.
- The circuit-breakers are provided with a standard mechanical reclosing lockout. After an overload trip, the fault is usually examined first of all. After the fault is identified and rectified, the mechanical reclosing lockout is reset by pressing the red mechanical trip indicator on the front of the circuit-breaker.
- An "Automatic Reset" can be ordered as an option. This enables the circuit-breaker to be restored to operation immediately at any time after the spring-operated stored energy mechanism is retensioned. In these applications compulsory fault analysis is intentionally avoided.
- The number of control cable terminals depends on the accessories fitted.
- If a cassette is ordered without the basic device, this can be already fitted with the maximum number of control cable terminals. For greater economy in large plants, the cassette is also offered without control circuit terminals so that fitting can be carried out later at the installation or when the required accessories are determined at a later time.
- 2 changeover contacts are provided as standard for ON/OFF status indication.
- A coding mechanism between the basic device and the cassette prevents impermissible combinations ("Rejection Interlock").

## Expanded standard scope of delivery for IZMX16

Some order types from the past can no longer be found since the following options are now already part of the standard scope of delivery:

- The door escutcheon is now always included in the scope of delivery. With withdrawable designs this is supplied with the cassette (withdrawable unit).
- On withdrawable units the circuit-breaker can be pulled out to inspect the arc chutes. With fixed units, it is recommended that sufficient space is provided above the circuit-breaker to enable inspection. An additional cover is not required.
- All basic devices that are provided with universal protection (with Digitrip 520M...), now feature a display.
- On each circuit-breaker the integrated Digitrip electronic release is factory fitted with a sealable protective cover.
- If a motor operator is ordered, the "Spring-operated stored energy mechanism tensioned" indicator switch is automatically provided.

## Other benefits of the IZMX16

- The design of the main terminal offers maximum flexibility. The horizontal terminal can be rotated simply at the installation so that it can also be used as a vertical connection. With withdrawable units, additional terminal pieces can even be dispensed with. The cassette of the IZMX16 offers an integrated flange terminal to which the system busbars can be connected directly. For this reason, the main terminal pieces for IZMX16 are not part of the standard scope of delivery. Don't forget to order additionally required terminal pieces if needed.
- Thanks to the separate mounting position, a switching operations counter can now be used also independently of a motor operator.
- Withdrawable unit operation: The unit is actuated with a hand crank supplied as a standard feature and has a secure position in the basic device. This is now possible also with a standard tool (square drive socket 1/4").

## External 24 V supply

- The standard protection functions of the IZMX16 operate generally independently of an external control voltage supply. The power supply of the electronics unit, for example for overload and short-circuit protection, is implemented via the current transformers integrated in the circuit-breaker.
- The universal release unit with display can be fed with a 24 V DC supply if required so that the display function can also be used without a load. An external 24 V DC power supply is needed if communication functions are required.

## IzMX16, INX16

### Communication capability

The communication-capability of the IzMX16 circuit-breakers open up new possibilities in power distribution. It provides all important operational information and passes this on. This increases system transparency and shortens the response times to states such as overcurrent, phase asymmetry and overvoltage.

A rapid intervention in a process can, for example, prevent downtimes and help to schedule maintenance activities and therefore boost plant availability.

A Modbus interface is offered as an alternative in addition to the Profibus interface.

### Greater safety for maintenance personnel with ARMS™

If the IzMX16 is fitted with the newly patented ARMS system (Arcflash Reduction Maintenance System™), a non-delayed immediate disconnection is ensured in the event of an arc fault. This disconnection is even faster than that of a non-delayed short-circuit release.

This function can be activated directly on the circuit-breaker or via an external switch, such as when maintenance personnel enter a hazardous area. Other components of the ARCON arc fault protection system, in conjunction with the IzMX16, enable an expansion of arc fault protection in stages. ARCON on the Internet: [www.moeller.net/arcon](http://www.moeller.net/arcon)

### Selection criteria for IzMX16 circuit-breakers

Fundamental criteria for the selection of circuit-breakers:

- Max short-circuit current  $I_{k\max}$  at the circuit-breaker' point of installation: this value determines the short-circuit breaking capacity or the short-circuit current carrying capacity of the circuit-breaker. It is compared with the  $I_{clur}$ ,  $I_{CS}$  and  $I_{Cw}$  values of the switch and essentially determines its size (see Technical data).
- Rated operational current  $I_n$  which should flow through the respective branch circuit: This value must not be greater than the maximum switch rated operational current of the circuit-breaker. The rated operational current can be adjusted down using additional rated operational current modules.
- Ambient temperature of the circuit-breaker: This is generally the internal temperature in the control panel. Observe the derating values with increased ambient temperature (see Technical data).
- Circuit-breaker type: fixed mounted or withdrawable units, 3 or 4 pole.
- Minimum short-circuit current, which flows through the switching device: The release must recognize this value as a short-circuit and may react with a trip.
- Protection functions of the circuit-breaker: This is determined by the selection of the respective over-current release.

### Documentation

Operating manual  
AWB1230-1628de (deutsch)  
AWB1230-1628en (english)

### CurveSelect characteristics program

Display characteristic curves according to specific settings and assess their interaction effectively: [www.moeller.net/de/support](http://www.moeller.net/de/support)





### Components for IZMX16 communication

For the IZMX16, PROFIBUS-DP or Modbus RTU are optionally available as fieldbus connections. Communication modules IZMX-PCAM and IZMX-MCAM are compact units for direct mounting in the auxiliary terminal strip. On retrofitting, four modular terminals are replaced with one communication module. This is possible for both for fixed and withdrawable units. The terminals provide all data available in the trip block to the fieldbus, including switching state, current, voltage, power, energy, and diagnostic information such as overcurrent, phase asymmetry and overvoltage. Through the bus the motor operator can also be remotely controlled.

### Requirements

The communications modules can be used in combination with IZMX16 circuit-breakers ....U or IZMX16....P... (in preparation) circuit-breakers.

### Configuration

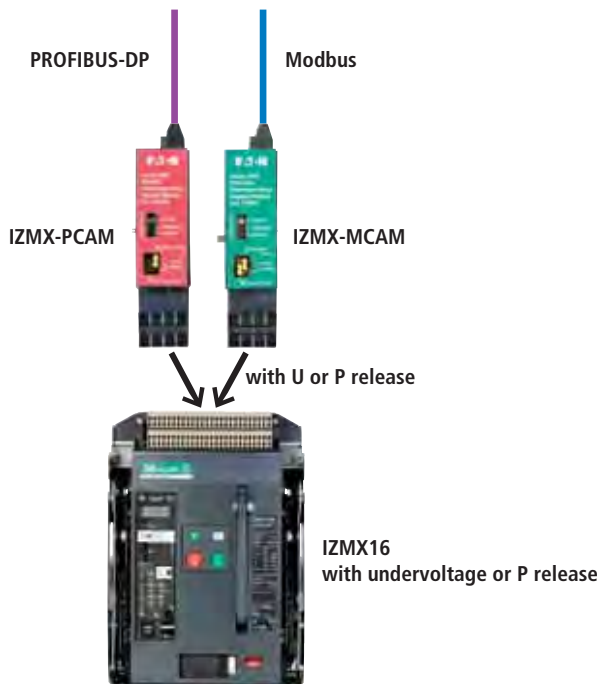

### PROFIBUS-DP configuration

Communications module IZMX-PCAM has a 9-pin D-Sub socket for connection to PROFIBUS. The module works as a slave on PROFIBUS-DP; the data is defined through a standardized device master data file, which permits smooth integration of IZMX in a DP line.

- On the PROFIBUS-DP side the module supports automatic baud rate detection; the PROFIBUS-DP bus address is set through the trip unit's display. The maximum cable length is 2.4 km.
- To operate the IZMX-PCAM, a supply voltage of 24 V DC is required.
- The data connection to the circuit-breaker is implemented internally through a serial high-speed data connection.

### Data access via PROFIBUS-DP

The data on PROFIBUS-DP are offered according to the profile for low-voltage switchgear (LVSG) of PROFIBUS International (PROFIBUS and PROFINET User Group). Five different data structures with varying numbers of parameters are available through the device master data file. This allows a data filter to be easily implemented, which simplifies integration of the IZM data into the control system.

### Modbus configuration

Communications module IZMX-MCAM has a plug-in screw terminal for connection to Modbus. The module operates as a Modbus slave.

- Baud rate, data format and address (max. 247) for Modbus are set with the input keys of the trip unit. The maximum cable length is 1.2 km.
- The Modbus must be terminated with a 120 Ω terminating resistor.
- To operate the IZMX-MCAM, a supply voltage of 24 V DC is required.
- The data connection to the circuit-breaker is implemented internally through a serial high-speed data connection.

### Data access via Modbus

The data is contained in comprehensive data tables. Each data point is available as floating-point (IEEE) or fixed-point value. This variance allows the integration of the IZMX to be adapted to the Modbus architecture. This enables a simple means of implementing a data filter, which facilitates the integration of IZMX data in the control system.

### Documentation

Operator manual  
For device series IZM26:  
AWB1230-1621de (deutsch)  
AWB1230-1621en (english)  
AWB1230-1622de (deutsch)  
AWB1230-1622en (english)

For device series IZMX16:  
AWB1230-1623de (deutsch)  
AWB1230-1623en (english)  
AWB1230-1624de (deutsch)  
AWB1230-1624en (english)

HPL18009EN

**IZMX16**

**Ordering**

Switching capacity $I_{cu}/I_{cs}$ kA/kA	Rated operational current $I_n = I_u$ A	Setting range		Fixed Part no. Article no.	Price See price list	Withdrawable Part no. Article no.	Price See price list	Std. pack	
		Overload releases $I_r$ A	Short-circuit releases Delayed $I_{sd} = I_r \times \dots$						Non-delayed $I_r = I_n \times \dots$
<p>3 pole Circuit-breakers for selective protection (Digitrip 520 M) Main terminals must be separately ordered.</p>									
42/42	630	315 - 630	—	2 - 10, OFF	IZMX16B3-A06F 123341	IZMX16B3-A06W 122818		1 off	
	800	400 - 800			IZMX16B3-A08F 123342	IZMX16B3-A08W 122819			
	1000	500 - 1000			IZMX16B3-A10F 123343	IZMX16B3-A10W 122820			
	1250	625 - 1250			IZMX16B3-A12F 123344	IZMX16B3-A12W 122849			
	1600	800 - 1600			IZMX16B3-A16F 123345	IZMX16B3-A16W 122850			
50/50	630	315 - 630			IZMX16N3-A06F 123366	IZMX16N3-A06W 123085			
	800	400 - 800			IZMX16N3-A08F 123367	IZMX16N3-A08W 123087			
	1000	500 - 1000			IZMX16N3-A10F 123368	IZMX16N3-A10W 123090			
	1250	625 - 1250			IZMX16N3-A12F 123369	IZMX16N3-A12W 123092			
	1600	800 - 1600			IZMX16N3-A16F 123370	IZMX16N3-A16W 123094			
65/50	630	315 - 630			IZMX16H3-A06F 123391	IZMX16H3-A06W 123141			
	800	400 - 800			IZMX16H3-A08F 123392	IZMX16H3-A08W 123142			
	1000	500 - 1000			IZMX16H3-A10F 123393	IZMX16H3-A10W 123143			
	1250	625 - 1250			IZMX16H3-A12F 123394	IZMX16H3-A12W 123144			
	1600	800 - 1600			IZMX16H3-A16F 123395	IZMX16H3-A16W 123145			
<p>4 pole Circuit-breakers for universal protection (Digitrip 520 M) Main terminals must be separately ordered.</p>									
42/42	630	315 - 630	—	2 - 10, OFF	IZMX16B4-A06F 123466	IZMX16B4-A06W 123201			1 off
	800	400 - 800			IZMX16B4-A08F 123467	IZMX16B4-A08W 123207			
	1000	500 - 1000			IZMX16B4-A10F 123468	IZMX16B4-A10W 123213			
	1250	625 - 1250			IZMX16B4-A12F 123469	IZMX16B4-A12W 123219			
	1600	800 - 1600			IZMX16B4-A16F 123470	IZMX16B4-A16W 123220			
50/50	630	315 - 630			IZMX16N4-A06F 123491	IZMX16N4-A06W 123241			
	800	400 - 800			IZMX16N4-A08F 123492	IZMX16N4-A08W 123242			
	1000	500 - 1000			IZMX16N4-A10F 123493	IZMX16N4-A10W 123243			
	1250	625 - 1250			IZMX16N4-A12F 123494	IZMX16N4-A12W 123244			
	1600	800 - 1600			IZMX16N4-A16F 123495	IZMX16N4-A16W 123245			
65/50	630	315 - 630			IZMX16H4-A06F 123516	IZMX16H4-A06W 123266			
	800	400 - 800			IZMX16H4-A08F 123517	IZMX16H4-A08W 123267			
	1000	500 - 1000			IZMX16H4-A10F 123518	IZMX16H4-A10W 123268			
	1250	625 - 1250			IZMX16H4-A12F 123519	IZMX16H4-A12W 123269			
	1600	800 - 1600			IZMX16H4-A16F 123525	IZMX16H4-A16W 123270			

WWW.TM2A.PT info@tm2a.pt

WWW.TM2A.PT info@tm2a.pt





Switching capacity $I_{cu}/I_{cs}$ kA/kA	Rated operational current $I_n = I_u$ A	Setting range Overload releases $I_r$ A	Short-circuit releases		Fixed Part no. Article no.	Price See price list	Withdrawable Part no. Article no.	Price See price list	Std. pack
			Delayed $I_{sd} = I_r \times \dots$	Non-delayed $I_i = I_n \times \dots$					
							Cassette must be ordered separately.		
3 pole circuit-breaker for selective protection Main terminals must be separately ordered.									
42/42	630	315 – 630	2 - 10	2 - 12, OFF	<b>I<sub>ZM</sub>X16B3-V06F</b> 123346		<b>I<sub>ZM</sub>X16B3-V06W</b> 122851		1 off
	800	400 – 800			<b>I<sub>ZM</sub>X16B3-V08F</b> 123347		<b>I<sub>ZM</sub>X16B3-V08W</b> 122918		
	1000	500 – 1000			<b>I<sub>ZM</sub>X16B3-V10F</b> 123348		<b>I<sub>ZM</sub>X16B3-V10W</b> 122920		
	1250	625 – 1250			<b>I<sub>ZM</sub>X16B3-V12F</b> 123349		<b>I<sub>ZM</sub>X16B3-V12W</b> 122922		
	1600	800 – 1600			<b>I<sub>ZM</sub>X16B3-V16F</b> 123350		<b>I<sub>ZM</sub>X16B3-V16W</b> 122924		
50/50	630	315 – 630			<b>I<sub>ZM</sub>X16N3-V06F</b> 123371		<b>I<sub>ZM</sub>X16N3-V06W</b> 123097		
	800	400 – 800			<b>I<sub>ZM</sub>X16N3-V08F</b> 123372		<b>I<sub>ZM</sub>X16N3-V08W</b> 123099		
	1000	500 – 1000			<b>I<sub>ZM</sub>X16N3-V10F</b> 123373		<b>I<sub>ZM</sub>X16N3-V10W</b> 123101		
	1250	625 – 1250			<b>I<sub>ZM</sub>X16N3-V12F</b> 123374		<b>I<sub>ZM</sub>X16N3-V12W</b> 123103		
	1600	800 – 1600			<b>I<sub>ZM</sub>X16N3-V16F</b> 123375		<b>I<sub>ZM</sub>X16N3-V16W</b> 123106		
65/50	630	315 – 630			<b>I<sub>ZM</sub>X16H3-V06F</b> 123396		<b>I<sub>ZM</sub>X16H3-V06W</b> 123146		
	800	400 – 800			<b>I<sub>ZM</sub>X16H3-V08F</b> 123397		<b>I<sub>ZM</sub>X16H3-V08W</b> 123147		
	1000	500 – 1000			<b>I<sub>ZM</sub>X16H3-V10F</b> 123398		<b>I<sub>ZM</sub>X16H3-V10W</b> 123148		
	1250	625 – 1250			<b>I<sub>ZM</sub>X16H3-V12F</b> 123399		<b>I<sub>ZM</sub>X16H3-V12W</b> 123149		
	1600	800 – 1600			<b>I<sub>ZM</sub>X16H3-V16F</b> 123405		<b>I<sub>ZM</sub>X16H3-V16W</b> 123150		
4 pole circuit-breakers for universal protection (Digitrip 520 M) Main terminals must be separately ordered.									
42/42	630	315 – 630	2 - 10	2 - 12, OFF	<b>I<sub>ZM</sub>X16B4-V06F</b> 123471		<b>I<sub>ZM</sub>X16B4-V06W</b> 123221		1 off
	800	400 – 800			<b>I<sub>ZM</sub>X16B4-V08F</b> 123472		<b>I<sub>ZM</sub>X16B4-V08W</b> 123222		
	1000	500 – 1000			<b>I<sub>ZM</sub>X16B4-V10F</b> 123473		<b>I<sub>ZM</sub>X16B4-V10W</b> 123223		
	1250	625 – 1250			<b>I<sub>ZM</sub>X16B4-V12F</b> 123474		<b>I<sub>ZM</sub>X16B4-V12W</b> 123224		
	1600	800 – 1600			<b>I<sub>ZM</sub>X16B4-V16F</b> 123475		<b>I<sub>ZM</sub>X16B4-V16W</b> 123225		
50/50	630	315 – 630			<b>I<sub>ZM</sub>X16N4-V06F</b> 123496		<b>I<sub>ZM</sub>X16N4-V06W</b> 123246		
	800	400 – 800			<b>I<sub>ZM</sub>X16N4-V08F</b> 123497		<b>I<sub>ZM</sub>X16N4-V08W</b> 123247		
	1000	500 – 1000			<b>I<sub>ZM</sub>X16N4-V10F</b> 123498		<b>I<sub>ZM</sub>X16N4-V10W</b> 123248		
	1250	625 – 1250			<b>I<sub>ZM</sub>X16N4-V12F</b> 123499		<b>I<sub>ZM</sub>X16N4-V12W</b> 123249		
	1600	800 – 1600			<b>I<sub>ZM</sub>X16N4-V16F</b> 123500		<b>I<sub>ZM</sub>X16N4-V16W</b> 123250		
65/50	630	315 – 630			<b>I<sub>ZM</sub>X16H4-V06F</b> 123531		<b>I<sub>ZM</sub>X16H4-V06W</b> 123271		
	800	400 – 800			<b>I<sub>ZM</sub>X16H4-V08F</b> 123537		<b>I<sub>ZM</sub>X16H4-V08W</b> 123272		
	1000	500 – 1000			<b>I<sub>ZM</sub>X16H4-V10F</b> 123543		<b>I<sub>ZM</sub>X16H4-V10W</b> 123273		
	1250	625 – 1250			<b>I<sub>ZM</sub>X16H4-V12F</b> 123549		<b>I<sub>ZM</sub>X16H4-V12W</b> 123274		
	1600	800 – 1600			<b>I<sub>ZM</sub>X16H4-V16F</b> 123555		<b>I<sub>ZM</sub>X16H4-V16W</b> 123275		

WWW.TM2A.PT info@tm2a.pt

WWW.TM2A.PT info@tm2a.pt



Switching capacity $I_{cu}/I_{cs}$ kA/kA	Rated operational current $I_n = I_u$ A	Setting range Overload releases $I_r$ A 	Short-circuit releases		Fixed Part no. Article no.	Price See price list	Withdrawable Part no. Article no.  Cassette must be ordered separately.	Price See price list	Std. pack
			Delayed $I_{sd} = I_r \times \dots$ 	Non-delayed $I_i = I_n \times \dots$ 					
<b>3 pole circuit-breakers for universal protection (Digitrip M)</b> Main terminals must be separately ordered.									
42/42	630	315 – 630	2 - 10	2 - 12, OFF	<b>I ZMX16B3-U06F</b> 123351		<b>I ZMX16B3-U06W</b> 122940		1 off
	800	400 – 800			<b>I ZMX16B3-U08F</b> 123352		<b>I ZMX16B3-U08W</b> 122941		
	1000	500 – 1000			<b>I ZMX16B3-U10F</b> 123353		<b>I ZMX16B3-U10W</b> 122979		
	1250	625 – 1250			<b>I ZMX16B3-U12F</b> 123354		<b>I ZMX16B3-U12W</b> 122984		
	1600	800 – 1600			<b>I ZMX16B3-U16F</b> 123355		<b>I ZMX16B3-U16W</b> 123020		
50/50	630	315 – 630			<b>I ZMX16N3-U06F</b> 123376		<b>I ZMX16N3-U06W</b> 123109		
	800	400 – 800			<b>I ZMX16N3-U08F</b> 123377		<b>I ZMX16N3-U08W</b> 123111		
	1000	500 – 1000			<b>I ZMX16N3-U10F</b> 123378		<b>I ZMX16N3-U10W</b> 123114		
	1250	625 – 1250			<b>I ZMX16N3-U12F</b> 123379		<b>I ZMX16N3-U12W</b> 123129		
	1600	800 – 1600			<b>I ZMX16N3-U16F</b> 123380		<b>I ZMX16N3-U16W</b> 123130		
65/50	630	315 – 630			<b>I ZMX16H3-U06F</b> 123411		<b>I ZMX16H3-U06W</b> 123151		
	800	400 – 800			<b>I ZMX16H3-U08F</b> 123417		<b>I ZMX16H3-U08W</b> 123152		
	1000	500 – 1000			<b>I ZMX16H3-U10F</b> 123423		<b>I ZMX16H3-U10W</b> 123153		
	1250	625 – 1250			<b>I ZMX16H3-U12F</b> 123429		<b>I ZMX16H3-U12W</b> 123154		
	1600	800 – 1600			<b>I ZMX16H3-U16F</b> 123435		<b>I ZMX16H3-U16W</b> 123155		
<b>4 pole circuit-breakers for selective protection (Digitrip 520 M LSI)</b> Main terminals must be separately ordered.									
42/42	630	315 – 630	2 - 10	2 - 12, OFF	<b>I ZMX16B4-U06F</b> 123476		<b>I ZMX16B4-U06W</b> 123226		1 off
	800	400 – 800			<b>I ZMX16B4-U08F</b> 123477		<b>I ZMX16B4-U08W</b> 123227		
	1000	500 – 1000			<b>I ZMX16B4-U10F</b> 123478		<b>I ZMX16B4-U10W</b> 123228		
	1250	625 – 1250			<b>I ZMX16B4-U12F</b> 123479		<b>I ZMX16B4-U12W</b> 123229		
	1600	800 – 1600			<b>I ZMX16B4-U16F</b> 123480		<b>I ZMX16B4-U16W</b> 123230		
50/50	630	315 – 630			<b>I ZMX16N4-U06F</b> 123501		<b>I ZMX16N4-U06W</b> 123251		
	800	400 – 800			<b>I ZMX16N4-U08F</b> 123502		<b>I ZMX16N4-U08W</b> 123252		
	1000	500 – 1000			<b>I ZMX16N4-U10F</b> 123503		<b>I ZMX16N4-U10W</b> 123253		
	1250	625 – 1250			<b>I ZMX16N4-U12F</b> 123504		<b>I ZMX16N4-U12W</b> 123254		
	1600	800 – 1600			<b>I ZMX16N4-U16F</b> 123505		<b>I ZMX16N4-U16W</b> 123255		
65/50	630	315 – 630			<b>I ZMX16H4-U06F</b> 123561		<b>I ZMX16H4-U06W</b> 123276		
	800	400 – 800			<b>I ZMX16H4-U08F</b> 123567		<b>I ZMX16H4-U08W</b> 123277		
	1000	500 – 1000			<b>I ZMX16H4-U10F</b> 123573		<b>I ZMX16H4-U10W</b> 123278		
	1250	625 – 1250			<b>I ZMX16H4-U12F</b> 123579		<b>I ZMX16H4-U12W</b> 123279		
	1600	800 – 1600			<b>I ZMX16H4-U16F</b> 123580		<b>I ZMX16H4-U16W</b> 123285		

WWW.TM2A.PT info@tm2a.pt

WWW.TM2A.PT info@tm2a.pt



Rated short-circuit making capacity $I_{cm}$ kA	Rated operational current $I_n = I_u$ A	Rated short-time withstand current $t = 1$ s $I_{cw}$ kA	Fixed Part no. Article no.	Price See price list	Withdrawable Part no. Article no. Cassette must be separately ordered.	Price See price list	Std. pack
<b>3 pole switch-disconnectors:</b> Main terminals must be separately ordered.							
88	630	42	<b>INX16B3-06F</b> 123361		<b>INX16B3-06W</b> 123073		1 off
	800		<b>INX16B3-08F</b> 123362		<b>INX16B3-08W</b> 123076		
	1000		<b>INX16B3-10F</b> 123363		<b>INX16B3-10W</b> 123078		
	1250		<b>INX16B3-12F</b> 123364		<b>INX16B3-12W</b> 123080		
	1600		<b>INX16B3-16F</b> 123365		<b>INX16B3-16W</b> 123083		
	<b>4 pole switch-disconnectors:</b> Main terminals must be separately ordered.						
88	630	42	<b>INX16B4-06F</b> 123486		<b>INX16B4-06W</b> 123236		1 off
	800		<b>INX16B4-08F</b> 123487		<b>INX16B4-08W</b> 123237		
	1000		<b>INX16B4-10F</b> 123488		<b>INX16B4-10W</b> 123238		
	1250		<b>INX16B4-12F</b> 123489		<b>INX16B4-12W</b> 123239		
	1600		<b>INX16B4-16F</b> 123490		<b>INX16B4-16W</b> 123240		

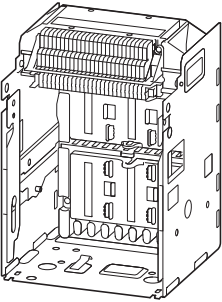
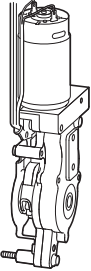

Rated operational current $I_n$ A	Rated ultimate short-circuit breaking capacity $I_{cu}$ kA	Pole	For use with	Part no. Article no.  Part no. suffix "+IZM..." Article no. for ordering with basic device	Price See price list	Std. pack	Notes
<b>Withdrawable units</b>							
<b>Cassettes</b>							
Equipment supplied: arcing chamber cover, coding to basic device							
	$\leq 1600$	$\leq 65$	3	IZMX16...3-...W INX16...3-...W	<b>IZMX-CAS163-1600</b> 101537	1 off	Without control circuit terminals
					<b>+IZMX-CAS163-1600</b> 101536		With control circuit terminals according to ordered options
					<b>IZMX-CAS163-1600-SEC</b> 123986		Fully equipped with control circuit terminals
					<b>IZMX-CAS164-1600</b> 101539		Without control circuit terminals
					<b>+IZMX-CAS164-1600</b> 101538		With control circuit terminals according to ordered options
					<b>IZMX-CAS164-1600-SEC</b> 124175		Fully equipped with control circuit terminals
<b>Shutter protection against direct contact</b> When the switch is withdrawn from its connected position, the shutters automatically cover the cassette's live main terminals.							
$800 - 1600$	-	3	(+)IZMX-CAS163...	<b>IZMX-SH163</b> 101542		1 off	-
				<b>+IZMX-SH163</b> 101541			
		4	(+)IZMX-CAS164...	<b>IZMX-SH164</b> 101544			
				<b>+IZMX-SH164</b> 101543			
Rated control voltage $U_s$ V	For use with	Part no. Article no.  Part no. suffix "+IZM..." Article no. for ordering with basic device	Price See price list	Std. pack	Notes		
<b>Motor operator</b>							
The motor automatically tensions the spring-operated stored energy mechanism for remote or local actuation. A signaling switch for the "Spring-operated stored energy mechanism tensioned" message is included as standard.							
	24 DC	IZMX16... INX16...	<b>IZMX-M16-24DC</b> 123594	1 off	For retrofitting, two additional control circuit terminal blocks are required. → Page 18/19		
	24 DC	IZMX16... INX16...	<b>+IZMX-M16-24DC</b> 123593				
	48 DC	IZMX16... INX16...	<b>IZMX-M16-48DC</b> 123596				
	48 DC	IZMX16... INX16...	<b>+IZMX-M16-48DC</b> 123595				
	110 - 125 DC	IZMX16... INX16...	<b>IZMX-M16-110DC</b> 123598				
	110 - 125 DC	IZMX16... INX16...	<b>+IZMX-M16-110DC</b> 123597				
	220 - 250 DC	IZMX16... INX16...	<b>IZMX-M16-220DC</b> 123600				
	220 - 250 DC	IZMX16... INX16...	<b>+IZMX-M16-220DC</b> 123599				
	110 - 127 AC	IZMX16... INX16...	<b>IZMX-M16-110AC</b> 123602				
	110 - 127 AC	IZMX16... INX16...	<b>+IZMX-M16-110AC</b> 123601				
	220 - 240 AC	IZMX16... INX16...	<b>IZMX-M16-230AC</b> 123604				
	220 - 240 AC	IZMX16... INX16...	<b>+IZMX-M16-230AC</b> 123603				

WWW.TM2A.PT info@tm2a.pt

WWW.TM2A.PT info@tm2a.pt

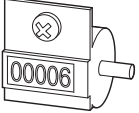
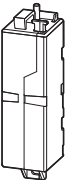
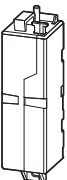
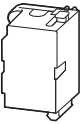

	Rated control voltage $U_s$ V	For use with	Part no. Article no.  Part no. suffix "+IZM..." Article no. for ordering with basic device	Price See price list	Std. pack	Notes
<b>Switching operations counter</b>						
Counts the number of On-Off operations. Can also be installed without motor operator.						
	-	IZMX16... INX16...	<b>IZMX-OC16</b> 123606		1 off	-
	-	IZMX16... INX16...	<b>+IZMX-OC16</b> 123605		1 off	-
<b>Voltage releases</b>						
A closing release can be combined with a voltage release and an undervoltage release or with two voltage releases.						
<b>Shunt releases</b>						
	24 DC	IZMX16... INX16...	<b>IZMX-ST24DC</b> 123608		1 off	An additional control circuit terminal block is required for retrofitting. → Page 18/19
			<b>+IZMX-ST24DC</b> 123607			
	48 DC		<b>IZMX-ST48DC</b> 123656			
			<b>+IZMX-ST48DC</b> 123616			
	110 - 125 DC 110 - 127 AC	<b>IZMX-ST110AD</b> 123728				
		<b>+IZMX-ST110AD</b> 123696				
	220 - 250 DC 208 - 240 AC	<b>IZMX-ST230AD</b> 123730				
		<b>+IZMX-ST230AD</b> 123729				
<b>2nd shunt release</b> Cannot be combined with an undervoltage release.						
	24 DC	IZMX16... INX16...	<b>+IZMX-STs24DC</b> 123731		1 off	An additional control circuit terminal block is required for retrofitting. → Page 18/19
			<b>+IZMX-STs48DC</b> 123732			
	110 - 125 DC 110 - 127 AC		<b>+IZMX-STs110AD</b> 123733			
			<b>+IZMX-STs230AD</b> 123734			
	220 - 250 DC 208 - 240 AC					
<b>Closing releases without latch check switch</b>						
	24 DC	IZMX16... INX16...	<b>IZMX-SR24DC</b> 123736		1 off	An additional control circuit terminal block is required for retrofitting. → Page 18/19
			<b>+IZMX-SR24DC</b> 123735			
	48 DC		<b>IZMX-SR48DC</b> 123738			
			<b>+IZMX-SR48DC</b> 123737			
	110 - 125 DC 110 - 127 AC	<b>IZMX-SR110AD</b> 123740				
		<b>+IZMX-SR110AD</b> 123739				
	220 - 250 DC 208 - 240 AC	<b>IZMX-SR230AD</b> 123742				
		<b>+IZMX-SR230AD</b> 123741				

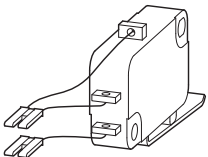
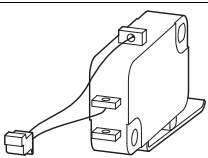
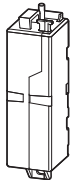
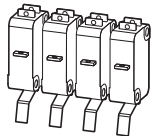
	Rated control voltage U <sub>s</sub> V	For use with	Part no. Article no.  Part no. suffix "+IZM..." Article no. for ordering with basic device	Price See price list	Std. pack	Notes
<b>Voltage releases</b>						
Latch check switch, 1 changeover contact						
	-	IZMX16... INX16...	<b>IZMX-LCS16</b> 123885		1 off	For external application
	-		<b>+IZMX-LCS16</b> 123884			
	-		<b>IZMX-LCS16-SR</b> 123887			For use with closing release IZMX16-SR...
	-		<b>+IZMX-LCS16-SR</b> 123886			
<b>Under voltage release</b> Cannot be combined with a second voltage release.						
	24 DC	IZMX16... INX16...	<b>IZMX-UVR24DC</b> 123744		1 off	An additional control circuit terminal block is required for retrofitting. → Page 18/19
			<b>+IZMX-UVR24DC</b> 123743			
	48 DC		<b>IZMX-UVR48DC</b> 123748			
			<b>+IZMX-UVR48DC</b> 123747			
	110 - 125 DC 110 - 127 AC		<b>IZMX-UVR110AD</b> 123801			
			<b>+IZMX-UVR110AD</b> 123761			
	220 - 250 DC 208 - 240 AC		<b>IZMX-UVR220AD</b> 123873			
			<b>+IZMX-UVR220AD</b> 123841			
<b>Auxiliary contacts</b>						
Standard auxiliary switch for On-Off signaling The basic device already contains two changeover contacts. Two additional changeover contacts possible.						
	-	IZMX16... INX16...	<b>IZMX-AS22</b> 123881		1 off	Three additional control circuit terminal blocks are required for retrofitting. → Page 18/19
			<b>+IZMX-AS22</b> 123880			

WWW.TM2A.PT info@tm2a.pt

WWW.TM2A.PT info@tm2a.pt



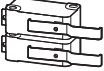

For use with	Part no. Article no.	Price See price list	Std. pack	Notes
<b>Trip indication and reset options</b>				
Trip-indicating auxiliary switch Overcurrent trip switch (OTS) with two changeover contacts.				
 IZMX16...	<b>IZMX-OTS</b> 123889		1 off	Three additional control circuit terminal blocks are required for retrofitting.
	<b>+IZMX-OTS</b> 123888			
Automatic reset The switch can be switched on again immediately after a trip. The switch does not contain the mechanical trip-indicator (red pin). Cannot be combined with remote reset.				
IZMX16...	<b>IZMX-RA</b> 123898		1 off	–
	<b>+IZMX-RA</b> 123897			–
<b>Locking facilities</b>				
Locking of ON/OFF buttons Padlockable front cover for On-Off pushbutton.				
IZMX16... INX16...	<b>IZMX-PLPC16</b> 123946		1 off	–
	<b>+IZMX-PLPC16</b> 123906			–
Key locking in safe Off The "Safe Off" locking feature prevents switching on. Neither remote nor local switching on is possible.				
IZMX16... INX16...	<b>IZMX-KLP-SO16-CASTELL</b> 124184		1 off	Castell installation kit without lock cylinder.
	<b>IZMX-KLP-SO16-RONIS</b> 124186			Ronis installation kit without lock cylinder.
	<b>IZMX-KLP-SO16-KIRK</b> 126481			Kirk installation kit without lock cylinder.
	<b>IZMX-KLP-SO16-CES</b> 126479			CES installation kit without lock cylinder.



HPL18017EN

I ZMX-DTA, I ZMX-DTV..., I ZMX-DTU..., I ZM-TEST, I ZMX-M(P)CAM...

	Rated control voltage U <sub>s</sub> V	For use with	Part no. Article no.  Part no. suffix "+IZM..." Article no. for ordering with basic device	Price See price list	Std. pack	Notes
<b>Options and accessories for trip units</b>						
Trip unit for system protection Type A (Digitrip 520)	–		<b>IZMX-DTA</b> 124012		1 off	–
Control unit for selective protection	–		<b>IZMX-DTV</b> 124013		1 off	–
<b>Add-on functions for Type V circuit-breakers (equipped with Digitrip 520LSI)</b>						
Ground fault protection	–	I ZMX16...-V... (Digitrip 520LSI)	<b>+IZMX-DTV-EP</b> 124016		1 off	–
Zone selectivity Zone selectivity shortens the stagger times in the range of the delayed short-circuit protection.	–	I ZMX16...-V... (Digitrip 520LSI)	<b>+IZMX-DTV-ZSI</b> 124017		1 off	–
Control unit for universal protection	–		<b>IZMX-DTU</b> 124014		1 off	–
<p>Standard for all circuit-breakers Type U:</p> <ul style="list-style-type: none"> <li>• Display</li> <li>• Communication-capability</li> <li>• Overload alarm signal</li> </ul> <p>Instead of the overload alarm (HLA) either the function ground-fault protection (EP) or ground-fault alarm (EA) can be selected. For fieldbus communications a communications module must be selected in addition.</p> <p>Add-on functions for circuit-breakers Type U (equipped with Digitrip 520M)</p>						
Ground fault protection With ground-fault protection instead of overload alarm.	24 DC	I ZMX16...-U... (Digitrip 520M)	<b>+IZMX-DTU-EP</b> 124018		1 off	24 V DC control voltage required
Ground alarm With ground-fault alarm instead of overload alarm.	24 DC	I ZMX16...-U... (Digitrip 520M)	<b>+IZMX-DTU-EA</b> 124019		1 off	
ARMS Function The ARMS (Arcflash Reduction Maintenance System™) function enhances personnel safety by reducing the tripping time through a short-circuit protection bypass in the event of an arcing fault.	24 DC	I ZMX16...-U... (Digitrip 520M)	<b>+IZMX-DTU-ARMS</b> 124020		1 off	
Zone selectivity Zone selectivity decreases the time delays in time selective coordination.	24 DC	I ZMX16...-U... (Digitrip 520M)	<b>+IZMX-DTU-ZSI</b> 124021		1 off	
<b>Communication modules</b>						
Communication module Modbus	–	I ZMX16...	<b>IZMX-MCAM</b> 122892		1 off	When retrofitting, four additional control circuit terminal blocks are required. → Page 18/19
Communication module PROFIBUS	–	I ZMX16...	<b>IZMX-PCAM</b> 122913		1 off	
<b>Test device</b> Hand-held tester for Digitrip Hand-held tester (100 - 240 V AC)	–	I ZMX16... I ZM26...	<b>I ZM-TEST-KIT</b> 124161		1 off	–

WWW.TM2A.PT info@tm2a.pt

WWW.TM2A.PT info@tm2a.pt



Rated operational current $I_n$ A	For use with	Part no. Article no.  Part no. suffix "+IZM..." Article no. for ordering with basic device	Price See price list	Std. pack	Notes
<b>Options and accessories for electronic releases</b>					
Rating plugs (Rate current modules), 3 pole, 4 pole The rated current can be reduced by changing the rating plug, for example, in order to adapt to changed conditions in the application. The rating plug's nominal value must be less than or equal to the basic device's rated current. The rating plug can be replaced on site without replacing the transformer.					
200	$I_u \leq 800$ A	<b>IZMX-RP16A-200</b> 124027		1 off	–
200	$I_u \leq 800$ A	<b>+IZMX-RP16-200</b> 124026			
250	$I_u \leq 800$ A	<b>IZMX-RP16A-250</b> 124029			
250	$I_u \leq 800$ A	<b>+IZMX-RP16-250</b> 124028			
300	$I_u \leq 800$ A	<b>IZMX-RP16A-300</b> 124031			
300	$I_u \leq 800$ A	<b>+IZMX-RP16-300</b> 124030			
400	$I_u \leq 800$ A	<b>IZMX-RP16A-400</b> 124033			
400	$1000 \text{ A} \leq I_u \leq 1250$ A	<b>IZMX-RP16B-400</b> 124034			
400	$I_u \leq 1250$ A	<b>+IZMX-RP16-400</b> 124032			
500	$I_u \leq 800$ A	<b>IZMX-RP16A-500</b> 124036			
500	$1000 \text{ A} \leq I_u \leq 1250$ A	<b>IZMX-RP16B-500</b> 124037			
500	$I_u \leq 1250$ A	<b>+IZMX-RP16-500</b> 124035			
630	$I_u \leq 800$ A	<b>IZMX-RP16A-630</b> 124039			
630	$1000 \text{ A} \leq I_u \leq 1250$ A	<b>IZMX-RP16B-630</b> 124040			
630	$800 \text{ A} \leq I_u \leq 1250$ A	<b>+IZMX-RP16-630</b> 124038			
800	$I_u \leq 800$ A	<b>IZMX-RP16A-800</b> 124042			
800	$1000 \text{ A} \leq I_u \leq 1250$ A	<b>IZMX-RP16B-800</b> 124043			
800	$I_u = 1600$ A	<b>IZMX-RP16C-800</b> 124051			
800	$1000 \text{ A} \leq I_u \leq 1600$ A	<b>+IZMX-RP16-800</b> 124041			
1000	$1000 \text{ A} \leq I_u \leq 1250$ A	<b>IZMX-RP16B-1000</b> 124131			
1000	$I_u = 1600$ A	<b>IZMX-RP16C-1000</b> 124156			
1000	$1250 \text{ A} \leq I_u \leq 1600$ A	<b>+IZMX-RP16-1000</b> 124091			
1250	$I_u \leq 1250$ A	<b>IZMX-RP16B-1250</b> 124158			
1250	$I_u = 1600$ A	<b>IZMX-RP16C-1250</b> 124159			
1250	$I_u = 1600$ A	<b>+IZMX-RP16-1250</b> 124157			
1600	$I_u = 1600$ A	<b>IZMX-RP16C-1600</b> 124160			
<b>Current sensor for neutral conductor</b>					
–	IZMX16...	<b>IZMX-CT16-N</b> 124188		1 off	An additional control circuit terminal block is required for retrofitting. → Page 18/19

WWW.TM2A.PT info@tm2a.pt

WWW.TM2A.PT info@tm2a.pt



HPL18019EN

I<sub>ZM</sub>X-THV..., I<sub>ZM</sub>X-SEC16-TB..., I<sub>ZM</sub>X-DEG16, I<sub>ZM</sub>X-DC16

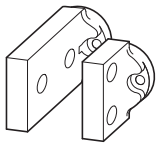
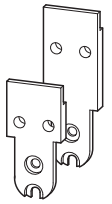
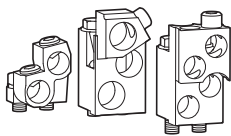
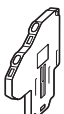
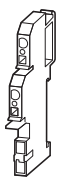
	Rated operational current I <sub>n</sub> A	Pole	For use with	Part no. Article no.	Price See price list	Std. pack
<b>Main terminal kits</b>						
Main terminals are not supplied as standard with the basic devices and cassettes. This universal adapter can be used both as horizontal and as vertical connector. Each set contains the connections for top and bottom. 3 pole = 6 off; 4 pole = 8 off						
	Rear universal connection for fixed/withdrawable mounting	800 - 1600	3	I <sub>ZM</sub> X16...3-W I <sub>N</sub> X16...3-W	<b>I<sub>ZM</sub>X-THV163</b> 124181	1 off
			4	I <sub>ZM</sub> X16...4-W I <sub>N</sub> X16...4-W	<b>I<sub>ZM</sub>X-THV164</b> 124177	
	Rear universal connection (long) for fixed/withdrawable mounting	800 - 1600	3	I <sub>ZM</sub> X16...3-W I <sub>N</sub> X16...3-W	<b>I<sub>ZM</sub>X-THVL163</b> 124233	
			4	I <sub>ZM</sub> X16...4-W I <sub>N</sub> X16...4-W	<b>I<sub>ZM</sub>X-THVL164</b> 124234	
	Front universal connection (long) for withdrawable mounting	800 - 1600	3	I <sub>ZM</sub> X16...3-W I <sub>N</sub> X16...3-W	<b>I<sub>ZM</sub>X-TFL163</b> 124183	
			4	I <sub>ZM</sub> X16...4-W I <sub>N</sub> X16...4-W	<b>I<sub>ZM</sub>X-TFL164</b> 124179	
<b>Tunnel terminals</b>						
For use only in combination with front universal connection I <sub>ZM</sub> X-TFL...						
	For connecting cables with 50-240 mm <sup>2</sup>	800 - 1600	-	I <sub>ZM</sub> X16...3- I <sub>N</sub> X16...3-	<b>I<sub>ZM</sub>X-TCA16-2</b> 124230	1 off
	For connecting cables with 95-185 mm <sup>2</sup>		-		<b>I<sub>ZM</sub>X-TCA16-3</b> 124231	
	For connecting cables with 120-240 mm <sup>2</sup>		-		<b>I<sub>ZM</sub>X-TCA16-4</b> 124232	
<b>General accessories</b>						
Control circuit terminal blocks for fixed mounting						
	Control circuit terminals, 8 blocks	-	-	I <sub>ZM</sub> X16...F I <sub>N</sub> X16...F	<b>I<sub>ZM</sub>X-SEC16-TB8-F</b> 124166	1 off
	Control circuit terminals, 20 blocks	-	-	I <sub>ZM</sub> X16...F I <sub>N</sub> X16...F	<b>I<sub>ZM</sub>X-SEC16-TB20-F</b> 124167	
	Control circuit terminals, 30 blocks	-	-	I <sub>ZM</sub> X16...F I <sub>N</sub> X16...F	<b>I<sub>ZM</sub>X-SEC16-TB30-F</b> 124168	
Control circuit terminal blocks for withdrawable blocks						
	Control circuit terminals, 8 blocks	-	-	I <sub>ZM</sub> X16...W I <sub>N</sub> X16...W	<b>I<sub>ZM</sub>X-SEC16-TB8-W</b> 124162	1 off
	Control circuit terminals, 20 blocks	-	-	I <sub>ZM</sub> X16...W I <sub>N</sub> X16...W	<b>I<sub>ZM</sub>X-SEC16-TB20-W</b> 124163	
	Control circuit terminals, 30 blocks	-	-	I <sub>ZM</sub> X16...W I <sub>N</sub> X16...W	<b>I<sub>ZM</sub>X-SEC16-TB30-W</b> 124165	
Protective cover, IP55						
	The protective cover allows a higher protection type.	-	-	I <sub>ZM</sub> X16... I <sub>N</sub> X16...	<b>I<sub>ZM</sub>X-DC 16</b> 124171	1 off
Blank cover for door cutout, IP41						
	Cover for a door cutout (reserved compartment)	-	-	I <sub>ZM</sub> X16... I <sub>N</sub> X16...	<b>I<sub>ZM</sub>X-BC16</b> 124172	1 off
Replacement coding, basic device to cassette						
	This is a spare part. The coding is supplied as standard with withdrawable switches.	-	-	I <sub>ZM</sub> X16...W I <sub>N</sub> X16...W	<b>I<sub>ZM</sub>X-CRB16</b> 124173	1 off
Replacement hand lever						
	This is a spare part. The hand lever is supplied as standard with withdrawable switches.	-	-	I <sub>ZM</sub> X16...W I <sub>N</sub> X16...W	<b>I<sub>ZM</sub>X-LT16</b> 124174	1 off
Spare door seal, IP41						
	This is a spare part. The door sealing frame is supplied as standard with fixed mounting.	-	-	I <sub>ZM</sub> X16...F I <sub>N</sub> X16...F	<b>I<sub>ZM</sub>X16-DEG-F</b> 124335	1 off
	This is a spare part. The door sealing frame is supplied as standard with withdrawable units.	-	-	I <sub>ZM</sub> X16...W I <sub>N</sub> X16...W	<b>I<sub>ZM</sub>X16-DEG-W</b> 124390	1 off

info@tm2a.pt

WWW.TM2A.PT

info@tm2a.pt

WWW.TM2A.PT



I<sup>2</sup>MX16

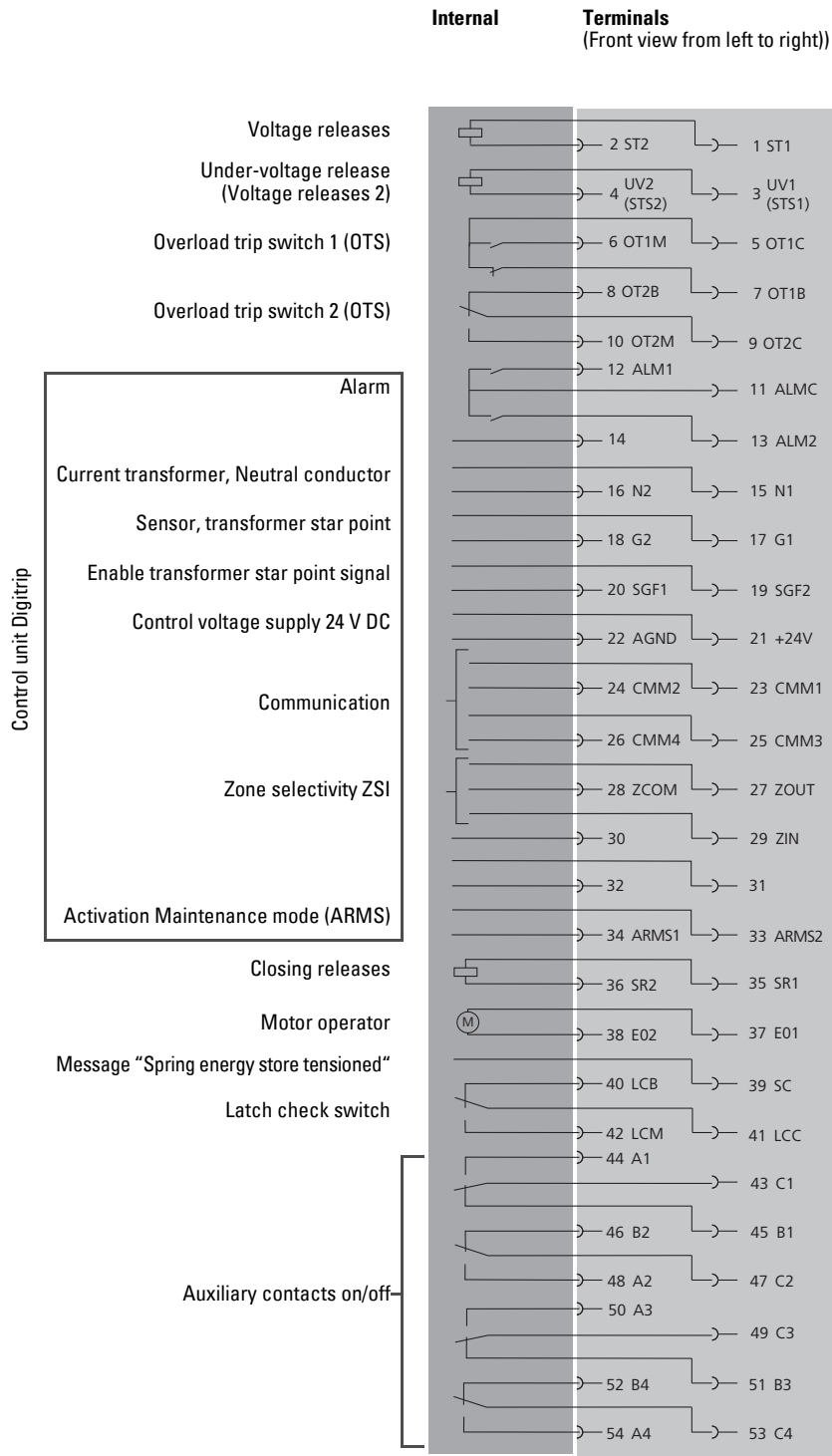

Control unit Digtrip

Alarm

Current transformer, Neutral conductor

Sensor, transformer star point

Enable transformer star point signal

Control voltage supply 24 V DC

Communication

Zone selectivity ZSI

Activation Maintenance mode (ARMS)

WWW.TM2A.PT info@tm2a.pt

WWW.TM2A.PT info@tm2a.pt



**IZMX16...A... Tripping characteristics for selective protection**

Overload protection (L) and non-delayed short-circuit protection (I)

L-protection: Adjustable

See Notes 1, 2, 3.

I-protection: Adjustable

See Notes 3, 4, 5, 6, 7.

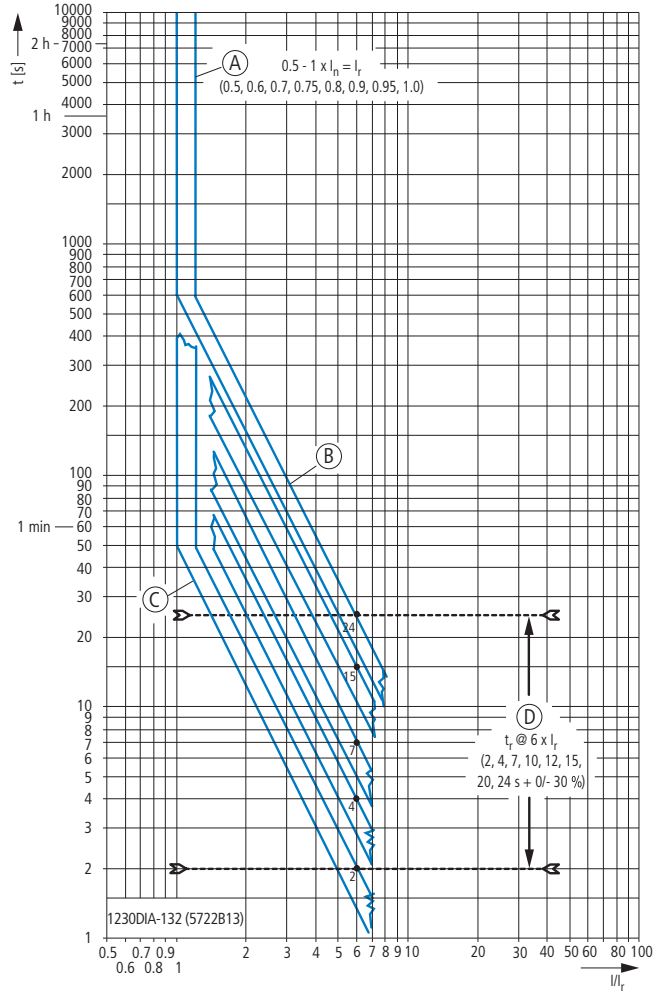

- A Set values for overload protection
- B Maximum total opening delay
- C Minimum total opening delay
- D Set values for long delay

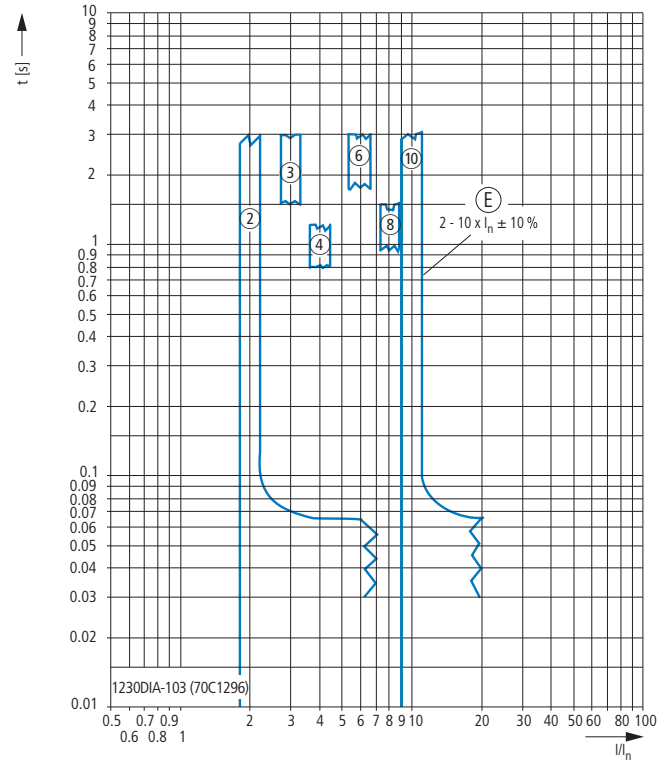

E Set values for non-delayed short-circuit protection

I-protection: For high short-circuit currents

See Notes 3, 4, 5, 6, 7.

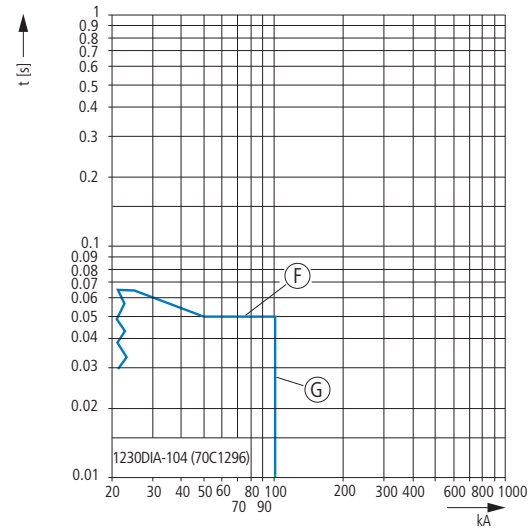

- F Set values for short-time delayed short-circuit protection with flat characteristic curve
- G The end of the characteristic curve is determined by the type of application and the switching capacity of the selected switch.



**IZMX16...V(U)...** Tripping characteristics for selectivity protection and universal protection

Overload protection (L) and short-time delayed short-circuit protection (S)

L-Protection: I<sup>2</sup>t-Characteristic curve and S-Protection: flat characteristic curve S-Protection: I<sup>2</sup>t-Characteristic curve

See Notes 1 to 7.

See Notes 1 to 7.

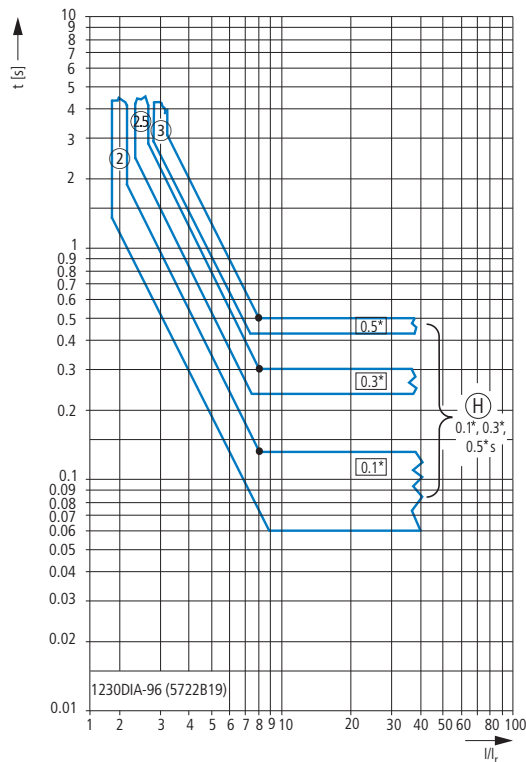
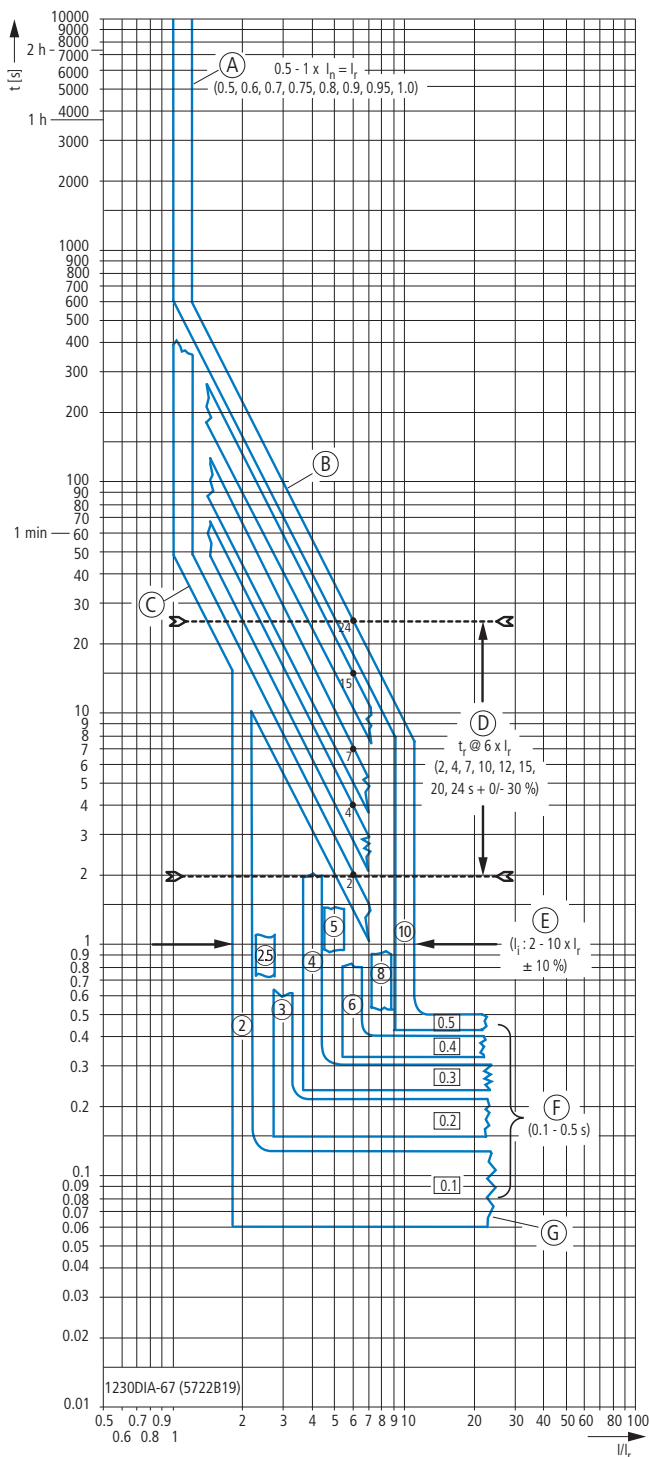

H The characteristic curve for the overload release can extend up to the M1 set value.

WWW.TM2A.PT info@tm2a.pt

WWW.TM2A.PT info@tm2a.pt

- A Set values for overload protection
- B Maximum total opening delay
- C Minimum total opening delay
- D Set values for long delay
- E Set value non-delayed short-circuit protection I<sub>r</sub>
- F Set values for short-time delayed short-circuit protection with flat characteristic curve
- G The end of the characteristic curve is determined by the type of application and the switching capacity of the selected switch.

**IZMX16...V(U)... Tripping characteristics for selectivity protection and universal protection**

Non-delayed short-circuit protection (I)

I-protection: Adjustable

See Notes 2, 6, 8, 9, 10, 11.

I-protection: For high short-circuit currents

See Notes 2, 6, 8, 9, 10, 11.

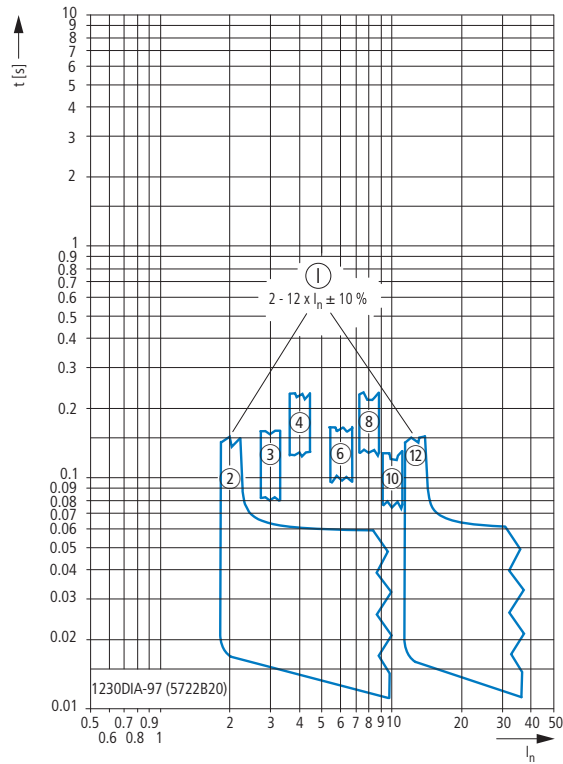

I Available set values for non-delayed short-circuit protection I<sub>sd</sub>

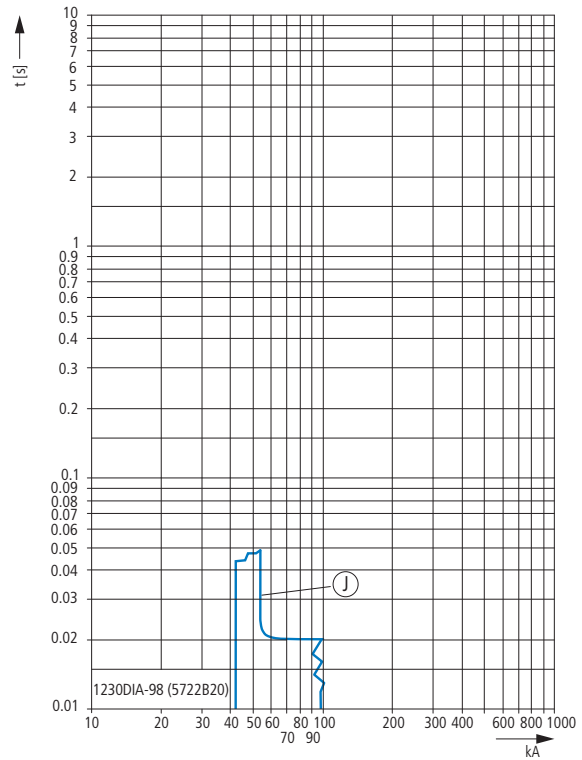

J Short-circuit release for very high currents

**IZMX16...V(U)... Option Ground fault protection +IZMX-DTV(U)-EP**

G: Ground fault protection, flat characteristic curve

See Notes 2, 6, 12, 13, 14, 15, 16.

G: Ground fault protection, I<sup>2</sup>t-Characteristic curve

See Notes 2, 6, 12, 13, 14, 15, 16.

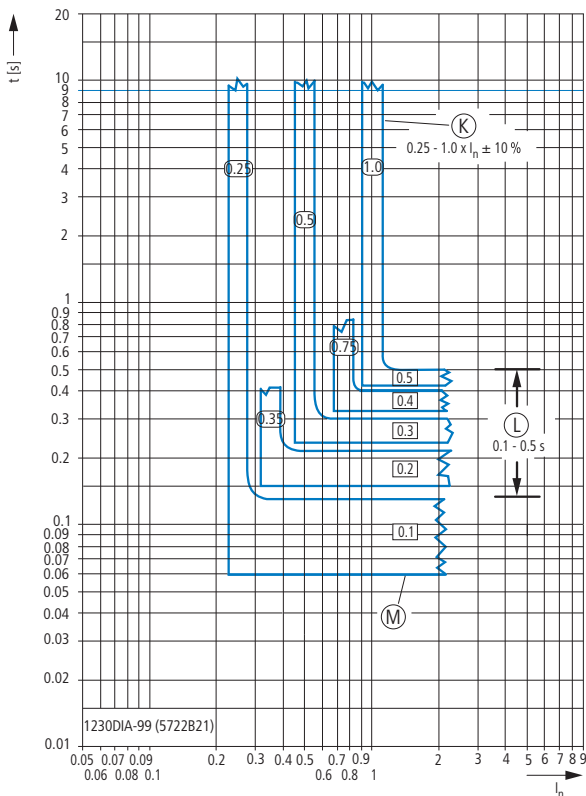

- K Set values for short-time delay at I<sup>2</sup>t characteristic curve
- L Set values for ground-fault protection
- M Set values for ground-fault protection delay at flat characteristic curve

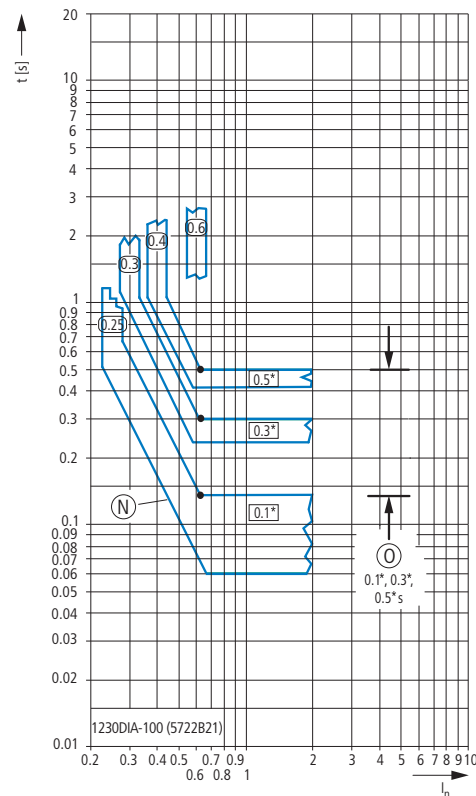

- N Flat characteristic curve for the delay time fault protection
- O I<sup>2</sup>t characteristic for ground-fault protection delay time

info@tm2a.pt

WWW.TM2A.PT

info@tm2a.pt

WWW.TM2A.PT





**IZMX16...U... Option Maintenance mode option +IZMX-DTU-ARMS**

ARMS-maintenance mode

See Notes 2, 6, 11, 17, 18, 19, 20.

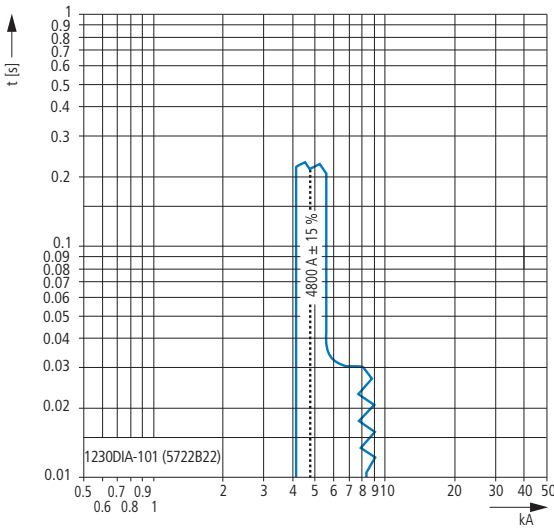

- A Set values for overload protection  $I_r$
- B Maximum total opening delay
- C Minimum total opening delay
- D Set value for long delay  $t_r$
- E Set value non-delayed short-circuit protection  $I_{sd}$
- F Set values for short-time delayed short-circuit protection with flat characteristic curve
- G The end of the characteristic curve is determined by the type of application and the switching capacity of the selected switch.
- H The characteristic curve for the overload release can extend up to the M1 set value.
- I Available set values for non-delayed short-circuit protection  $I_{sd}$
- J Short-circuit release for very high currents
- K Set values for short-time delay at  $I^2t$  characteristic curve
- L Set values for ground-fault protection
- M Set values for ground-fault protection delay at flat characteristic curve
- N Flat characteristic curve for the delay time fault protection
- O  $I^2t$  characteristic for ground-fault protection delay time

- 1 The trip unit has a thermal memory, which can shorten the value in the overload range. This function plays a role whenever a current is higher than the overload release's value and which is then isolated by a downstream circuit-breaker or the circuit-breaker itself. On a subsequent overload current the circuit-breaker will trip more quickly than normal. The reduced value is inversely proportional to the time expired since the last overload. After about five minutes the thermal memory is reset.
- 2 The end of the characteristic curve is determined by the type of application and the switching capacity of the selected switch.
- 3 The overload release trips at 110 %  $I_r$  with a tolerance of  $\pm 10$  % (indicated by the "Unit Status" LED). The short-time delayed short-circuit release  $I_{sd}$  is activated at a pick-up time of conventionally 100 % with a tolerance of  $\pm 10$  %.
- 4 When zone selectivity (ZSI) is activated in the short-time delayed short-circuit release and no blocking signal is applied, the minimum time value (0.10 s) applies irrespective of the short-time delay settings.
- 5 The upper lines of the  $I^2t$  characteristic curves are horizontal from a value of  $8 \times I_r$  (indicated by the points).
- 6 The listed overall switch-off times include the response times of the trip unit, the opening times of the switch and the time required to switch off the current.
- 7 The characteristic curves apply to applications in a temperature range from  $-20$  °C to  $+55$  °C. Temperatures over  $+85$  °C cause automatic tripping, indicated by an orange-colored LED. The circuit-breaker must be selected according to the temperature-dependent derating values from the table in the technical data.
- 8 The non-delayed short-circuit release is activated at a response value of conventionally 100 % with a tolerance of  $\pm 10$  %.
- 9 The non-delayed short-circuit release can be disabled by the user with an additional Off position.
- 10 All trip units feature an additional, permanently set non-delayed short-circuit release, which becomes active at a peak value of 90 kA. Tripping by this short-circuit release is indicated by a flashing INST LED. This protective function remains active when non-delayed tripping is set to Off.
- 11 The listed overall switch-off times are conservative and take into account the trip unit's maximum response times, the circuit-breaker's maximum opening delays and the longest current interruption times with regard to factors that contribute to worst-case conditions, such as maximum rated operational voltage, single-phase interruptions and minimum power factor. Fast breaking times are possible but depend on the system conditions and the circuit-breaker model.
- 12 The ground-fault release is activated at a response value of conventionally 100 % with a tolerance of  $\pm 10$  %.
- 13 Unless otherwise specified, the current value tolerances are  $\pm 10$  % of the values shown in the diagram.
- 14 In combination with ARMS function, ground-fault protection is limited to 1200 A.
- 15 When zone selectivity (ZSI) is activated in ground-fault protection and no blocking signal is applied, the minimum time value (flat characteristic curve) applies irrespective of the settings.
- 16 The upper lines of the  $I^2t$  characteristic curves are horizontal from a value of  $0.625 \times I_r$  (indicated by the points).
- 17 The maintenance mode function (ARMS) must be activated with a switch or through the communications terminals for these characteristic curves to apply. A blue LED indicates that the maintenance mode settings are active.
- 18 The shown switch-off times apply for connection to an additional auxiliary power supply.
- 19 Tripping by the ARMS Maintenance Mode Trip is indicated by the non-delayed short-circuit protection LED.
- 20 The tolerance is  $\pm 15$  %.

WWW.TM2A.PT info@tm2a.pt

WWW.TM2A.PT info@tm2a.pt



**I<sub>ZM</sub>X16**

**Rating plugs (Plus types)**

I <sub>n</sub> [A]	I <sub>u</sub> [A]	630	800	1000	1250	1600
200			+IZMX-RP16-200			
250			+IZMX-RP16-250			
300			+IZMX-RP16-300			
400			+IZMX-RP16-400			
500			+IZMX-RP16-500			
630	Standard		+IZMX-RP16-630			
800			Standard		+IZMX-RP16-800	
1000				Standard	+IZMX-RP16-1000	
1250					Standard	+IZMX-RP16-1250
1600						Standard

**Rating plugs (individual types)**

I <sub>n</sub> [A]	I <sub>u</sub> [A]	630	800	1000	1250	1600
200			IZMX-RP16A-200			
250			IZMX-RP16A-250			
300			IZMX-RP16A-300			
400			IZMX-RP16A-400		IZMX-RP16B-400	
500			IZMX-RP16A-500		IZMX-RP16B-500	
630			IZMX-RP16A-630		IZMX-RP16B-630	
800			IZMX-RP16A-800		IZMX-RP16B-800	IZMX-RP16C-800
1000					IZMX-RP16B-1000	IZMX-RP16C-1000
1250					IZMX-RP16B-1250	IZMX-RP16C-1250
1600						IZMX-RP16C-1600



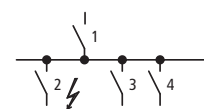

I<sub>n</sub>: Rated operational current
I<sub>u</sub>: Rated uninterrupted current
I<sub>cu</sub>: Rated short-circuit breaking capacity
I<sub>i</sub>: Set value non-delayed short-circuit releases

Selectivity 415 V AC

between circuit-breakers enables the separate disconnection of faulty system sections.

Selectivity exists between incoming circuit-breaker 1 and outgoing circuit-breaker 2 if, only outgoing breaker 2 trips at position 2 during a short-circuit.

System sections 3 and 4 remain operational.

Selection:

Provided that the short-circuit current does not exceed those values specified (I<sub>cc,rms</sub>).

These details represent the limits of selectivity.

Both circuit-breakers will switch off with higher short-circuit currents.

On IZM circuit-breakers with V, U, D releases, the delay time t<sub>sd</sub> must be at least 100 ms longer than the delay time of the next downstream levels (2, 3, 4).

Table with columns for Incoming circuit-breaker (1) and Outgoing circuit-breaker (2). It lists various models like NZMB(C)(N) and NZMC(N)(H) with their respective ratings and selectivity characteristics.

Notes B = Basic switching capacity, N = Normal switching capacity, H = High switching capacity, T = Total selectivity

Table with columns for IZMX16...-V and IZMX16...-U. It lists various models with their respective ratings and selectivity characteristics.



WWW.TM2A.PT info@tm2a.pt

WWW.TM2A.PT info@tm2a.pt



			IZMX16B...06...	IZMX16B...08...	IZMX16B...10...
<b>General</b>					
Standards			IEC/EN 60947	IEC/EN 60947	IEC/EN 60947
Ambient temperature	Storage	°C	-40 - +70 (devices with LCD display -20 - +70)		
	Operation (open)	°C	-25 - +70 (devices with LCD display -20 - +70)		
Mounting position					
Utilization category			B	B	B
Protection type			IP20, IP54 with protective cover		
Direction of incoming supply			Any	Any	Any
<b>Main contacts</b>					
Rated operational current = Rated uninterrupted current	$I_n = I_u$	A	630	800	1000
Rated uninterrupted current at 50 °C <sup>1)</sup>	$I_u$	A	599	760	950
Rated uninterrupted current at 60 °C <sup>1)</sup>	$I_u$	A	567	720	900
Rated uninterrupted current at 70 °C <sup>1)</sup>	$I_u$	A	504	640	800
Rated impulse withstand voltage	$U_{imp}$	V AC	8000	8000	8000
Rated operational voltage	$U_e$	V AC	690	690	690
Use in IT electrical power networks up to U = 440 V	$I_{IT}$	kA	21	21	21
Use in IT electrical power networks up to U = 690 V	$I_{IT}$	kA	-	-	-
Overvoltage category/pollution degree			III/3	III/3	III/3
Rated insulation voltage	$U_i$	V	1000	1000	1000
<b>Switching capacity</b>					
Rated short-circuitmaking capacity	Up to 440 V 50/60 Hz	$I_{cm}$	88	88	88
	Up to 690 V 50/60 Hz	$I_{cm}$	88	88	88
Rated short-time withstand current 50/60 Hz	t = 1 s	$I_{cw}$	42	42	42
	t = 3 s	$I_{cw}$	-	-	-
Rated short-circuit breaking capacity $I_{cn}$					
IEC/EN 60947 Operating sequence $I_{cu}$ 0-t-CO					
	Up to 240 V 50/60 Hz	$I_{cu}$	42	42	42
	Up to 440 V 50/60 Hz	$I_{cu}$	42	42	42
	Up to 690 V 50/60 Hz	$I_{cu}$	42	42	42
	Up to 1100 V 50/60 Hz	$I_{cu}$	-	-	-
IEC/EN 60947 Operating sequence $I_{cs}$ 0-t-CO-t-CO					
	Up to 240 V 50/60 Hz	$I_{cs}$	42	42	42
	Up to 440 V 50/60 Hz	$I_{cs}$	42	42	42
	Up to 690 V 50/60 Hz	$I_{cs}$	42	42	42
	Up to 1100 V 50/60 Hz	$I_{cs}$	-	-	-
<b>Switching times</b>					
Total opening delay		ms	20	20	20
Closing delay		ms	25	25	25
Closing delay electrical (via closing release)		ms	30	30	30
Opening delay electrical ( via shunt release / undervoltage release)		ms	25/50	25/50	25/50
Opening delay via trip electronics (non-delayed short-circuit release)		ms	25	25	25
Lifespan	Mechanical, without maintenance	Operations	12500	12500	12500
	Mechanical, with maintenance	Operations	20000	20000	20000
	Electrical, without maintenance	Operations	10000	10000	10000
	Electrical, with maintenance	Operations	10000	10000	10000
Maximum operating frequency		Operations/h	60	60	60
Heat dissipation at rated operational current $I_n$ 3-phase symmetric loading	Fixed	W	36	59	92
	Withdrawable	W	50	80	125
<b>Weight</b>					
Fixed	3 pole	kg	15	15	15
	4 pole	kg	20	20	20
Withdrawable	3 pole	kg	39	39	39
	4 pole	kg	47	47	47
Empty cassette	3 pole	kg	18	18	18
	4 pole	kg	21	21	21

**Notes** <sup>1)</sup> Permissible continuous current for circuit-breakers used at different temperatures within a switchgear assembly. The expected internal temperatures can be estimated according to the applicable IEC Standards.

IZMX16B...12...	IZMX16B...16...	IZMX16N...06...	IZMX16N...08...	IZMX16N...10...	IZMX16N...12...	IZMX16N...16...
IEC/EN 60947	IEC/EN 60947	IEC/EN 60947	IEC/EN 60947	IEC/EN 60947	IEC/EN 60947	IEC/EN 60947
-40 - +70 (devices with LCD display -20 - +70)						
-25 - +70 (devices with LCD display -20 - +70)						
B	B	B	B	B	B	B
IP20, IP54 with protective cover						
Any	Any	Any	Any	Any	Any	Any
1250	1600	630	800	1000	1250	1600
1188	1520	599	760	950	1188	1520
1125	1440	567	720	900	1125	1440
1000	1280	504	640	800	1000	1280
8000	8000	8000	8000	8000	8000	8000
690	690	690	690	690	690	690
21	21	21	21	21	21	21
-	-	-	-	-	-	-
III/3	III/3	III/3	III/3	III/3	III/3	III/3
1000	1000	1000	1000	1000	1000	1000
88	88	105	105	105	105	105
88	88	88	88	88	88	88
42	42	42	42	42	42	42
-	-	-	-	-	-	-
42	42	85	85	85	85	85
42	42	50	50	50	50	50
42	42	42	42	42	42	42
-	-	-	-	-	-	-
42	42	50	50	50	50	50
42	42	50	50	50	50	50
42	42	42	42	42	42	42
-	-	-	-	-	-	-
20	20	20	20	20	20	20
25	25	25	25	25	25	25
30	30	30	30	30	30	30
25/50	25/50	25/50	25/50	25/50	25/50	25/50
25	25	25	25	25	25	25
12500	12500	12500	12500	12500	12500	12500
20000	20000	20000	20000	20000	20000	20000
10000	10000	10000	10000	10000	10000	10000
10000	10000	10000	10000	10000	10000	10000
60	60	60	60	60	60	60
132	235	36	59	92	132	235
180	320	50	80	125	180	320
15	15	15	15	15	15	15
20	20	20	20	20	20	20
39	39	39	39	39	39	39
47	47	47	47	47	47	47
18	18	18	18	18	18	18
21	21	21	21	21	21	21

			IZMX16H...06...	IZMX16H...08...
<b>General</b>				
Standards			IEC/EN 60947	IEC/EN 60947
Ambient temperature	Storage	°C	-40 - +70 (devices with LCD display -20 - +70)	
	Operation (open)	°C	-25 - +70 (devices with LCD display -20 - +70)	
Mounting position				
Utilization category			B	B
Protection type			IP20, IP54 with protective cover	
Direction of incoming supply			Any	Any
<b>Main contacts</b>				
Rated operational current = Rated uninterrupted current	$I_n = I_u$	A	630	800
Rated uninterrupted current at 50 °C <sup>1)</sup>	$I_u$	A	599	760
Rated uninterrupted current at 60 °C <sup>1)</sup>	$I_u$	A	567	720
Rated uninterrupted current at 70 °C <sup>1)</sup>	$I_u$	A	504	640
Rated impulse withstand voltage	$U_{imp}$	V AC	8000	8000
Rated operational voltage	$U_e$	V AC	690	690
Use in IT electrical power networks up to U = 440 V	$I_{IT}$	kA	21	21
Use in IT electrical power networks up to U = 690 V	$I_{IT}$	kA	-	-
Overvoltage category/pollution degree			III/3	III/3
Rated insulation voltage	$U_i$	V	1000	1000
<b>Switching capacity</b>				
Rated short-circuit making capacity	Up to 440 V 50/60 Hz	$I_{cm}$	kA	137
	Up to 690 V 50/60 Hz	$I_{cm}$	kA	88
Rated short-time withstand current 50/60 Hz	t = 1 s	$I_{cw}$	kA	42
	t = 3 s	$I_{cw}$	kA	-
Rated short-circuit breaking capacity $I_{cn}$				
IEC/EN 60947 Operating sequence $I_{cu}$ 0-t-CO				
	Up to 240 V 50/60 Hz	$I_{cu}$	kA	85
	Up to 440 V 50/60 Hz	$I_{cu}$	kA	65
	Up to 690 V 50/60 Hz	$I_{cu}$	kA	42
	Up to 1100 V 50/60 Hz	$I_{cu}$	kA	-
IEC/EN 60947 Operating sequence $I_{cs}$ 0-t-CO-t-CO				
	Up to 240 V 50/60 Hz	$I_{cs}$	kA	65
	Up to 440 V 50/60 Hz	$I_{cs}$	kA	50
	Up to 690 V 50/60 Hz	$I_{cs}$	kA	42
	Up to 1100 V 50/60 Hz	$I_{cs}$	kA	-
<b>Switching times</b>				
Total opening delay		ms	20	20
Closing delay		ms	25	25
Closing delay electrical (via closing release)		ms	30	30
Opening delay electrical (via shunt release / undervoltage release)		ms	25/50	25/50
Opening delay via trip electronics (non-delayed short-circuit release)		ms	25	25
<b>Lifespan</b>				
Mechanical, without maintenance	Operations		12500	12500
Mechanical, with maintenance	Operations		20000	20000
Electrical, without maintenance	Operations		10000	10000
Electrical, with maintenance	Operations		10000	10000
Maximum operating frequency	Operations/h		60	60
Heat dissipation at rated operational current $I_n$ 3-phase symmetric loading				
Fixed		W	36	59
Withdrawable		W	50	80
<b>Weight</b>				
Fixed	3 pole	kg	15	15
	4 pole	kg	20	20
Withdrawable	3 pole	kg	39	39
	4 pole	kg	47	47
Empty cassette	3 pole	kg	18	18
	4 pole	kg	21	21

**Notes** <sup>1)</sup> Permissible continuous current for circuit-breakers used at different temperatures within a switchgear assembly. The expected internal temperatures can be estimated according to the applicable IEC Standards.

IZMX16H...10...	IZMX16H...12...	IZMX16H...16...
IEC/EN 60947		
-40 - +70 (devices with LCD display -20 - +70)		
-25 - +70 (devices with LCD display -20 - +70)		
		
B	B	B
IP20, IP54 with protective cover		
Any	Any	Any
1000	1250	1600
950	1188	1520
900	1125	1440
800	1000	1280
8000	8000	8000
690	690	690
21	21	21
-	-	-
III/3	III/3	III/3
1000	1000	1000
137	137	137
88	88	88
42	42	42
-	-	-
85	85	85
65	65	65
42	42	42
-	-	-
65	65	65
50	50	50
42	42	42
-	-	-
20	20	20
25	25	25
30	30	30
25/50	25/50	25/50
25	25	25
12500	12500	12500
20000	20000	20000
10000	10000	10000
10000	10000	10000
60	60	60
92	132	235
125	180	320
15	15	15
20	20	20
39	39	39
47	47	47
18	18	18
21	21	21



			INX16B...06...	INX16B...08...	INX16B...10...
<b>General</b>					
Standards			IEC/EN 60947	IEC/EN 60947	IEC/EN 60947
Ambient temperature					
Storage		°C	-40 - +70	-40 - +70	-40 - +70
Operation (open)		°C	-25 - +70 (devices with LCD display -20 - +70)		
Mounting position					
Utilization category			B	B	B
Protection type			IP20, IP54 with protective cover	IP20, IP54 with protective cover	IP20, IP54 with protective cover
Direction of incoming supply			Any	Any	Any
<b>Main contacts</b>					
Rated operational current = Rated uninterrupted current	$I_n = I_u$	A	630	800	1000
Rated uninterrupted current at 50 °C <sup>1)</sup>	$I_u$	A	599	760	950
Rated uninterrupted current at 60 °C <sup>1)</sup>	$I_u$	A	567	720	900
Rated uninterrupted current at 70 °C <sup>1)</sup>	$I_u$	A	504	640	800
Rated impulse withstand voltage	$U_{imp}$	V AC	8000	8000	8000
Rated operational voltage	$U_e$	V AC	690	690	690
Use in IT electrical power networks up to $U = 440$ V	$I_{IT}$	kA	21	21	21
Use in IT electrical power networks up to $U = 690$ V	$I_{IT}$	kA	-	-	-
Overvoltage category/pollution degree			III/3	III/3	III/3
Rated insulation voltage	$U_i$	V	1000	1000	1000
<b>Switching capacity</b>					
Rated short-circuit making capacity					
Up to 440 V 50/60 Hz	$I_{cm}$	kA	88	88	88
Up to 690 V 50/60 Hz	$I_{cm}$	kA	88	88	88
Rated short-time withstand current 50/60 Hz					
$t = 1$ s	$I_{cw}$	kA	42	42	42
$t = 3$ s	$I_{cw}$	kA	-	-	-
Switching times					
Total opening delay		ms	20	20	20
Closing delay		ms	25	25	25
Closing delay electrical (via closing release)		ms	30	30	30
Opening delay electrical ( via shunt release / undervoltage release)		ms	25/50	25/50	25/50
Lifespan					
Mechanical, without maintenance	Operations		12500	12500	12500
Mechanical, with maintenance	Operations		20000	20000	20000
Electrical, without maintenance	Operations		10000	10000	10000
Electrical, with maintenance	Operations		10000	10000	10000
Maximum operating frequency	Operations/h		60	60	60
Heat dissipation at rated operational current $I_n$ 3-phase symmetric loading					
Fixed		W	36	59	92
Withdrawable		W	50	80	125
<b>Weight</b>					
Fixed					
3 pole		kg	15	15	15
4 pole		kg	20	20	20
Withdrawable					
3 pole		kg	39	39	39
4 pole		kg	47	47	47
Empty cassette					
3 pole		kg	18	18	18
4 pole		kg	21	21	21

**Notes** <sup>1)</sup> Permissible continuous current for circuit-breakers used at different temperatures within a switchgear assembly. The expected internal temperatures can be estimated according to the applicable IEC Standards.

INX16B...12...	INX16B...16...
IEC/EN 60947	
-40 - +70	
-25 - +70 (devices with LCD display -20 - +70)	
B	
IP20, IP54 with protective cover	
Any	
1250	1600
1188	1520
1125	1440
1000	1280
8000	8000
690	690
21	21
-	-
III/3	III/3
1000	1000
88	
88	
42	
-	
20	
25	
30	
25/50	
12500	
20000	
10000	
10000	
60	
132	235
180	320
15	
20	
39	
47	
18	
21	

WWW.TM2A.PT info@tm2a.pt



WWW.TM2A.PT info@tm2a.pt

WWW.TM2A.PT info@tm2a.pt



			Auxiliary contacts IZMX-AS22	Overload trip IZMX-OTS	IZMX-LCS16(-SR)
<b>Rated breaking capacity</b>					
Inductive load					
250 V AC		A	10	10	10
125 V DC		A	0.5	0.5	0.5
250 V DC		A	0.25	0.25	0.25

			Voltage releases				Closing releases			
			IZMX-ST24DC IZMX-ST24DC	IZMX-ST48DC IZMX-ST48DC	IZMX-ST110AD IZMX-ST110AD	IZMX-ST230AD IZMX-ST230AD	IZMX-SR24DC	IZMX-SR48DC	IZMX-SR110AD	IZMX-SR230AD
<b>Rated control voltage</b>										
AC 50/60 Hz	U <sub>s</sub>	V	–	–	110 - 127	208 - 240	–	–	110 - 127	208 - 240
DC	U <sub>s</sub>	V	24	48	110 - 125	220 - 250	24	48	110 - 125	220 - 250
<b>Power consumption</b>										
AC		VA	–	–	(pick-up 450)	(pick-up 450)	–	–	(pick-up 450)	(pick-up 450)
DC		W	(pick-up 250)	(pick-up 250)	(pick-up 450)	(pick-up 450)	(pick-up 250)	(pick-up 250)	(pick-up 450)	(pick-up 450)
<b>Response time of the circuit-breaker with U<sub>s</sub></b>		ms	35	35	35	35	40	40	40	40
<b>Operating range</b>										
Drop-out voltage										
AC operated, 50/60 Hz	Drop-out	x U <sub>c</sub>	–	–	–	–	–	–	–	–
Pick-up voltage	pick-up	x U <sub>c</sub>	Acc. to IEC standard	Acc. to IEC standard	Acc. to IEC standard	Acc. to IEC standard	Acc. to IEC standard	Acc. to IEC standard	Acc. to IEC standard	Acc. to IEC standard

			Under-voltage releases			
			IZMX-UVR24DC	IZMX-UVR48DC	IZMX-UVR110AD	IZMX-UVR220AD
<b>Rated control voltage</b>						
AC 50/60 Hz	U <sub>s</sub>	V	–	–	110 - 127	208 - 240
DC	U <sub>s</sub>	V	24	48	110 - 125	220 - 250
<b>Power consumption</b>						
AC		VA	–	–	5 (pick-up 890)	5 (pick-up 910)
DC		W	5 (pick-up 500)	5 (pick-up 850)	5 (pick-up 890)	5 (pick-up 910)
<b>Response time of the circuit-breaker with U<sub>s</sub></b>		ms	50	50	50	50
<b>Operating range</b>						
Drop-out voltage						
AC operated, 50/60 Hz	Drop-out	x U <sub>c</sub>	Acc. to IEC standard	Acc. to IEC standard	Acc. to IEC standard	Acc. to IEC standard
Pick-up voltage	pick-up	x U <sub>c</sub>	Acc. to IEC standard	Acc. to IEC standard	Acc. to IEC standard	Acc. to IEC standard





**IZMX-M16...**

			Motor operator					
			IZMX-M16-24DC	IZMX-M16-48DC	IZMX-M16-110AC	IZMX-M16-110DC	IZMX-M16-230AC	IZMX-M16-220DC
<b>Rated control voltage</b>								
AC 50/60 Hz	$U_s$	V	–	–	110 - 127	–	220 - 240	–
DC	$U_s$	V	24	48	–	110 - 125	–	220 - 250
<b>Necessary time required for charging of the spring-operated stored energy mechanism at <math>1 \times U_s</math></b>		s	3	3	3	3	4	4
<b>Rated operational current</b>	$I_n$	A	5	3	2	1	1	1
<b>Starting current</b>		A	25	15	6	5	10	10
<b>Power consumption</b>								
AC 50/60 Hz		VA	–	–	280	280	280	280
DC		W	150	150	150	150	150	280

**Dimensions**

**INX16, IZMX16 fixed mounted**

INX16...F, IZMX16...F

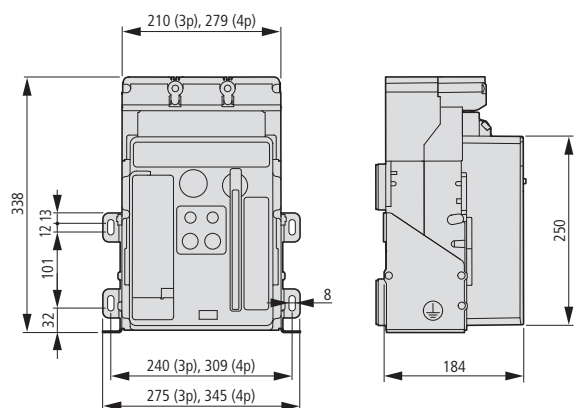

**INX16, IZMX16 withdrawable units**

INX16...W, IZMX16...W

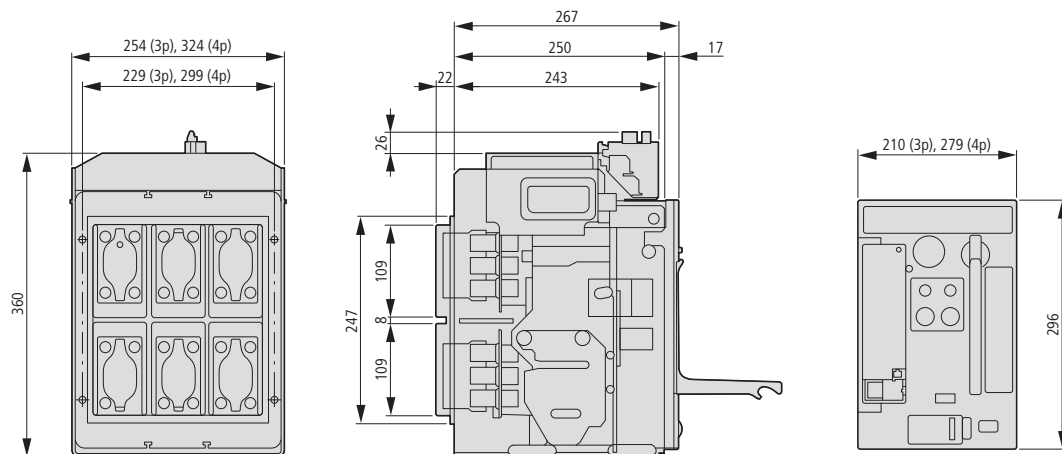

WWW.TM2A.PT info@tm2a.pt

WWW.TM2A.PT info@tm2a.pt



## IZM26

$I_{CU} = I_{CS}$ at $U_e = 440/690$ (1100) V AC $I_{CU}$ : Rated ultimate short-circuit breaking capacity at rated operational voltage $U_e$ $I_{CS}$ : rated service short-circuit breaking capacity at rated operational voltage $U_e$		Basic switching capacity (B)	Normal switching capacity (N)	High switching capacity (H)	(S)
Circuit-breaker	Rated operational current $I_n$ A	$I_{CU}/I_{CS}$ kA/kA	$I_{CU}/I_{CS}$ kA/kA	$I_{CU}/I_{CS}$ kA/kA	$I_{CU}/I_{CS}$ kA/kA
IZM20	800 - 1600	50/50	65/65	-	-
IZM20	2000	50/50	65/65	-	-
IZM32	800 - 1600	65/65	85/85	100/85	-
IZM32	2000 - 3200	65/65	85/85	100/85	-
IZM40	4000	-	85/65	100/65	-
IZM63	4000 - 6300	-	85/85	100/100	-
IZM32S	3200	-	-	-	25

$I_{CU} = I_{CS}$ at $U_e = 440/690$ (1100) V AC $I_{CW}$ at $t = 1$ s/ $t = 3$ s $I_{CW}$ : Rated short-time withstand current		Basic switching capacity (B)	Normal switching capacity (N)	High switching capacity (H)
Circuit-breaker	Rated operational current $I_n$ A	$I_{CW}/I_{CW}$ kA/kA	$I_{CW}/I_{CW}$ kA/kA	$I_{CW}/I_{CW}$ kA/kA
IZM20	800 - 1600	50/-	65/40	-
IZM20	2000	50/30	65/40	-
IZM32	800 - 1600	65/-	85/65	85/65
IZM32	2000 - 3200	65/50	85/65	85/65
IZM40	4000	-	85/65	100/65
IZM63	4000 - 6300	-	85/65	100/65



**IN26**

<b><math>I_{cm}</math> at <math>U_e = 440/690</math> V AC</b> $I_{cm}$ : Rated short-circuit making capacity (Peak value) at rated operational voltage $U_e$		<b>Basic switching capacity (B)</b>	<b>Normal switching capacity (N)</b>	<b>High switching capacity (H)</b>	<b>(S)</b>
		440/690 V AC	440/690 V AC	440/690 V AC	1100 V AC
<b>Switch-disconnector</b>	Rated operational current $I_n$ A	$I_{cm}$ kA	$I_{cm}$ kA	$I_{cm}$ kA	$I_{cm}$ kA
<b>IN20</b>	800 - 1600	105	143	-	-
<b>IN20</b>	2000	105	143	-	-
<b>IN32</b>	800 - 1600	143	187	-	-
<b>IN32</b>	2000 - 3200	143	187	-	-
<b>IN40</b>	4000	-	187	220	-
<b>IN63</b>	4000 - 6300	-	187	220	-
<b>IN32S</b>	3200	-	-	-	52

<b><math>I_{cm}</math> at <math>U_e = 440/690</math> V AC</b> $I_{cw}$ at $t = 1$ s/ $t = 3$ s $I_{cw}$ : Rated short-time withstand current		<b>Basic switching capacity (B)</b>	<b>Normal switching capacity (N)</b>	<b>High switching capacity (H)</b>
		$t = 1$ s/ $t = 3$ s	$t = 1$ s/ $t = 3$ s	$t = 1$ s/ $t = 3$ s
<b>Switch-disconnector</b>	Rated operational current $I_n$ A	$I_{cw}/I_{cw}$ kA/kA	$I_{cw}/I_{cw}$ kA/kA	$I_{cw}/I_{cw}$ kA/kA
<b>IN20</b>	800 - 1600	50/-	65/40	-
<b>IN20</b>	2000	50/30	65/40	-
<b>IN32</b>	800 - 1600	65/-	85/65	-
<b>IN32</b>	2000 - 3200	65/50	85/65	-
<b>IN40</b>	4000	-	85/65	100/65
<b>IN63</b>	4000 - 6300	-	85/65	100/65

WWW.TM2A.PT info@tm2a.pt

WWW.TM2A.PT info@tm2a.pt

WWW.TM2A.PT info@tm2a.pt

WWW.TM2A.PT info@tm2a.pt



I<sub>ZM</sub>26 ...-A...

System protection  
DTA  
Digitrip 520 LI



I<sub>ZM</sub>26 ...-V...

Selectivity protection  
DTV  
Digitrip 520 LSI(G)



I<sub>ZM</sub>26 ...-U...

Universal protection  
DTU  
Digitrip 520MC LSI(G)



I<sub>ZM</sub>26 ...-P...

Universal protection with  
power measurement  
DTP  
Digitrip 1150i LSI(G)



	I <sub>ZM</sub> 26 ...-A...	I <sub>ZM</sub> 26 ...-V...	I <sub>ZM</sub> 26 ...-U...	I <sub>ZM</sub> 26 ...-P...
Current range	200 A – 3200 A	200 A – 6300 A	200 A – 6300 A	200 A – 6300 A
RMS value monitoring	●	●	●	●
<b>Protective functions</b>				
General				
Ordering options	LI	LSI, LSIG	LSI, LSIG, LSIA	LSI, LSIG, LSIA
Rating plug (I <sub>n</sub> )	●	●	●	●
Overtemperature trip	●	●	●	●
Overload protection	<b>L</b>			
Overload trip	(0.4 - 1.0) x I <sub>n</sub>	(0.4 - 1.0) x I <sub>n</sub>	(0.4 - 1.0) x I <sub>n</sub>	(0.4 - 1.0) x I <sub>n</sub>
Long delay time I <sup>2</sup> t at 6 x I <sub>r</sub>	2 - 24 s	2 - 24 s	2 - 24 s	2 - 24 s
Long delay time I <sup>4</sup> t	–	–	–	1 - 5 s
Thermal memory	●	●	●	●
Overload alarm signal	–	–	○ <sup>1)</sup>	○ <sup>1)</sup> : (0.5 - 1.0) x I <sub>r</sub>
Short-time delayed short-circuit protection	<b>S</b>			
Short delay pickup	–	(2 - 10) x I <sub>r</sub> and M1 <sup>2)</sup>	(2 - 10) x I <sub>r</sub> and M1 <sup>2)</sup>	(2 - 10) x I <sub>r</sub> and M1 <sup>2)</sup>
Short delay time I <sup>2</sup> t at 8 x I <sub>r</sub>	–	100 - 500 ms	100 - 500 ms	100 - 500 ms
Short delay time, flat characteristic curve	–	100 - 500 ms	100 - 500 ms	100 - 500 ms
Zone selectivity ZSI <sup>1)</sup>	–	○	○	○
Non-delayed short-circuit protection	<b>I</b>			
Non-delayed short-circuit protection	(2 - 10) x I <sub>n</sub>	(2 - 10) x I <sub>n</sub> and M1 <sup>2)</sup>	(2 - 10) x I <sub>n</sub> and M1 <sup>2)</sup>	(2 - 10) x I <sub>n</sub> and M1 <sup>2)</sup>
Switch-off function	–	●	●	●
Closing releases MCR	●	●	●	●
Ground operational fault protection	<b>G</b>			
Ground/fault alarm	–	–	○ <sup>1)</sup>	○ <sup>1)</sup>
Ground fault protection release	–	(0.25 - 10) x I <sub>n</sub>	(0.25 - 10) x I <sub>n</sub> <sup>3)</sup>	(0.25 - 10) x I <sub>n</sub> <sup>3)</sup>
Short delay time I <sup>2</sup> t at 0.625 x I <sub>n</sub>	–	100 - 500 ms	100 - 500 ms	100 - 500 ms
Short delay time, curve	–	100 - 500 ms	100 - 500 ms	100 - 500 ms
Zone selectivity ZSI <sup>1)</sup>	–	○	○	○
Thermal memory	–	●	●	●
Neutral conductor-conductor protection	<b>N</b>			
Neutral conductor-conductor protection	●	Only for type LSI	Only for type LSI	Only for type LSI

Notes

I<sub>n</sub> = rating plug (rated current module) = rated operational current current transformer

I<sub>r</sub> = Set value overload trip (= Rated operational current of system)

<sup>1)</sup> Requires an external 24 V DC control voltage supply.

<sup>2)</sup> Additionally available M1 set values:

**I<sub>ZM</sub>20**

M1 = 14 x I<sub>n</sub> for rated operational currents von 200 A to 1250 A

M1 = 12 x I<sub>n</sub> for rated operational currents from 1600 A to 2000 A

**I<sub>ZM</sub>32**

M1 = 14 x I<sub>n</sub> for rated operational currents von 200 A to 1250 A

M1 = 12 x I<sub>n</sub> for rated operational current from 1600 A to 2500 A

M1 = 10 x I<sub>n</sub> for rated operational currents from 3200 A

**I<sub>ZM</sub>40**

M1 = 12 x I<sub>n</sub> for rated operational currents from 4000 A

**I<sub>ZM</sub>63**

M1 = 14 x I<sub>n</sub> for rated operational currents from 2000 A 2500 A

M1 = 12 x I<sub>n</sub> for rated operational currents von 3200 A 5000 A

M1 = 10 x I<sub>n</sub> for rated operational currents from 6300 A

<sup>3)</sup> In combination with ARMS function limited to 1200 A.

● Standard

○ Optional

**IZM26 ...-A...**

System protection  
DTA  
Digitrip 520 LI



**IZM26 ...-V...**

Selectivity protection  
DTV  
Digitrip 520 LSI(G)



**IZM26 ...-U...**

Universal protection  
DTU  
Digitrip 520MC LSI(G)



**IZM26 ...-P...**

Universal protection with  
power measuring  
DTP  
Digitrip 1150i LSI(G)



	IZM26 ...-A...	IZM26 ...-V...	IZM26 ...-U...	IZM26 ...-P...
<b>System diagnostics</b>				
Cause of trip LEDs	●	●	●	●
Current at trip point	—	—	● <sup>1)</sup>	● <sup>1)</sup>
Remote signaling contacts	<b>A</b> —	—	● <sup>1)</sup>	● <sup>1)</sup>
Programmable signal contacts	<b>A</b> —	—	—	● <sup>1)</sup>
<b>System monitor</b>				
Digital display	—	—	4-digit LED	24-digit LED
Current display (%)	—	—	●	●
Phase voltage (%)	—	—	—	●
Power and energy (%)	—	—	—	●
Apparent power kVA reference and delivery	—	—	—	●
Reactive power kVAR	—	—	—	●
Power factor	—	—	—	●
Crest factor	—	—	—	●
Power quality, harmonics	—	—	—	●
THD factor (%)	—	—	—	●
<b>Fieldbus communication</b>	—	—	Modbus, PROFIBUS	Modbus, PROFIBUS
<b>Additional functions</b>				
Trip history (3 events)	—	—	—	●
Electronic operations counter	—	—	—	●
Test possibility <sup>2)</sup>	Hand held test unit	Hand held test unit	Hand held test unit	Hand held test unit and integrated function
Maintenance mode ARMS	—	—	○ <sup>1)</sup>	○ <sup>1)</sup>
Curve-form plotting	—	—	—	●

**Notes**

$I_n$  = rating plug (rate current module) = rated operational current current transformer

$I_r$  = Set value overload trip (= rated operational current of system)

<sup>1)</sup> Requires an external 24 V DC control voltage supply.

<sup>2)</sup> Hand-held tester for simulating secondary current

● Standard  
○ Optional



System overview

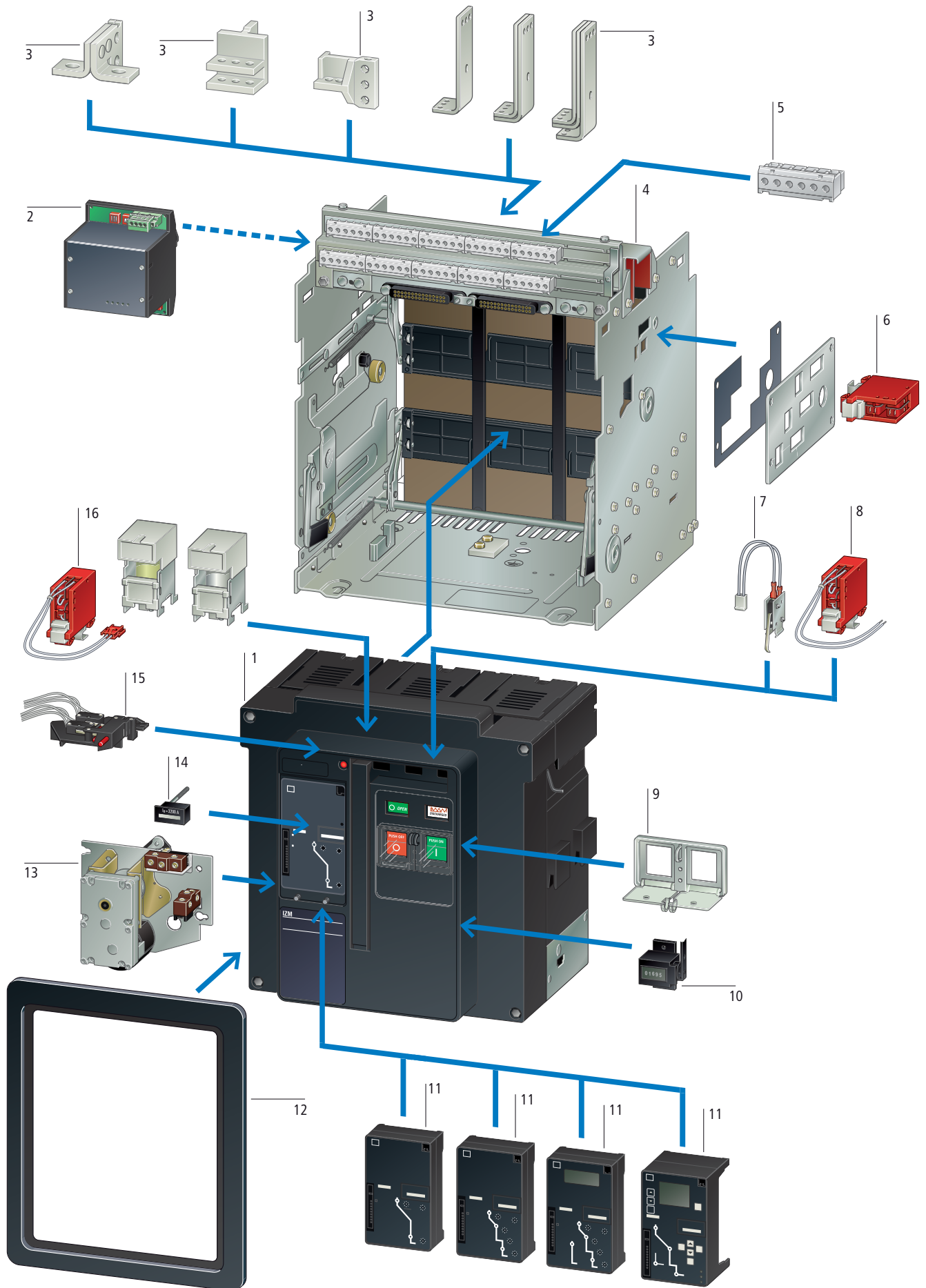

WWW.TM2A.PT info@tm2a.pt

WWW.TM2A.PT info@tm2a.pt

<b>IzM circuit-breakers</b>	1
→ Page 18/49	
<b>PROFIBUS and Modbus communication interfaces</b>	2
→ Page 18/75	
<b>Main terminal kits</b>	3
Vertical connections 3 and 4 pole	
Front connections 3 and 4 pole	
→ Page 18/79	
<b>Cassettes for withdrawable units</b>	4
Cassettes 2000 A to 6300 A	
→ Page 18/66	
<b>Control circuit terminal units</b>	5
Either 2 or 15 units	
→ Page 18/80	
<b>Position signalling switch for withdrawable units</b>	6
→ Page 18/68	

<b>Latch check switch</b>	7
→ Page 18/71	
<b>Auxiliary contacts</b>	8
Signalling switch ON-OFF, 2 C	
→ Page 18/71	
<b>Locking cover of ON/OFF buttons</b>	9
→ Page 18/72	
<b>Switching operations counters</b>	10
→ Page 18/68	
<b>Trip units</b>	11
Type A circuit-breakers	
Type V circuit-breakers	
Type U circuit-breakers	
Circuit-breakers P-Part no.	
→ Page 18/74	

<b>Door escutcheon</b>	12
→ Page 18/80	
<b>Motor operator</b>	13
Automatic charging of the spring-operated stored energy mechanism	
→ Page 18/68	
<b>Rating plug sensor and current transformer</b>	14
→ Page 18/76	
<b>Overload trip switch</b>	15
Overcurrent trip (OTS), 2 C	
→ Page 18/71	
<b>Voltage releases</b>	16
→ Page 18/69	
<b>Closing releases</b>	16
→ Page 18/69	
<b>Under voltage releases</b>	16
→ Page 18/70	

**Key to type references**

IzM	20	B	3	-	A	08	W
IN	32	N	4		V	10	F
	40	H			U	12	
	63	S			P	16	
						20	
						25	
						32	
						40	
						50	
						63	

**IzM, IN = Product family**

**Frame size**

- 20: Narrow 800 - 2000 A
- 32: Standard 800 - 3200 A
- 40: Double narrow 4000 A
- 63: Double wide 4000 - 6300 A

**Switching capacity**

- B = Basic
- N = Normal
- H = High
- S = Special type for 1100 V (only for size 32, 3200 A)

**Number of poles**

- 3: 3 pole
- 4: 4 pole

**Trip type**

- A= System protection = Digitrip 520 LI
- V= Selective protection = Digitrip 520 LSI(G)
- U= Universal protection = Digitrip 520MC LSI(G)
- P= Universal protection with power measurement = Digitrip 1150i+ LSI(G)

**Rated operational current**

- 08: 800 A
- 10: 1000 A
- 12: 1250 A
- 16: 1600 A
- 20: 2000 A
- 25: 2500 A
- 32: 3200 A
- 40: 4000 A
- 50: 5000 A
- 63: 6300 A

**Model**

- W = Withdrawable
- F = Fixed





### IZM26: Robust safety

Eaton's IZM26 circuit-breakers offer a proven and complete range of air circuit-breakers up to 6300 A. Four sizes enable the ideal circuit-breaker to be selected economically for any project. In this way, only the module width increases with the required rated operational current, enabling the most compact and economical size to be selected.

The particularly rugged circuit-breakers are already in use 100,000 times in harsh industrial environments worldwide. Large material thicknesses and a high short-time withstand current are its characteristic features.

### Applications

The circuit-breakers can be used in four main application areas depending on the type of equipment to be protected:

- System protection,
- Motor protection,
- Transformer protection,
- Generator protection.

These key applications make different demands on the switches, which are met with a range of trip units.

### Switches with closing release

They are particularly suitable for synchronization tasks.

### Coupler switches

Beside the IZM26 circuit-breakers, IN26 switch-disconnectors are available. These are used, for example, as coupler switches between different power supplies.

### Modular design

Because components are installed from the front, retrofitting accessories is especially quick and easy. This allows flexible response to changing requirements within the system.

### Standard scope of delivery as usual

- With the new IZM26, you also select a basic device that is already fitted with an electronic release and horizontal terminal adapters.
- The standard mounting is on a horizontal mounting plate or on horizontal traverses in the switching cabinet.
- With four-pole devices, the neutral conductor is arranged on the left (front view).
- The neutral conductor can be loaded 100% like the phase conductors.
- The circuit-breakers are provided with a standard mechanical reclosing lockout. After an overload trip, the fault is usually examined first of all. After the fault is identified and rectified, the mechanical reclosing lockout is reset by pressing the red mechanical trip indicator on the front of the circuit-breaker.
- An "Automatic Reset" can be ordered as an option. This enables the circuit-breaker to be restored to operation immediately at any time after the spring-operated stored energy mechanism is retensioned. In these applications compulsory fault analysis is intentionally avoided.
- The number of control cable terminals depends on the accessories fitted.

- If a cassette is ordered without the basic device, this is already fitted with the maximum number of control cable terminals.
- The standard consists of 2 NO contacts and 2 NC contacts for ON/OFF status indication.
- A coding mechanism between the basic device and the cassette prevents impermissible combinations ("Rejection Interlock").

### Expansion of Standard equipment supplied for IZM26

Some order types from the past can no longer be found since the following options are now already part of the standard scope of delivery:

- The door escutcheon is now always included in the scope of delivery. With withdrawable designs this is supplied with the cassette (with-drawable unit).
- On withdrawable units the circuit-breaker can be pulled out to inspect the arc chutes. With fixed units, it is recommended that sufficient space is provided above the circuit-breaker to enable inspection. An additional cover is not required.
- All basic devices that are provided with universal protection (with Digitrip 520M...), now feature a display.
- On each circuit-breaker the integrated Digitrip electronic release is factory fitted with a sealable protective cover.
- If a motor operator is ordered, the "Spring-operated stored energy mechanism tensioned" indicator switch is automatically provided.



## Other benefits of the IZM26

- There are still four main variants of overcurrent release units. Only the fourth variant was renamed and is now "P" (as in Power Measurement) instead of "D" (as in Digital trip). On each P circuit-breaker (Digitrip 1150) the power measurement is already an integral part of the electronic release.
- The voltage tap-off for power measurement is integrated in the device so that an additional external voltage transformer is unnecessary. This solution saves costs, space and installation effort.
- Certain applications require the use of an interface to the external control voltage supply (see below). A new feature is that the electronic release can be prepared for an external control voltage supply of 120 V AC or 240 V AC (order option).
- A switching operations counter can now be used thanks to the separate mounting position, also independently of a motor operator.
- Withdrawable unit operation: The unit is actuated with a hand crank supplied. This is now possible also with a standard tool (square drive socket 3/8").
- Four sizes are available to ensure the optimum device for any application. As before, the entire rated operational current range from 800 A to 6300 A can be covered with two sizes.
- Sizes IZM40 and IZM63 are produced in simple terms by doubling sizes IZM20 and IZM32. This consequently provides on the IZM40 and IZM63 two terminals for each phase on the incoming side and on the outgoing side. This facilitates the thermal design of the switchboard and in some switchboard systems simplifies production and reduces the number of busbar adapter variants.
- The phase sequence for the IZM40 and IZM63 is as follows: (NN)AABBCC.
- The IZM for 6300 A is now offered with horizontal connection as standard, thus considerably simplifying the busbar connection for most switchboard systems.

## External control voltage supply

- The standard protection functions of the IZM26 operate generally independently of an external control voltage supply. The power supply of the electronics unit, for example for overload and short-circuit protection, is implemented via the current transformers integrated in the circuit-breaker.
- The universal release unit with display can be fed with a 24 V DC/48 V DC supply or a 120 V AC or 240 V AC supply if required so that the display function can also be used without a load. An external power supply is needed if communication functions are required.
- The P release unit should always be operated with an external power supply as it is normally selected due to its extensive control voltage dependent functions.

## Communication capability

The communication-capability of the IZM26 circuit-breakers enable them to open up new possibilities in power distribution. They can thus provide and transmit all important operational information. This increases system transparency and shortens the response times to states such as overcurrent, phase asymmetry and overvoltage.

A rapid intervention in a process can, for example, prevent downtimes and help to schedule maintenance activities and therefore boost plant availability.

A Modbus interface is offered as an alternative in addition to the Profibus interface.

## Greater safety for maintenance personnel with ARMS™

If the IZM26 is fitted with the newly patented ARMS system (Arcflash Reduction Maintenance System™), a non-delayed immediate disconnection is ensured in the event of an arc fault. This disconnection is even faster than that of a non-delayed short-circuit release.

This function can be activated directly on the circuit-breaker or via an external switch, such as when maintenance personnel enter a hazardous area. Other components from the ARCON protective system, in conjunction with the IZM26 enable arc fault protection in stages. ARCON on the Internet: [www.moeller.net/arcon](http://www.moeller.net/arcon)

## Selection criteria for IZM26 circuit-breakers

Fundamental criteria for the selection of circuit-breakers:

- Max short-circuit current  $I_{k\max}$  at the circuit-breaker's point of installation: this value determines the short-circuit breaking capacity or the short-circuit current carrying capacity of the circuit-breaker. It is compared to the  $I_{cu}$ ,  $I_{cs}$  and  $I_{cw}$  values of the circuit-breaker and determines essentially its size (see Technical data).
- Rated operational current  $I_n$  which should flow through the respective branch circuit: This value must not be greater than the maximum switch rated operational current of the circuit-breaker. The rated operational current can be adjusted down using additional rated operational current modules.
- Ambient temperature of the circuit-breaker: This is generally the internal temperature in the control panel. Observe the derating values with increased ambient temperature (see Technical data).
- Circuit-breaker type: fixed mounted or withdrawable units, 3 or 4 pole.
- Minimum short-circuit current, which flows through the switching device: The release must recognize this value as a short-circuit and may react with a trip.
- Protection functions of the circuit-breaker: This is determined by the selection of the respective overcurrent release.

## Documentation

Operating manual  
AWB1230-1605de (deutsch)  
AWB1230-1605en (english)

## CurveSelect characteristics program

Display tripping characteristics according to user settings and assess their interaction effectively:  
[www.moeller.net/de/support](http://www.moeller.net/de/support)



**Components for IZM26 communication**

The IZM26 series devices can be connected to a PROFIBUS-DP or Modbus RTU field bus. Interfaces IZM-PMINT and IZM-MMINT are compact devices for mounting on top-hat rails, i.e. independently of the switch. They output all information available in the trip unit to the fieldbus, including switch status, current, voltage, power, and energy, as well as diagnostic information such as overcurrent, phase asymmetry and overvoltage. The fieldbus also facilitates actuation of the motor operator and therefore its remote operation.

**Requirements**

The communications modules can be used in combination with IZMX26...-U or IZMX26...-P... circuit-breakers.

**PROFIBUS-DP configuration**

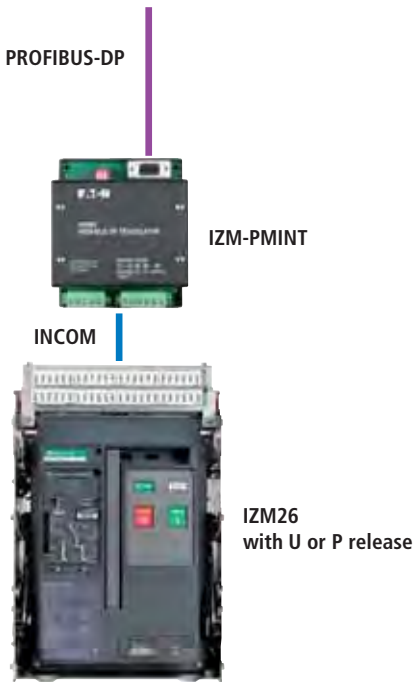

Communications module IZM-PMINT has a 9-pin D-Sub socket for connection to PROFIBUS. The module works as a slave on PROFIBUS-DP; the data is defined through a standardized device master data file, which permits smooth integration of the IZM in a DP line.

**PROFIBUS**

- On the PROFIBUS-DP side the module supports automatic baud rate detection; the PROFIBUS-DP bus address is set through the trip unit's display. The maximum cable length is 2.4 km.
- To operate the IZM-PMINT, a supply voltage of 24 V DC or 240 V AC is required.

**INCOM**

- The data connection to the circuit-breaker is implemented through a serial INCOM data connection. A shielded, twisted-pair data cable (recommended are Belden 9463 or 3073F) can be used.
- The INCOM bus must be terminated with a 100 Ω terminating resistor, connected between the two cable strands at the circuit-breaker end.
- The maximum cable length is 3 km.

**Data access via PROFIBUS-DP**

The data on PROFIBUS-DP are offered according to the profile for low-voltage switchgear (LVSG) of PROFIBUS International (PROFIBUS and PROFINET User Group). Five different data structures with varying numbers of parameters are available through the device master data file. This allows a data filter to be easily implemented, which simplifies integration of the IZM data into the control system.

**Modbus configuration**

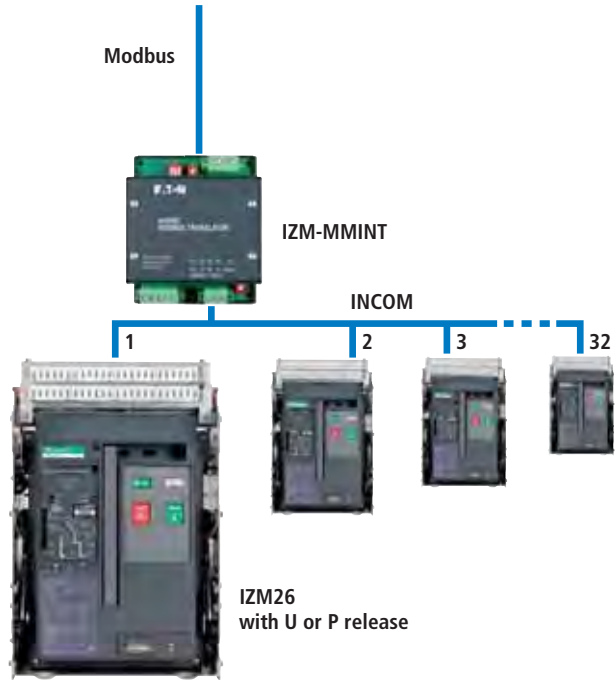

Communications module IZM-MMINT has a plug-in screw terminal for connection to Modbus. The module operates as a Modbus slave. The interface to the circuit-breaker can be operated as a bus, so that up to 32 IZM26 units can be connected to an IZM-MMINT. This makes the use of the IZM with the Modbus architecture specially efficient.

**Modbus**

- The baud rate for Modbus communications is selectable with coding switches on the IZM-MMINT; the bus address (up to 247) is set through the display of the trip unit. The maximum cable length is 1.2 km.
- The Modbus must be terminated with a 120 Ω terminating resistor. If the IZM-MMINT is the last device in the network, a built-in terminating resistor can be activated there with a coding switch.
- To operate the IZM-MMINT, a supply voltage of 24 V DC or 240 V AC is required.

**INCOM**

- The data connection to the circuit-breaker is implemented through a serial INCOM bus connection. A shielded, twisted-pair data cable (recommended are Belden 9463 or 3073F) can be used.
- The INCOM bus must be terminated with a 100 Ω terminating resistor, connected between the two cable strands at the circuit-breaker end.
- The maximum cable length is 3 km.

**Data access via Modbus**

The data for each circuit-breaker connected to the INCOM bus is contained in comprehensive data tables. Each data point is available as floating-point (IEEE) or fixed-point value. This variance allows the integration of the IZM to be adapted to the Modbus architecture. This allows a data filter to be easily implemented, which simplifies integration of the IZM data into the control system.

WWW.TM2A.PT info@tm2a.pt

WWW.TM2A.PT info@tm2a.pt



WWW.TM2A.PT info@tm2a.pt

WWW.TM2A.PT info@tm2a.pt



Switching capacity $I_{cu} = I_{cs}$ kA	Rated operational current $I_n = I_u$ A	Frame size	Setting range		Fixed mounted		Withdrawable units		Std. pack	
			Overload release $I_r$ A	Short-circuit releases		Part no. Article no.	Price See price list	Part no. Article no.		Price See price list
				Delayed $I_{sd} = I_r \times \dots$	Non-delayed $I_i = I_n \times \dots$					

**Circuit-breakers for system protection**

Including main terminals at rear and control circuit terminals according to ordered options.

Switching capacity	Rated operational current	Frame size	Setting range	Overload release	Short-circuit releases	Fixed mounted	Withdrawable units	Std. pack		
50	800	I <sub>ZM</sub> 20	320 – 800	-	2 - 10	I <sub>ZM</sub> 20B3-A08F 123400	I <sub>ZM</sub> 20B3-A08W 123160	1 off		
	1000		400 – 1000			I <sub>ZM</sub> 20B3-A10F 123401	I <sub>ZM</sub> 20B3-A10W 123161			
	1250		500 – 1250			I <sub>ZM</sub> 20B3-A12F 123402	I <sub>ZM</sub> 20B3-A12W 123162			
	1600		640 – 1600			I <sub>ZM</sub> 20B3-A16F 123403	I <sub>ZM</sub> 20B3-A16W 123163			
	2000		800 – 2000			I <sub>ZM</sub> 20B3-A20F 123404	I <sub>ZM</sub> 20B3-A20W 123164			
	65		800			I <sub>ZM</sub> 32	320 – 800		-	2 - 10
1000	400 – 1000	I <sub>ZM</sub> 20N3-A10F 123431	I <sub>ZM</sub> 20N3-A10W 123191							
1250	500 – 1250	I <sub>ZM</sub> 20N3-A12F 123432	I <sub>ZM</sub> 20N3-A12W 123192							
1600	640 – 1600	I <sub>ZM</sub> 20N3-A16F 123433	I <sub>ZM</sub> 20N3-A16W 123193							
2000	800 – 2000	I <sub>ZM</sub> 20N3-A20F 123434	I <sub>ZM</sub> 20N3-A20W 123194							
800	320 – 800	I <sub>ZM</sub> 32B3-A08F 123899	I <sub>ZM</sub> 32B3-A08W 123609							
1000	400 – 1000	I <sub>ZM</sub> 32B3-A10F 123900	I <sub>ZM</sub> 32B3-A10W 123610							
1250	500 – 1250	I <sub>ZM</sub> 32B3-A12F 123901	I <sub>ZM</sub> 32B3-A12W 123611							
1600	640 – 1600	I <sub>ZM</sub> 32B3-A16F 123902	I <sub>ZM</sub> 32B3-A16W 123612							
2000	800 – 2000	I <sub>ZM</sub> 32B3-A20F 123903	I <sub>ZM</sub> 32B3-A20W 123613							
2500	1000 – 2500	I <sub>ZM</sub> 32B3-A25F 123904	I <sub>ZM</sub> 32B3-A25W 123614							
3200	1280 – 3200	I <sub>ZM</sub> 32B3-A32F 123905	I <sub>ZM</sub> 32B3-A32W 123615							
85	800	I <sub>ZM</sub> 32N3	320 – 800	-	2 - 10		I <sub>ZM</sub> 32N3-A08F 123939	I <sub>ZM</sub> 32N3-A08W 123649		
	1000		400 – 1000				I <sub>ZM</sub> 32N3-A10F 123940	I <sub>ZM</sub> 32N3-A10W 123650		
	1250		500 – 1250			I <sub>ZM</sub> 32N3-A12F 123941	I <sub>ZM</sub> 32N3-A12W 123651			
	1600		640 – 1600			I <sub>ZM</sub> 32N3-A16F 123942	I <sub>ZM</sub> 32N3-A16W 123652			
	2000		800 – 2000			I <sub>ZM</sub> 32N3-A20F 123943	I <sub>ZM</sub> 32N3-A20W 123653			
	2500		1000 – 2500			I <sub>ZM</sub> 32N3-A25F 123944	I <sub>ZM</sub> 32N3-A25W 123654			
	3200		1280 – 3200			I <sub>ZM</sub> 32N3-A32F 123945	I <sub>ZM</sub> 32N3-A32W 123655			
	100		800			I <sub>ZM</sub> 32H3	320 – 800	-	2 - 10	I <sub>ZM</sub> 32H3-A08F 123979
1000		400 – 1000	I <sub>ZM</sub> 32H3-A10F 123980	I <sub>ZM</sub> 32H3-A10W 123690						
1250		500 – 1250	I <sub>ZM</sub> 32H3-A12F 123981	I <sub>ZM</sub> 32H3-A12W 123691						
1600		640 – 1600	I <sub>ZM</sub> 32H3-A16F 123982	I <sub>ZM</sub> 32H3-A16W 123692						
2000		800 – 2000	I <sub>ZM</sub> 32H3-A20F 123983	I <sub>ZM</sub> 32H3-A20W 123693						
2500		1000 – 2500	I <sub>ZM</sub> 32H3-A25F 123984	I <sub>ZM</sub> 32H3-A25W 123694						
3200		1280 – 3200	I <sub>ZM</sub> 32H3-A32F 123985	I <sub>ZM</sub> 32H3-A32W 123695						

WWW.TM2A.PT info@tm2a.pt

WWW.TM2A.PT info@tm2a.pt



Switching capacity	Rated operational current	Frame size	Setting range			Fixed mounted		Withdrawable units		Std. pack
			Overload release	Short-circuit releases		Part no. Article no.	Price See price list	Part no. Article no.	Price See price list	
				Delayed	Non-delayed					
$I_{cu} = I_{cs}$ kA	$I_n = I_u$ A		$I_r$ A	$I_{sd} = I_r \times \dots$	$I_i = I_n \times \dots$			Cassette must be ordered separately.		
<b>Selectively-opening circuit-breakers</b>										
Including main terminals at rear and control circuit terminals according to ordered options.										
50	800	IZM20	320 – 800	2 - 10	2 - 10, OFF	<b>I<sub>ZM</sub>20B3-V08F</b> 123406	<b>I<sub>ZM</sub>20B3-V08W</b> 123166	1 off		
	1000		400 – 1000			<b>I<sub>ZM</sub>20B3-V10F</b> 123407	<b>I<sub>ZM</sub>20B3-V10W</b> 123167			
	1250		500 – 1250			<b>I<sub>ZM</sub>20B3-V12F</b> 123408	<b>I<sub>ZM</sub>20B3-V12W</b> 123168			
	1600		640 – 1600			<b>I<sub>ZM</sub>20B3-V16F</b> 123409	<b>I<sub>ZM</sub>20B3-V16W</b> 123169			
	2000		800 – 2000			<b>I<sub>ZM</sub>20B3-V20F</b> 123410	<b>I<sub>ZM</sub>20B3-V20W</b> 123170			
	65	800	IZM20	320 – 800	2 - 10	2 - 10, OFF	<b>I<sub>ZM</sub>20N3-V08F</b> 123436		<b>I<sub>ZM</sub>20N3-V08W</b> 123196	
		1000		400 – 1000			<b>I<sub>ZM</sub>20N3-V10F</b> 123437		<b>I<sub>ZM</sub>20N3-V10W</b> 123197	
		1250		500 – 1250			<b>I<sub>ZM</sub>20N3-V12F</b> 123438		<b>I<sub>ZM</sub>20N3-V12W</b> 123198	
		1600		640 – 1600			<b>I<sub>ZM</sub>20N3-V16F</b> 123439		<b>I<sub>ZM</sub>20N3-V16W</b> 123199	
		2000		800 – 2000			<b>I<sub>ZM</sub>20N3-V20F</b> 123440		<b>I<sub>ZM</sub>20N3-V20W</b> 123200	
		65	800	IZM32	320 – 800	2 - 10	2 - 10, OFF		<b>I<sub>ZM</sub>32B3-V08F</b> 123907	<b>I<sub>ZM</sub>32B3-V08W</b> 123617
			1000		400 – 1000				<b>I<sub>ZM</sub>32B3-V10F</b> 123908	<b>I<sub>ZM</sub>32B3-V10W</b> 123618
			1250		500 – 1250				<b>I<sub>ZM</sub>32B3-V12F</b> 123909	<b>I<sub>ZM</sub>32B3-V12W</b> 123619
1600			640 – 1600		<b>I<sub>ZM</sub>32B3-V16F</b> 123910			<b>I<sub>ZM</sub>32B3-V16W</b> 123620		
2000			800 – 2000		<b>I<sub>ZM</sub>32B3-V20F</b> 123911			<b>I<sub>ZM</sub>32B3-V20W</b> 123621		
2500			1000 – 2500		<b>I<sub>ZM</sub>32B3-V25F</b> 123912			<b>I<sub>ZM</sub>32B3-V25W</b> 123622		
85			800	IZM32	320 – 800	2 - 10	2 - 10, OFF	<b>I<sub>ZM</sub>32N3-V08F</b> 123947	<b>I<sub>ZM</sub>32N3-V08W</b> 123657	
			1000		400 – 1000			<b>I<sub>ZM</sub>32N3-V10F</b> 123948	<b>I<sub>ZM</sub>32N3-V10W</b> 123658	
			1250		500 – 1250			<b>I<sub>ZM</sub>32N3-V12F</b> 123949	<b>I<sub>ZM</sub>32N3-V12W</b> 123659	
	1600		640 – 1600		<b>I<sub>ZM</sub>32N3-V16F</b> 123950			<b>I<sub>ZM</sub>32N3-V16W</b> 123660		
	2000		800 – 2000		<b>I<sub>ZM</sub>32N3-V20F</b> 123951			<b>I<sub>ZM</sub>32N3-V20W</b> 123661		
	2500		1000 – 2500		<b>I<sub>ZM</sub>32N3-V25F</b> 123952			<b>I<sub>ZM</sub>32N3-V25W</b> 123662		
	85		3200	IZM32	1280 – 3200	2 - 10	2 - 10, OFF	<b>I<sub>ZM</sub>32N3-V32F</b> 123953	<b>I<sub>ZM</sub>32N3-V32W</b> 123663	
			4000		IZM40			1600 – 4000	<b>I<sub>ZM</sub>40N3-V40F</b> 124303	<b>I<sub>ZM</sub>40N3-V40W</b> 124193
			4000					IZM63	1600 – 4000	<b>I<sub>ZM</sub>63N3-V40F</b> 124304
		5000	2000 – 5000	<b>I<sub>ZM</sub>63N3-V50F</b> 124305	<b>I<sub>ZM</sub>63N3-V50W</b> 124195					
		6300	2520 – 6300	<b>I<sub>ZM</sub>63N3-V63F</b> 124306	<b>I<sub>ZM</sub>63N3-V63W</b> 124196					

WWW.TM2A.PT info@tm2a.pt

WWW.TM2A.PT info@tm2a.pt





Switching capacity $I_{cu} = I_{cs}$ kA	Rated operational current $I_n = I_u$ A	Frame size	Setting range		Fixed mounted		Withdrawable units		Std. pack	
			Overload release $I_r$ A	Short-circuit releases		Part no. Article no.	Price See price list	Part no. Article no.		Price See price list
				Delayed $I_{sd} = I_r \times \dots$	Non-delayed $I_i = I_n \times \dots$					
<b>Circuit-breaker for universal protection</b>										
Including main terminals at rear and control circuit terminals according to ordered options.										
85	800	I <sub>ZM</sub> 32	320 – 800	2 - 10	2 - 10, OFF	I <sub>ZM</sub> 32N3-U08F 123955		I <sub>ZM</sub> 32N3-U08W 123665	1 off	
	1000		400 – 1000			I <sub>ZM</sub> 32N3-U10F 123956		I <sub>ZM</sub> 32N3-U10W 123666		
	1250		500 – 1250			I <sub>ZM</sub> 32N3-U12F 123957		I <sub>ZM</sub> 32N3-U12W 123667		
	1600		640 – 1600			I <sub>ZM</sub> 32N3-U16F 123958		I <sub>ZM</sub> 32N3-U16W 123668		
	2000		800 – 2000			I <sub>ZM</sub> 32N3-U20F 123959		I <sub>ZM</sub> 32N3-U20W 123669		
	2500		1000 – 2500			I <sub>ZM</sub> 32N3-U25F 123960		I <sub>ZM</sub> 32N3-U25W 123670		
	3200		1280 – 3200			I <sub>ZM</sub> 32N3-U32F 123961		I <sub>ZM</sub> 32N3-U32W 123671		
	4000	I <sub>ZM</sub> 40	1600 – 4000			I <sub>ZM</sub> 40N3-U40F 124307		I <sub>ZM</sub> 40N3-U40W 124197		
	4000	I <sub>ZM</sub> 63	1600 – 4000			I <sub>ZM</sub> 63N3-U40F 124308		I <sub>ZM</sub> 63N3-U40W 124198		
	5000		2000 – 5000			I <sub>ZM</sub> 63N3-U50F 124309		I <sub>ZM</sub> 63N3-U50W 124199		
	6300		2520 – 6300			I <sub>ZM</sub> 63N3-U63F 124310		I <sub>ZM</sub> 63N3-U63W 124200		
100	800	I <sub>ZM</sub> 32	320 – 800			I <sub>ZM</sub> 32H3-U08F 123995		I <sub>ZM</sub> 32H3-U08W 123705		
	1000		400 – 1000			I <sub>ZM</sub> 32H3-U10F 123996		I <sub>ZM</sub> 32H3-U10W 123706		
	1250		500 – 1250			I <sub>ZM</sub> 32H3-U12F 123997		I <sub>ZM</sub> 32H3-U12W 123707		
	1600		640 – 1600			I <sub>ZM</sub> 32H3-U16F 123998		I <sub>ZM</sub> 32H3-U16W 123708		
	2000		800 – 2000			I <sub>ZM</sub> 32H3-U20F 123999		I <sub>ZM</sub> 32H3-U20W 123709		
	2500		1000 – 2500			I <sub>ZM</sub> 32H3-U25F 124000		I <sub>ZM</sub> 32H3-U25W 123710		
	3200		1280 – 3200			I <sub>ZM</sub> 32H3-U32F 124001		I <sub>ZM</sub> 32H3-U32W 123711		
	4000	I <sub>ZM</sub> 40	1600 – 4000			I <sub>ZM</sub> 40H3-U40F 124327		I <sub>ZM</sub> 40H3-U40W 124217		
	4000	I <sub>ZM</sub> 63	1600 – 4000			I <sub>ZM</sub> 63H3-U40F 124328		I <sub>ZM</sub> 63H3-U40W 124218		
	5000		2000 – 5000			I <sub>ZM</sub> 63H3-U50F 124329		I <sub>ZM</sub> 63H3-U50W 124219		
	6300		2520 – 6300			I <sub>ZM</sub> 63H3-U63F 124330		I <sub>ZM</sub> 63H3-U63W 124220		

WWW.TM2A.PT info@tm2a.pt

WWW.TM2A.PT info@tm2a.pt



Switching capacity $I_{cu} = I_{cs}$ kA	Rated operational current $I_n = I_u$ A	Frame size	Setting range		Fixed mounted		Withdrawable units		Std. pack	
			Overload release $I_r$ A	Short-circuit releases		Part no. Article no.	Price See price list	Part no. Article no.		Price See price list
				Delayed $I_{sd} = I_r \times \dots$	Non-delayed $I_i = I_n \times \dots$					
<b>Circuit-breaker for universal protection with power monitoring</b>										
Including main terminals at rear and control circuit terminals according to ordered options.										
50	800	I <sub>ZM</sub> 20	320 – 800	2 - 10	2 - 10, OFF	<b>I<sub>ZM</sub>20B3-P08F</b> 123418		<b>I<sub>ZM</sub>20B3-P08W</b> 123178	1 off	
	1000		400 – 1000			<b>I<sub>ZM</sub>20B3-P10F</b> 123419		<b>I<sub>ZM</sub>20B3-P10W</b> 123179		
	1250		500 – 1250			<b>I<sub>ZM</sub>20B3-P12F</b> 123420		<b>I<sub>ZM</sub>20B3-P12W</b> 123180		
	1600		640 – 1600			<b>I<sub>ZM</sub>20B3-P16F</b> 123421		<b>I<sub>ZM</sub>20B3-P16W</b> 123181		
	2000		800 – 2000			<b>I<sub>ZM</sub>20B3-P20F</b> 123422		<b>I<sub>ZM</sub>20B3-P20W</b> 123182		
65	800	I <sub>ZM</sub> 20	320 – 800	2 - 10, OFF	<b>I<sub>ZM</sub>20N3-P08F</b> 123448		<b>I<sub>ZM</sub>20N3-P08W</b> 123208			
	1000		400 – 1000		<b>I<sub>ZM</sub>20N3-P10F</b> 123449		<b>I<sub>ZM</sub>20N3-P10W</b> 123209			
	1250		500 – 1250		<b>I<sub>ZM</sub>20N3-P12F</b> 123450		<b>I<sub>ZM</sub>20N3-P12W</b> 123210			
	1600		640 – 1600		<b>I<sub>ZM</sub>20N3-P16F</b> 123451		<b>I<sub>ZM</sub>20N3-P16W</b> 123211			
	2000		800 – 2000		<b>I<sub>ZM</sub>20N3-P20F</b> 123452		<b>I<sub>ZM</sub>20N3-P20W</b> 123212			
	800	I <sub>ZM</sub> 32	320 – 800		<b>I<sub>ZM</sub>32B3-P08F</b> 123923		<b>I<sub>ZM</sub>32B3-P08W</b> 123633			
	1000		400 – 1000		<b>I<sub>ZM</sub>32B3-P10F</b> 123924		<b>I<sub>ZM</sub>32B3-P10W</b> 123634			
	1250		500 – 1250		<b>I<sub>ZM</sub>32B3-P12F</b> 123925		<b>I<sub>ZM</sub>32B3-P12W</b> 123635			
	1600		640 – 1600		<b>I<sub>ZM</sub>32B3-P16F</b> 123926		<b>I<sub>ZM</sub>32B3-P16W</b> 123636			
	2000		800 – 2000		<b>I<sub>ZM</sub>32B3-P20F</b> 123927		<b>I<sub>ZM</sub>32B3-P20W</b> 123637			
85	2500	I <sub>ZM</sub> 32	1000 – 2500	<b>I<sub>ZM</sub>32B3-P25F</b> 123928		<b>I<sub>ZM</sub>32B3-P25W</b> 123638				
	3200		1280 – 3200	<b>I<sub>ZM</sub>32B3-P32F</b> 123929		<b>I<sub>ZM</sub>32B3-P32W</b> 123639				
	800		I <sub>ZM</sub> 32N3	320 – 800	<b>I<sub>ZM</sub>32N3-P08F</b> 123963		<b>I<sub>ZM</sub>32N3-P08W</b> 123673			
	1000			400 – 1000	<b>I<sub>ZM</sub>32N3-P10F</b> 123964		<b>I<sub>ZM</sub>32N3-P10W</b> 123674			
	1250			500 – 1250	<b>I<sub>ZM</sub>32N3-P12F</b> 123965		<b>I<sub>ZM</sub>32N3-P12W</b> 123675			
	1600	640 – 1600		<b>I<sub>ZM</sub>32N3-P16F</b> 123966		<b>I<sub>ZM</sub>32N3-P16W</b> 123676				
	2000	800 – 2000		<b>I<sub>ZM</sub>32N3-P20F</b> 123967		<b>I<sub>ZM</sub>32N3-P20W</b> 123677				
	4000	2500	I <sub>ZM</sub> 40	1000 – 2500	<b>I<sub>ZM</sub>32N3-P25F</b> 123968		<b>I<sub>ZM</sub>32N3-P25W</b> 123678			
		3200		1280 – 3200	<b>I<sub>ZM</sub>32N3-P32F</b> 123969		<b>I<sub>ZM</sub>32N3-P32W</b> 123679			
		4000		1600 – 4000	<b>I<sub>ZM</sub>40N3-P40F</b> 124311		<b>I<sub>ZM</sub>40N3-P40W</b> 124201			
4000		I <sub>ZM</sub> 63		1600 – 4000	<b>I<sub>ZM</sub>63N3-P40F</b> 124312		<b>I<sub>ZM</sub>63N3-P40W</b> 124202			
5000				2000 – 5000	<b>I<sub>ZM</sub>63N3-P50F</b> 124313		<b>I<sub>ZM</sub>63N3-P50W</b> 124203			
6300	2520 – 6300	<b>I<sub>ZM</sub>63N3-P63F</b> 124314		<b>I<sub>ZM</sub>63N3-P63W</b> 124204						

WWW.TM2A.PT info@tm2a.pt

WWW.TM2A.PT info@tm2a.pt





Switching capacity $I_{cu} = I_{cs}$ kA	Rated operational current $I_n = I_u$ A	Frame size	Setting range			Fixed mounted		Withdrawable units		Std. pack
			Overload release $I_r$ A	Short-circuit releases		Part no. Article no.	Price See price list	Part no. Article no.	Price See price list	
				Delayed $I_{sd} = I_r \times \dots$	Non-delayed $I_i = I_n \times \dots$					
<b>Circuit-breaker for universal protection with power monitoring</b>										
Including main terminals at rear and control circuit terminals according to ordered options.										
100	800	IZM32	320 – 800	2 - 10	2 - 10, OFF	<b>IZM32H3-P08F</b> 124003		<b>IZM32H3-P08W</b> 123713		1 off
	1000		400 – 1000			<b>IZM32H3-P10F</b> 124004		<b>IZM32H3-P10W</b> 123714		
	1250		500 – 1250			<b>IZM32H3-P12F</b> 124005		<b>IZM32H3-P12W</b> 123715		
	1600		640 – 1600			<b>IZM32H3-P16F</b> 124006		<b>IZM32H3-P16W</b> 123716		
	2000		800 – 2000			<b>IZM32H3-P20F</b> 124007		<b>IZM32H3-P20W</b> 123717		
	2500		1000 – 2500			<b>IZM32H3-P25F</b> 124008		<b>IZM32H3-P25W</b> 123718		
	3200		1280 – 3200			<b>IZM32H3-P32F</b> 124009		<b>IZM32H3-P32W</b> 123719		
	4000	IZM40	1600 – 4000			<b>IZM40H3-P40F</b> 124331		<b>IZM40H3-P40W</b> 124221		
	4000		IZM63	1600 – 4000			<b>IZM63H3-P40F</b> 124332		<b>IZM63H3-P40W</b> 124222	
	5000	2000 – 5000		<b>IZM63H3-P50F</b> 124333		<b>IZM63H3-P50W</b> 124223				
	6300	2520 – 6300		<b>IZM63H3-P63F</b> 124334		<b>IZM63H3-P63W</b> 124224				

info@tm2a.pt

info@tm2a.pt

WWW.TM2A.PT

WWW.TM2A.PT

Switching capacity $I_{cu} = I_{cs}$ kA	Rated operational current $I_n = I_u$ A	Setting range Overload release $I_r$ A	Short-circuit releases		Fixed mounted Part no. Article no.	Price See price list	Withdrawable units Part no. Article no.	Price See price list	Std. pack		
			Delayed $I_{sd} = I_r \times \dots$	Non-delayed $I_i = I_n \times \dots$						Cassette must be ordered separately.	
<b>I ZM32 for 1100 V</b>											
Including main terminals at rear and control circuit terminals according to ordered options.											
<b>Circuit-breakers for system protection</b>											
25	3200	1280 – 3200	–	2 - 10	<b>IZM32S3-A32F-1100V</b> 123725		<b>IZM32S3-A32W-1100V</b> 123721		1 off		
<b>Selectively-opening circuit-breakers</b>											
25	3200	1280 – 3200	2 - 10	2 - 10, OFF	<b>IZM32S3-V32F-1100V</b> 123726		<b>IZM32S3-V32W-1100V</b> 123722		1 off		
<b>Circuit-breaker for universal protection</b>											
25	3200	1280 – 3200	2 - 10	2 - 10, OFF	<b>IZM32S3-U32F-1100V</b> 123727		<b>IZM32S3-U32W-1100V</b> 123723		1 off		
<b>Circuit-breaker with circuit-breaker</b>											
25	3200	1280 – 3200	2 - 10	2 - 10, OFF	<b>IZM32S3-P32F-1100V</b> 123749		<b>IZM32S3-P32W-1100V</b> 123724		1 off		



Switching capacity	Rated operational current	Frame size	Setting range		Fixed mounted	Withdrawable units		Std. pack	
			Overload release	Short-circuit releases		Part no. Article no.	Price See price list		
				Delayed					Non-delayed
$I_{cu} = I_{cs}$ kA	$I_n = I_u$ A		$I_r$ A	$I_{sd} = I_r \times \dots$	$I_i = I_n \times \dots$				
<b>Circuit-breakers for system protection</b>									
Including main terminals at rear and control circuit terminals according to ordered options.									
50	800	I <sub>ZM</sub> 20	320 – 800	–	2 - 10	I <sub>ZM</sub> 20B4-A08F 123520	I <sub>ZM</sub> 20B4-A08W 123280	1 off	
	1000		400 – 1000			I <sub>ZM</sub> 20B4-A10F 123521	I <sub>ZM</sub> 20B4-A10W 123281		
	1250		500 – 1250			I <sub>ZM</sub> 20B4-A12F 123522	I <sub>ZM</sub> 20B4-A12W 123282		
	1600		640 – 1600			I <sub>ZM</sub> 20B4-A16F 123523	I <sub>ZM</sub> 20B4-A16W 123283		
	2000		800 – 2000			I <sub>ZM</sub> 20B4-A20F 123524	I <sub>ZM</sub> 20B4-A20W 123284		
65	800		320 – 800			I <sub>ZM</sub> 20N4-A08F 123550	I <sub>ZM</sub> 20N4-A08W 123310		
	1000		400 – 1000			I <sub>ZM</sub> 20N4-A10F 123551	I <sub>ZM</sub> 20N4-A10W 123311		
	1250		500 – 1250			I <sub>ZM</sub> 20N4-A12F 123552	I <sub>ZM</sub> 20N4-A12W 123312		
	1600		640 – 1600			I <sub>ZM</sub> 20N4-A16F 123553	I <sub>ZM</sub> 20N4-A16W 123313		
	2000		800 – 2000			I <sub>ZM</sub> 20N4-A20F 123554	I <sub>ZM</sub> 20N4-A20W 123314		
	800	I <sub>ZM</sub> 32	320 – 800			I <sub>ZM</sub> 32B4-A08F 124044	I <sub>ZM</sub> 32B4-A08W 123754		
	1000		400 – 1000			I <sub>ZM</sub> 32B4-A10F 124045	I <sub>ZM</sub> 32B4-A10W 123755		
	1250		500 – 1250			I <sub>ZM</sub> 32B4-A12F 124046	I <sub>ZM</sub> 32B4-A12W 123756		
	1600		640 – 1600			I <sub>ZM</sub> 32B4-A16F 124047	I <sub>ZM</sub> 32B4-A16W 123757		
	2000		800 – 2000			I <sub>ZM</sub> 32B4-A20F 124048	I <sub>ZM</sub> 32B4-A20W 123758		
	2500		1000 – 2500			I <sub>ZM</sub> 32B4-A25F 124049	I <sub>ZM</sub> 32B4-A25W 123759		
	3200		1280 – 3200			I <sub>ZM</sub> 32B4-A32F 124050	I <sub>ZM</sub> 32B4-A32W 123760		
85	800		320 – 800			I <sub>ZM</sub> 32N4-A08F 124084	I <sub>ZM</sub> 32N4-A08W 123794		
	1000		400 – 1000			I <sub>ZM</sub> 32N4-A10F 124085	I <sub>ZM</sub> 32N4-A10W 123795		
	1250		500 – 1250			I <sub>ZM</sub> 32N4-A12F 124086	I <sub>ZM</sub> 32N4-A12W 123796		
	1600		640 – 1600			I <sub>ZM</sub> 32N4-A16F 124087	I <sub>ZM</sub> 32N4-A16W 123797		
	2000		800 – 2000			I <sub>ZM</sub> 32N4-A20F 124088	I <sub>ZM</sub> 32N4-A20W 123798		
	2500		1000 – 2500			I <sub>ZM</sub> 32N4-A25F 124089	I <sub>ZM</sub> 32N4-A25W 123799		
	3200		1280 – 3200			I <sub>ZM</sub> 32N4-A32F 124090	I <sub>ZM</sub> 32N4-A32W 123800		
100	800		320 – 800			I <sub>ZM</sub> 32H4-A08F 124124	I <sub>ZM</sub> 32H4-A08W 123834		
	1000		400 – 1000			I <sub>ZM</sub> 32H4-A10F 124125	I <sub>ZM</sub> 32H4-A10W 123835		
	1250		500 – 1250			I <sub>ZM</sub> 32H4-A12F 124126	I <sub>ZM</sub> 32H4-A12W 123836		
	1600		640 – 1600			I <sub>ZM</sub> 32H4-A16F 124127	I <sub>ZM</sub> 32H4-A16W 123837		
	2000		800 – 2000			I <sub>ZM</sub> 32H4-A20F 124128	I <sub>ZM</sub> 32H4-A20W 123838		
	2500		1000 – 2500			I <sub>ZM</sub> 32H4-A25F 124129	I <sub>ZM</sub> 32H4-A25W 123839		
	3200		1280 – 3200			I <sub>ZM</sub> 32H4-A32F 124130	I <sub>ZM</sub> 32H4-A32W 123840		

WWW.TM2A.PT info@tm2a.pt

WWW.TM2A.PT info@tm2a.pt



Switching capacity $I_{cu} = I_{cs}$ kA	Rated operational current $I_n = I_u$ A	Frame size	Setting range		Fixed mounted		Withdrawable units		Std. pack	
			Overload release $I_r$ A	Short-circuit releases		Part no. Article no.	Price See price list	Part no. Article no.		Price See price list
				Delayed $I_{sd} = I_r \times \dots$	Non-delayed $I_i = I_n \times \dots$					

Selectively-opening circuit-breakers

Including main terminals at rear and control circuit terminals according to ordered options.

Switching capacity (kA)	Rated operational current (A)	Frame size	Overload release (A)	Short-circuit releases (Delayed)	Short-circuit releases (Non-delayed)	Fixed mounted (Part no. / Article no.)	Fixed mounted (Price)	Withdrawable units (Part no. / Article no.)	Withdrawable units (Price)	Std. pack
50	800	I <sub>ZM</sub> 20	320 – 800	2 - 10	2 - 10, OFF	I <sub>ZM</sub> 20B4-V08F / 123526		I <sub>ZM</sub> 20B4-V08W / 123286		1 off
	1000		400 – 1000			I <sub>ZM</sub> 20B4-V10F / 123527		I <sub>ZM</sub> 20B4-V10W / 123287		
	1250		500 – 1250			I <sub>ZM</sub> 20B4-V12F / 123528		I <sub>ZM</sub> 20B4-V12W / 123288		
	1600		640 – 1600			I <sub>ZM</sub> 20B4-V16F / 123529		I <sub>ZM</sub> 20B4-V16W / 123289		
	2000		800 – 2000			I <sub>ZM</sub> 20B4-V20F / 123530		I <sub>ZM</sub> 20B4-V20W / 123290		
65	800	I <sub>ZM</sub> 20	320 – 800			I <sub>ZM</sub> 20N4-V08F / 123556		I <sub>ZM</sub> 20N4-V08W / 123316		
	1000		400 – 1000			I <sub>ZM</sub> 20N4-V10F / 123557		I <sub>ZM</sub> 20N4-V10W / 123317		
	1250		500 – 1250			I <sub>ZM</sub> 20N4-V12F / 123558		I <sub>ZM</sub> 20N4-V12W / 123318		
	1600		640 – 1600			I <sub>ZM</sub> 20N4-V16F / 123559		I <sub>ZM</sub> 20N4-V16W / 123319		
	2000		800 – 2000			I <sub>ZM</sub> 20N4-V20F / 123560		I <sub>ZM</sub> 20N4-V20W / 123320		
	800	I <sub>ZM</sub> 32	320 – 800			I <sub>ZM</sub> 32B4-V08F / 124052		I <sub>ZM</sub> 32B4-V08W / 123762		
	1000		400 – 1000			I <sub>ZM</sub> 32B4-V10F / 124053		I <sub>ZM</sub> 32B4-V10W / 123763		
	1250		500 – 1250			I <sub>ZM</sub> 32B4-V12F / 124054		I <sub>ZM</sub> 32B4-V12W / 123764		
	1600		640 – 1600			I <sub>ZM</sub> 32B4-V16F / 124055		I <sub>ZM</sub> 32B4-V16W / 123765		
	2000		800 – 2000			I <sub>ZM</sub> 32B4-V20F / 124056		I <sub>ZM</sub> 32B4-V20W / 123766		
2500	1000 – 2500			I <sub>ZM</sub> 32B4-V25F / 124057		I <sub>ZM</sub> 32B4-V25W / 123767				
3200	1280 – 3200			I <sub>ZM</sub> 32B4-V32F / 124058		I <sub>ZM</sub> 32B4-V32W / 123768				
85	800	I <sub>ZM</sub> 32	320 – 800			I <sub>ZM</sub> 32N4-V08F / 124092		I <sub>ZM</sub> 32N4-V08W / 123802		
	1000		400 – 1000			I <sub>ZM</sub> 32N4-V10F / 124093		I <sub>ZM</sub> 32N4-V10W / 123803		
	1250		500 – 1250			I <sub>ZM</sub> 32N4-V12F / 124094		I <sub>ZM</sub> 32N4-V12W / 123804		
	1600		640 – 1600			I <sub>ZM</sub> 32N4-V16F / 124095		I <sub>ZM</sub> 32N4-V16W / 123805		
	2000		800 – 2000			I <sub>ZM</sub> 32N4-V20F / 124096		I <sub>ZM</sub> 32N4-V20W / 123806		
	2500		1000 – 2500			I <sub>ZM</sub> 32N4-V25F / 124097		I <sub>ZM</sub> 32N4-V25W / 123807		
	3200		1280 – 3200			I <sub>ZM</sub> 32N4-V32F / 124098		I <sub>ZM</sub> 32N4-V32W / 123808		
	4000	I <sub>ZM</sub> 40	1600 – 4000			I <sub>ZM</sub> 40N4-V40F / 124358		I <sub>ZM</sub> 40N4-V40W / 124248		
	4000	I <sub>ZM</sub> 63	1600 – 4000			I <sub>ZM</sub> 63N4-V40F / 124359		I <sub>ZM</sub> 63N4-V40W / 124249		
	5000		2000 – 5000			I <sub>ZM</sub> 63N4-V50F / 124360		I <sub>ZM</sub> 63N4-V50W / 124250		
	6300		2520 – 6300			I <sub>ZM</sub> 63N4-V63F / 124361		I <sub>ZM</sub> 63N4-V63W / 124251		

WWW.TM2A.PT info@tm2a.pt

WWW.TM2A.PT info@tm2a.pt



Switching capacity	Rated operational current	Frame size	Setting range		Fixed mounted		Withdrawable units		Std. pack
			Overload release	Short-circuit releases	Part no. Article no.	Price See price list	Part no. Article no.	Price See price list	
$I_{cu} = I_{cs}$ kA	$I_n = I_u$ A		$I_r$ A	Delayed $I_{sd} = I_r \times \dots$	Non-delayed $I_i = I_n \times \dots$			Cassette must be ordered separately.	

**Selectively-opening circuit-breakers**

Including main terminals at rear and control circuit terminals according to ordered options.

Switching capacity	Rated operational current	Frame size	Overload release	Short-circuit releases	Fixed mounted Part no. Article no.	Price	Withdrawable units Part no. Article no.	Price	Std. pack		
100	800	I <sub>ZM</sub> 32	320 – 800	2 - 10	2 - 10, OFF	I <sub>ZM</sub> 32H4-V08F 124132		I <sub>ZM</sub> 32H4-V08W 123842	1 off		
	1000		400 – 1000			I <sub>ZM</sub> 32H4-V10F 124133		I <sub>ZM</sub> 32H4-V10W 123843			
	1250		500 – 1250			I <sub>ZM</sub> 32H4-V12F 124134		I <sub>ZM</sub> 32H4-V12W 123844			
	1600		640 – 1600			I <sub>ZM</sub> 32H4-V16F 124135		I <sub>ZM</sub> 32H4-V16W 123845			
	2000		800 – 2000			I <sub>ZM</sub> 32H4-V20F 124136		I <sub>ZM</sub> 32H4-V20W 123846			
	2500		1000 – 2500			I <sub>ZM</sub> 32H4-V25F 124137		I <sub>ZM</sub> 32H4-V25W 123847			
	3200		1280 – 3200			I <sub>ZM</sub> 32H4-V32F 124138		I <sub>ZM</sub> 32H4-V32W 123848			
	4000		I <sub>ZM</sub> 40			1600 – 4000		I <sub>ZM</sub> 40H4-V40F 124378		I <sub>ZM</sub> 40H4-V40W 124268	
	4000					I <sub>ZM</sub> 63		1600 – 4000		I <sub>ZM</sub> 63H4-V40F 124379	I <sub>ZM</sub> 63H4-V40W 124269
	5000							2000 – 5000		I <sub>ZM</sub> 63H4-V50F 124380	I <sub>ZM</sub> 63H4-V50W 124270
6300		2520 – 6300	I <sub>ZM</sub> 63H4-V63F 124381	I <sub>ZM</sub> 63H4-V63W 124271							

**Circuit-breaker for universal protection**

Including main terminals at rear and control circuit terminals according to ordered options.

Switching capacity	Rated operational current	Frame size	Overload release	Short-circuit releases	Fixed mounted Part no. Article no.	Price	Withdrawable units Part no. Article no.	Price	Std. pack						
50	800	I <sub>ZM</sub> 20	320 – 800	2 - 10	2 - 10, OFF	I <sub>ZM</sub> 20B4-U08F 123532		I <sub>ZM</sub> 20B4-U08W 123292	1 off						
	1000		400 – 1000			I <sub>ZM</sub> 20B4-U10F 123533		I <sub>ZM</sub> 20B4-U10W 123293							
	1250		500 – 1250			I <sub>ZM</sub> 20B4-U12F 123534		I <sub>ZM</sub> 20B4-U12W 123294							
	1600		640 – 1600			I <sub>ZM</sub> 20B4-U16F 123535		I <sub>ZM</sub> 20B4-U16W 123295							
	2000		800 – 2000			I <sub>ZM</sub> 20B4-U20F 123536		I <sub>ZM</sub> 20B4-U20W 123296							
	65		800			I <sub>ZM</sub> 20		320 – 800		2 - 10	2 - 10, OFF	I <sub>ZM</sub> 20N4-U08F 123562		I <sub>ZM</sub> 20N4-U08W 123322	1 off
			1000					400 – 1000				I <sub>ZM</sub> 20N4-U10F 123563		I <sub>ZM</sub> 20N4-U10W 123323	
			1250					500 – 1250				I <sub>ZM</sub> 20N4-U12F 123564		I <sub>ZM</sub> 20N4-U12W 123324	
			1600					640 – 1600				I <sub>ZM</sub> 20N4-U16F 123565		I <sub>ZM</sub> 20N4-U16W 123325	
			2000					800 – 2000				I <sub>ZM</sub> 20N4-U20F 123566		I <sub>ZM</sub> 20N4-U20W 123326	
800		I <sub>ZM</sub> 32	320 – 800	2 - 10	2 - 10, OFF		I <sub>ZM</sub> 32B4-U08F 124060		I <sub>ZM</sub> 32B4-U08W 123770			1 off			
1000			400 – 1000				I <sub>ZM</sub> 32B4-U10F 124061		I <sub>ZM</sub> 32B4-U10W 123771						
1250			500 – 1250				I <sub>ZM</sub> 32B4-U12F 124062		I <sub>ZM</sub> 32B4-U12W 123772						
1600			640 – 1600				I <sub>ZM</sub> 32B4-U16F 124063		I <sub>ZM</sub> 32B4-U16W 123773						
2000			800 – 2000				I <sub>ZM</sub> 32B4-U20F 124064		I <sub>ZM</sub> 32B4-U20W 123774						
2500	1000 – 2500		I <sub>ZM</sub> 32B4-U25F 124065			I <sub>ZM</sub> 32B4-U25W 123775									
3200		1280 – 3200	I <sub>ZM</sub> 32B4-U32F 124066	I <sub>ZM</sub> 32B4-U32W 123776											

info@tm2a.pt

WWW.TM2A.PT

info@tm2a.pt

WWW.TM2A.PT



Switching capacity $I_{cu} = I_{cs}$ kA	Rated operational current $I_n = I_u$ A	Frame size	Setting range			Fixed mounted		Withdrawable units		Std. pack
			Overload release $I_r$ A	Short-circuit releases		Part no. Article no.	Price See price list	Part no. Article no.	Price See price list	
				Delayed $I_{sd} = I_r \times \dots$	Non-delayed $I_i = I_n \times \dots$					
<b>Circuit-breaker for universal protection</b>										
Including main terminals at rear and control circuit terminals according to ordered options.										
85	800	I <sub>ZM</sub> 32	320 – 800	2 - 10	2 - 10, OFF	I <sub>ZM</sub> 32N4-U08F 124100		I <sub>ZM</sub> 32N4-U08W 123810		1 off
	1000		400 – 1000			I <sub>ZM</sub> 32N4-U10F 124101		I <sub>ZM</sub> 32N4-U10W 123811		
	1250		500 – 1250			I <sub>ZM</sub> 32N4-U12F 124102		I <sub>ZM</sub> 32N4-U12W 123812		
	1600		640 – 1600			I <sub>ZM</sub> 32N4-U16F 124103		I <sub>ZM</sub> 32N4-U16W 123813		
	2000		800 – 2000			I <sub>ZM</sub> 32N4-U20F 124104		I <sub>ZM</sub> 32N4-U20W 123814		
	2500		1000 – 2500			I <sub>ZM</sub> 32N4-U25F 124105		I <sub>ZM</sub> 32N4-U25W 123815		
	3200		1280 – 3200			I <sub>ZM</sub> 32N4-U32F 124106		I <sub>ZM</sub> 32N4-U32W 123816		
	4000	I <sub>ZM</sub> 40	1600 – 4000			I <sub>ZM</sub> 40N4-U40F 124362		I <sub>ZM</sub> 40N4-U40W 124252		
	4000	I <sub>ZM</sub> 63	1600 – 4000			I <sub>ZM</sub> 63N4-U40F 124363		I <sub>ZM</sub> 63N4-U40W 124253		
	5000		2000 – 5000			I <sub>ZM</sub> 63N4-U50F 124364		I <sub>ZM</sub> 63N4-U50W 124254		
	6300		2520 – 6300			I <sub>ZM</sub> 63N4-U63F 124365		I <sub>ZM</sub> 63N4-U63W 124255		
100	800	I <sub>ZM</sub> 32	320 – 800			I <sub>ZM</sub> 32H4-U08F 124140		I <sub>ZM</sub> 32H4-U08W 123850		
	1000		400 – 1000			I <sub>ZM</sub> 32H4-U10F 124141		I <sub>ZM</sub> 32H4-U10W 123851		
	1250		500 – 1250			I <sub>ZM</sub> 32H4-U12F 124142		I <sub>ZM</sub> 32H4-U12W 123852		
	1600		640 – 1600			I <sub>ZM</sub> 32H4-U16F 124143		I <sub>ZM</sub> 32H4-U16W 123853		
	2000		800 – 2000			I <sub>ZM</sub> 32H4-U20F 124144		I <sub>ZM</sub> 32H4-U20W 123854		
	2500		1000 – 2500			I <sub>ZM</sub> 32H4-U25F 124145		I <sub>ZM</sub> 32H4-U25W 123855		
	3200		1280 – 3200			I <sub>ZM</sub> 32H4-U32F 124146		I <sub>ZM</sub> 32H4-U32W 123856		
	4000	I <sub>ZM</sub> 40	1600 – 4000			I <sub>ZM</sub> 40H4-U40F 124382		I <sub>ZM</sub> 40H4-U40W 124272		
	4000	I <sub>ZM</sub> 63	1600 – 4000			I <sub>ZM</sub> 63H4-U40F 124383		I <sub>ZM</sub> 63H4-U40W 124273		
	5000		2000 – 5000			I <sub>ZM</sub> 63H4-U50F 124384		I <sub>ZM</sub> 63H4-U50W 124274		
	6300		2520 – 6300			I <sub>ZM</sub> 63H4-U63F 124385		I <sub>ZM</sub> 63H4-U63W 124275		

WWW.TM2A.PT info@tm2a.pt

WWW.TM2A.PT info@tm2a.pt



Switching capacity $I_{cu} = I_{cs}$ kA	Rated operational current $I_n = I_u$ A	Frame size	Setting range		Fixed mounted Part no. Article no.	Price See price list	Withdrawable units		Std. pack	
			Overload release $I_r$ A	Short-circuit releases			Part no. Article no.	Price See price list		
				Delayed $I_{sd} = I_r \times \dots$						Non-delayed $I_i = I_n \times \dots$
							Cassette must be ordered separately.			
<b>Circuit-breaker for universal protection with power monitoring</b>										
Including main terminals at rear and control circuit terminals according to ordered options.										
50	800	I <sub>ZM</sub> 20	320 – 800	2 - 10	2 - 10, OFF	I <sub>ZM</sub> 20B4-P08F 123538	I <sub>ZM</sub> 20B4-P08W 123298	1 off		
	1000		400 – 1000			I <sub>ZM</sub> 20B4-P10F 123539	I <sub>ZM</sub> 20B4-P10W 123299			
	1250		500 – 1250			I <sub>ZM</sub> 20B4-P12F 123540	I <sub>ZM</sub> 20B4-P12W 123300			
	1600		640 – 1600			I <sub>ZM</sub> 20B4-P16F 123541	I <sub>ZM</sub> 20B4-P16W 123301			
	2000		800 – 2000			I <sub>ZM</sub> 20B4-P20F 123542	I <sub>ZM</sub> 20B4-P20W 123302			
65	800		I <sub>ZM</sub> 32			320 – 800	2 - 10		2 - 10, OFF	I <sub>ZM</sub> 20N4-P08F 123568
	1000	400 – 1000		I <sub>ZM</sub> 20N4-P10F 123569	I <sub>ZM</sub> 20N4-P10W 123329					
	1250	500 – 1250		I <sub>ZM</sub> 20N4-P12F 123570	I <sub>ZM</sub> 20N4-P12W 123330					
	1600	640 – 1600		I <sub>ZM</sub> 20N4-P16F 123571	I <sub>ZM</sub> 20N4-P16W 123331					
	2000	800 – 2000		I <sub>ZM</sub> 20N4-P20F 123572	I <sub>ZM</sub> 20N4-P20W 123332					
	800	I <sub>ZM</sub> 32B4		320 – 800	2 - 10	2 - 10, OFF		I <sub>ZM</sub> 32B4-P08F 124068		I <sub>ZM</sub> 32B4-P08W 123778
	1000			400 – 1000				I <sub>ZM</sub> 32B4-P10F 124069		I <sub>ZM</sub> 32B4-P10W 123779
	1250			500 – 1250				I <sub>ZM</sub> 32B4-P12F 124070		I <sub>ZM</sub> 32B4-P12W 123780
	1600			640 – 1600				I <sub>ZM</sub> 32B4-P16F 124071		I <sub>ZM</sub> 32B4-P16W 123781
	2000			800 – 2000				I <sub>ZM</sub> 32B4-P20F 124072		I <sub>ZM</sub> 32B4-P20W 123782
	2500			1000 – 2500				I <sub>ZM</sub> 32B4-P25F 124073		I <sub>ZM</sub> 32B4-P25W 123783
	3200	1280 – 3200		I <sub>ZM</sub> 32B4-P32F 124074	I <sub>ZM</sub> 32B4-P32W 123784					
85	800	I <sub>ZM</sub> 32N4	320 – 800	2 - 10	2 - 10, OFF	I <sub>ZM</sub> 32N4-P08F 124108	I <sub>ZM</sub> 32N4-P08W 123818			
	1000		400 – 1000			I <sub>ZM</sub> 32N4-P10F 124109	I <sub>ZM</sub> 32N4-P10W 123819			
	1250		500 – 1250			I <sub>ZM</sub> 32N4-P12F 124110	I <sub>ZM</sub> 32N4-P12W 123820			
	1600		640 – 1600			I <sub>ZM</sub> 32N4-P16F 124111	I <sub>ZM</sub> 32N4-P16W 123821			
	2000		800 – 2000			I <sub>ZM</sub> 32N4-P20F 124112	I <sub>ZM</sub> 32N4-P20W 123822			
	2500		1000 – 2500			I <sub>ZM</sub> 32N4-P25F 124113	I <sub>ZM</sub> 32N4-P25W 123823			
	3200		1280 – 3200			I <sub>ZM</sub> 32N4-P32F 124114	I <sub>ZM</sub> 32N4-P32W 123824			
	4000		I <sub>ZM</sub> 40			1600 – 4000	I <sub>ZM</sub> 40N4-P40F 124366	I <sub>ZM</sub> 40N4-P40W 124256		
	4000		I <sub>ZM</sub> 63			1600 – 4000	I <sub>ZM</sub> 63N4-P40F 124367	I <sub>ZM</sub> 63N4-P40W 124257		
	5000					2000 – 5000	I <sub>ZM</sub> 63N4-P50F 124368	I <sub>ZM</sub> 63N4-P50W 124258		
	6300					2520 – 6300	I <sub>ZM</sub> 63N4-P63F 124369	I <sub>ZM</sub> 63N4-P63W 124259		

WWW.TM2A.PT info@tm2a.pt

WWW.TM2A.PT info@tm2a.pt



Switching capacity $I_{cu} = I_{cs}$ kA	Rated operational current $I_n = I_u$ A	Frame size	Setting range			Fixed mounted		Withdrawable units		Std. pack
			Overload release $I_r$ A	Short-circuit releases		Part no. Article no.	Price See price list	Part no. Article no.	Price see price list	
				Delayed $I_{sd} = I_r \times \dots$	Non-delayed $I_i = I_n \times \dots$					
<b>Circuit-breaker for universal protection with power monitoring</b>										
Including main terminals at rear and control circuit terminals according to ordered options.										
100	800	I ZM32	320 – 800	2 - 10	2 - 10, OFF	<b>I ZM32H4-P08F</b> 124148		<b>I ZM32H4-P08W</b> 123858		1 off
	1000		400 – 1000			<b>I ZM32H4-P10F</b> 124149		<b>I ZM32H4-P10W</b> 123859		
	1250		500 – 1250			<b>I ZM32H4-P12F</b> 124150		<b>I ZM32H4-P12W</b> 123860		
	1600		640 – 1600			<b>I ZM32H4-P16F</b> 124151		<b>I ZM32H4-P16W</b> 123861		
	2000		800 – 2000			<b>I ZM32H4-P20F</b> 124152		<b>I ZM32H4-P20W</b> 123862		
	2500		1000 – 2500			<b>I ZM32H4-P25F</b> 124153		<b>I ZM32H4-P25W</b> 123863		
	3200		1280 – 3200			<b>I ZM32H4-P32F</b> 124154		<b>I ZM32H4-P32W</b> 123864		
	4000	I ZM40	1600 – 4000			<b>I ZM40H4-P40F</b> 124386		<b>I ZM40H4-P40W</b> 124276		
	4000	I ZM63	1600 – 4000			<b>I ZM63H4-P40F</b> 124387		<b>I ZM63H4-P40W</b> 124277		
	5000		2000 – 5000			<b>I ZM63H4-P50F</b> 124388		<b>I ZM63H4-P50W</b> 124278		
	6300		2520 – 6300			<b>I ZM63H4-P63F</b> 124389		<b>I ZM63H4-P63W</b> 124279		

info@tm2a.pt

info@tm2a.pt

WWW.TM2A.PT

WWW.TM2A.PT

Switching capacity $I_{cu} = I_{cs}$ kA	Rated operational current $I_n = I_u$ A	Setting range	Setting range			Fixed mounted		Withdrawable units		Std. pack
			Overload release $I_r$ A	Short-circuit releases		Part no. Article no.	Price See price list	Part no. Article no.	Price See price list	
				Delayed $I_{sd} = I_r \times \dots$	Non-delayed $I_i = I_n \times \dots$					
<b>I ZM32 for 1100 V</b>										
Including main terminals at rear and control circuit terminals according to ordered options.										
<b>Circuit-breakers for system protection</b>										
25	3200	1280 – 3200	–	2 - 10		<b>I ZM32S4-A32F-1100V</b> 123866		<b>I ZM32S4-A32W-1100V</b> 123750		1 off
<b>Selectively-opening circuit-breakers</b>										
25	3200	1280 – 3200	2 - 10	2 - 10, OFF		<b>I ZM32S4-V32F-1100V</b> 123867		<b>I ZM32S4-V32W-1100V</b> 123751		1 off
<b>Circuit-breaker for universal protection</b>										
25	3200	1280 – 3200	2 - 10	2 - 10, OFF		<b>I ZM32S4-U32F-1100V</b> 123868		<b>I ZM32S4-U32W-1100V</b> 123752		1 off
<b>Circuit-breaker with circuit-breaker</b>										
25	3200	1280 – 3200	2 - 10	2 - 10, OFF		<b>I ZM32S4-P32F-1100V</b> 123869		<b>I ZM32S4-P32W-1100V</b> 123753		1 off



Rated short-circuit making capacity $I_{cm}$ kA	Rated operational current $I_n = I_u$ A	Frame size	Rated short-time withstand current $t = 1\text{ s}$ $I_{cw}$ kA	Fixed mounted	Price See price list	Withdrawable units	Std. pack
				Part no. Article no.		Part no. Article no.	
Including main terminals at rear and control circuit terminals according to ordered options.							
55	800	IN20	50	<b>IN20B3-08F</b> 123424		<b>IN20B3-08W</b> 123184	1 off
		IN32	65	<b>IN32B3-08F</b> 123931		<b>IN32B3-08W</b> 123641	
		IN32	85	<b>IN32N3-08F</b> 123971		<b>IN32N3-08W</b> 123681	
	1000	IN20	50	<b>IN20B3-10F</b> 123425		<b>IN20B3-10W</b> 123185	
		IN32	65	<b>IN32B3-10F</b> 123932		<b>IN32B3-10W</b> 123642	
		IN32	85	<b>IN32N3-10F</b> 123972		<b>IN32N3-10W</b> 123682	
	1250	IN20	50	<b>IN20B3-12F</b> 123426		<b>IN20B3-12W</b> 123186	
		IN32	65	<b>IN32B3-12F</b> 123933		<b>IN32B3-12W</b> 123643	
		IN32	85	<b>IN32N3-12F</b> 123973		<b>IN32N3-12W</b> 123683	
	1600	IN20	50	<b>IN20B3-16F</b> 123427		<b>IN20B3-16W</b> 123187	
		IN32	65	<b>IN32B3-16F</b> 123934		<b>IN32B3-16W</b> 123644	
		IN32	85	<b>IN32N3-16F</b> 123974		<b>IN32N3-16W</b> 123684	
2000	IN20	50	<b>IN20B3-20F</b> 123428		<b>IN20B3-20W</b> 123188		
69	800	IN20	65	<b>IN20N3-08F</b> 123454		<b>IN20N3-08W</b> 123214	
	1000	IN20	65	<b>IN20N3-10F</b> 123455		<b>IN20N3-10W</b> 123215	
	1250	IN20	65	<b>IN20N3-12F</b> 123456		<b>IN20N3-12W</b> 123216	
	1600	IN20	65	<b>IN20N3-16F</b> 123457		<b>IN20N3-16W</b> 123217	
	2000	IN20	65	<b>IN20N3-20F</b> 123458		<b>IN20N3-20W</b> 123218	
		IN32	65	<b>IN32B3-20F</b> 123935		<b>IN32B3-20W</b> 123645	
		IN32	85	<b>IN32N3-20F</b> 123975		<b>IN32N3-20W</b> 123685	
	110	2500	IN32	65	<b>IN32B3-25F</b> 123936		<b>IN32B3-25W</b> 123646
2500		IN32	85	<b>IN32N3-25F</b> 123976		<b>IN32N3-25W</b> 123686	
3200		IN32	65	<b>IN32B3-32F</b> 123937		<b>IN32B3-32W</b> 123647	
3200		IN32	85	<b>IN32N3-32F</b> 123977		<b>IN32N3-32W</b> 123687	
138	4000	IN40	85	<b>IN40N3-40F</b> 124315		<b>IN40N3-40W</b> 124205	
		IN40	100	<b>IN40H3-40F</b> 124191		<b>IN40H3-40W</b> 124189	
		IN63	85	<b>IN63N3-40F</b> 124316		<b>IN63N3-40W</b> 124206	
		IN63	100	<b>IN63H3-40F</b> 124336		<b>IN63H3-40W</b> 124226	
210	3200	IN32	-	<b>IN32S3-32F-1100V</b> 123871		<b>IN32S3-32W-1100V</b> 123870	
217	5000	IN63	85	<b>IN63N3-50F</b> 124317		<b>IN63N3-50W</b> 124207	
	5000	IN63	100	<b>IN63H3-50F</b> 124337		<b>IN63H3-50W</b> 124227	
	6300	IN63	85	<b>IN63N3-63F</b> 124318		<b>IN63N3-63W</b> 124208	
	6300	IN63	100	<b>IN63H3-63F</b> 124338		<b>IN63H3-63W</b> 124228	





Rated short-circuit making capacity $I_{cm}$ kA	Rated operational current $I_n = I_u$ A	Frame size	Rated short-time withstand current $t = 1\text{ s}$ $I_{cw}$ kA	Fixed mounted Part no. Article no.	Price See price list	Withdrawable units Part no. Article no.  Cassette must be separately ordered.	Price See price list	Std. pack	
Including main terminals at rear and control circuit terminals according to ordered options.									
55	800	IN20	50	<b>IN20B4-08F</b> 123544		<b>IN20B4-08W</b> 123304		1 off	
		IN32	65	<b>IN32B4-08F</b> 124076		<b>IN32B4-08W</b> 123786			
		IN32	85	<b>IN32N4-08F</b> 124116		<b>IN32N4-08W</b> 123826			
	1000	IN20	50	<b>IN20B4-10F</b> 123545		<b>IN20B4-10W</b> 123305			
		IN32	65	<b>IN32B4-10F</b> 124077		<b>IN32B4-10W</b> 123787			
		IN32	85	<b>IN32N4-10F</b> 124117		<b>IN32N4-10W</b> 123827			
	1250	IN20	50	<b>IN20B4-12F</b> 123546		<b>IN20B4-12W</b> 123306			
		IN32	65	<b>IN32B4-12F</b> 124078		<b>IN32B4-12W</b> 123788			
		IN32	85	<b>IN32N4-12F</b> 124118		<b>IN32N4-12W</b> 123828			
	1600	IN20	50	<b>IN20B4-16F</b> 123547		<b>IN20B4-16W</b> 123307			
		IN32	65	<b>IN32B4-16F</b> 124079		<b>IN32B4-16W</b> 123789			
		IN32	85	<b>IN32N4-16F</b> 124119		<b>IN32N4-16W</b> 123829			
	69	2000	IN20	50	<b>IN20B4-20F</b> 123548		<b>IN20B4-20W</b> 123308		
			IN32	65	<b>IN20N4-08F</b> 123574		<b>IN20N4-08W</b> 123334		
		1000	IN20	65	<b>IN20N4-10F</b> 123575		<b>IN20N4-10W</b> 123335		
IN20			65	<b>IN20N4-12F</b> 123576		<b>IN20N4-12W</b> 123336			
1250		IN20	65	<b>IN20N4-16F</b> 123577		<b>IN20N4-16W</b> 123337			
		IN20	65	<b>IN20N4-20F</b> 123578		<b>IN20N4-20W</b> 123338			
1600		IN20	65	<b>IN32B4-20F</b> 124080		<b>IN32B4-20W</b> 123790			
		IN32	65	<b>IN32N4-20F</b> 124120		<b>IN32N4-20W</b> 123830			
110		2500	IN32	65	<b>IN32B4-25F</b> 124081		<b>IN32B4-25W</b> 123791		
			IN32	85	<b>IN32N4-25F</b> 124121		<b>IN32N4-25W</b> 123831		
	3200	IN32	65	<b>IN32B4-32F</b> 124082		<b>IN32B4-32W</b> 123792			
		IN32	85	<b>IN32N4-32F</b> 124122		<b>IN32N4-32W</b> 123832			
138	4000	IN40	85	<b>IN40N4-40F</b> 124370		<b>IN40N4-40W</b> 124260			
		IN40	100	<b>IN40H4-40F</b> 124192		<b>IN40H4-40W</b> 124190			
		IN63	85	<b>IN63N4-40F</b> 124371		<b>IN63N4-40W</b> 124261			
		IN63	100	<b>IN63H4-40F</b> 124391		<b>IN63H4-40W</b> 124281			
210	3200	IN32	-	<b>IN32S4-32F-1100V</b> 123894		<b>IN32S4-32W-1100V</b> 123872			
217	5000	IN63	85	<b>IN63N4-50F</b> 124372		<b>IN63N4-50W</b> 124262			
		IN63	100	<b>IN63H4-50F</b> 124392		<b>IN63H4-50W</b> 124282			
	6300	IN63	85	<b>IN63N4-63F</b> 124373		<b>IN63N4-63W</b> 124263			
		IN63	100	<b>IN63H4-63F</b> 124393		<b>IN63H4-63W</b> 124283			

WWW.TM2A.PT info@tm2a.pt

WWW.TM2A.PT info@tm2a.pt

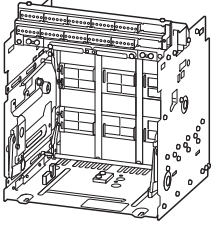
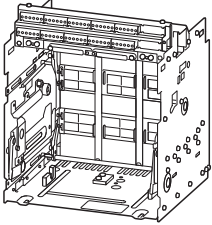

	Rated operational current $I_n$ A	For use with	3 pole  <b>Part no.</b> Article no.  <b>Part no. suffix</b> "+IZM..." Article no. for ordering with basic device	<b>Price</b> See price list	4 pole  <b>Part no.</b> Article no.  <b>Part no. suffix</b> "+IZM..." Article no. for ordering with basic device	<b>Price</b> See price list	Std. pack
<b>Withdrawable units</b>							
Cassettes in combination with basic device Standard equipment: • Arc chute cover • Coding between cassette and switch • Horizontal Connection • Door seal							
	≧ 1000	IZM20...W IN20...W	<b>+IZM-CAS203-1000</b> 124147		<b>+IZM-CAS204-1000</b> 124155		1 off
	≧ 2000	IZM20...W IN20...W	<b>+IZM-CAS203-2000</b> 122065		<b>+IZM-CAS204-2000</b> 122713		
	≧ 2000	IZM32...W IN32...W	<b>+IZM-CAS323-2000</b> 122066		<b>+IZM-CAS324-2000</b> 122714		
	≧ 2500	IZM32...W IN32...W	<b>+IZM-CAS323-2500</b> 124212		<b>+IZM-CAS324-2500</b> 124229		
	2500 - 3200	IZM32...W IN32...W	<b>+IZM-CAS323-3200</b> 122067		<b>+IZM-CAS324-3200</b> 122715		
Cassettes, ordered separately Standard components fitted to separately ordered cassette: • Arc chute cover • Complete set of control circuit terminals • Coding between cassette and switch • Horizontal Connection • Door seal							
	≧ 1000	IZM20...W IN20...W	<b>IZM-CAS203-1000</b> 124107		<b>IZM-CAS204-1000</b> 124115		1 off
	≧ 2000	IZM20...W IN20...W	<b>IZM-CAS203-2000</b> 122855		<b>IZM-CAS204-2000</b> 122863		
	≧ 2000	IZM32...W IN32...W	<b>IZM-CAS323-2000</b> 122856		<b>IZM-CAS324-2000</b> 122864		
	≧ 2500	IZM32...W IN32...W	<b>IZM-CAS323-2500</b> 124123		<b>IZM-CAS324-2500</b> 124139		
	2500 - 3200	IZM32...W IN32...W	<b>IZM-CAS323-3200</b> 122857		<b>IZM-CAS324-3200</b> 122865		
	4000	IZM40...W IN40...W	<b>IZM-CAS403-4000</b> 122859		<b>IZM-CAS404-4000</b> 122867		
	4000	IZM63...W IN63...W	<b>IZM-CAS633-4000</b> 122860		<b>IZM-CAS634-4000</b> 122868		
	5000 - 6300	IZM63...W IN63...W	<b>IZM-CAS633-6300</b> 122861		<b>IZM-CAS634-6300</b> 122869		

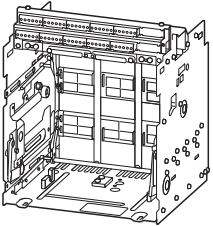
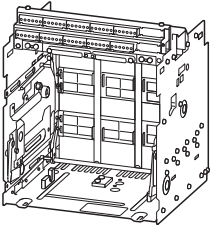

HPL18063EN

Rated operational current $I_n$ A	For use with	3 pole		4 pole		Std. pack
		Part no. Article no.	Price See price list	Part no. Article no.	Price See price list	
<b>Withdrawable units</b>						
Cassettes 1100 V in combination with basic device Standard equipment: <ul style="list-style-type: none"> <li>• Arc chute cover</li> <li>• Coding between cassette and switch</li> <li>• Horizontal Connection</li> <li>• Door seal</li> </ul>						
	3200	IZM32...W-1100V IN32...W-1100V	<b>+IZM-CAS323-3200-1100V</b> 122712		<b>+IZM-CAS324-3200-1100V</b> 122720	1 off
	Cassettes 1100 V, ordered separately Standard equipment: <ul style="list-style-type: none"> <li>• Arc chute cover</li> <li>• Complete set of control circuit terminals</li> <li>• Coding between cassette and switch</li> <li>• Horizontal Connection</li> <li>• Door seal</li> </ul>					
	3200	IZM32...W-1100V IN32...W-1100V	<b>IZM-CAS323-3200-1100V</b> 122862		<b>IZM-CAS324-3200-1100V</b> 122870	1 off
	Shutter (touch protection) When the switch is moved out of the CONNECT position, the shutters close automatically to cover the primary contacts.					
		IZM20...W IN20...W	<b>IZM-SH203</b> 122871		<b>IZM-SH204</b> 122875	1 off
		IZM20...W IN20...W	<b>+IZM-SH203</b> 122721		<b>+IZM-SH204</b> 122725	
		IZM32...W IN32...W	<b>IZM-SH323</b> 122872		<b>IZM-SH324</b> 122876	
		IZM32...W IN32...W	<b>+IZM-SH323</b> 122722		<b>+IZM-SH324</b> 122726	
		IZM40...W IN40...W	<b>IZM-SH403</b> 122873		<b>IZM-SH404</b> 122877	
		IZM40...W IN40...W	<b>+IZM-SH403</b> 122723		<b>+IZM-SH404</b> 122727	
		IZM63...W IN63...W	<b>IZM-SH633</b> 122874		<b>IZM-SH634</b> 122878	
		IZM63...W IN63...W	<b>+IZM-SH633</b> 122724		<b>+IZM-SH634</b> 122728	

WWW.TM2A.PT info@tm2a.pt

WWW.TM2A.PT info@tm2a.pt

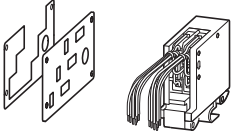
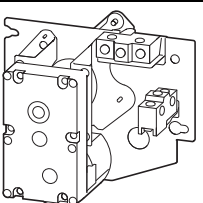

	For use with	Part no. Article no.	Price See price list	Std. pack	Notes
<b>Position signalling switches</b>					
<p>One module each with 4 changeover contacts is possible for indication of each position (extended, Test, retracted).            Only one mounting plate is required per withdrawable unit.            Each additional auxiliary contact (up to 3) requires 2 secondary terminal blocks IZM-SEC...; alternatively it can be wired directly to external terminals.            If a shutter is used, mounting is possible on the right side only.</p>					
	Four changeover contacts: One module without mounting plate	IZM20, 32, 40, 63...W IN20, 32, 40, 63...W	<b>IZM-CS4</b> 122879	1 off	-
	Four changeover contacts: One module with mounting plate		<b>IZM-CS4MB</b> 122880		
	Eight changeover contacts: Two modules with mounting plate	<b>IZM-CS8MB</b> 122881			
	Twelve changeover contacts: Three modules with mounting plate	<b>IZM-CS12MB</b> 122882			
<b>Motor drive</b>					
<p>The motor operator electrically tensions the spring-operated stored energy mechanism. For electrical remote On and Off switching, a closing release and a voltage release are required. A signaling switch labeled "Spring-operated stored energy mechanism tensioned" is included as standard.</p>					
		IZM20, 32, 40, 63... IN20, 32, 40, 63...	<b>IZM-M24DC</b> 122927	1 off	If ordered separately a secondary terminal block IZM-SEC-... is necessary for connection. Order separately if required. For terminal assignment, see page 77
			<b>+IZM-M24DC</b> 122729		
			<b>IZM-M48DC</b> 122928		
			<b>+IZM-M48DC</b> 122730		
			<b>IZM-M60DC</b> 123093		
			<b>+IZM-M60DC</b> 123079		
			<b>IZM-M110DC</b> 122929		
			<b>+IZM-M110DC</b> 122731		
			<b>IZM-M220DC</b> 122930		
			<b>+IZM-M220DC</b> 122732		
			<b>IZM-M110AC</b> 122931		
			<b>+IZM-M110AC</b> 122733		
	<b>IZM-M230AC</b> 122932				
	<b>+IZM-M230AC</b> 122734				
<b>Switching cycle counter</b>					
Counts the number of On-Off operations. Can also be used without motor operator.					
		IZM20, 32, 40, 63... IN20, 32, 40, 63...	<b>IZM-OC</b> 122933	1 off	-
			<b>+IZM-OC</b> 122735		

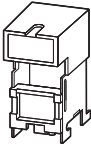
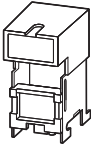
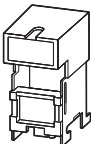
Rated control voltage U <sub>s</sub> V	For use with	Part no. Article no.	Price See price list	Std. pack	Notes
<b>Voltage releases</b>					
A closing release can be combined with a shunt release and an undervoltage release or with a second shunt release. (DF: 100%). Suited for uninterrupted operation, which ensures electrical interlocking in Off position.					
<b>Shunt release</b>					
	24 DC	IZM20, 32, 40, 63... IN20, 32,40, 63...	<b>IZM-ST24DC</b> 122934	1 off	If ordered separately a secondary terminal block IZM-SEC... is necessary for connection. Order separately if required. For terminal assignment, see page 77
	24 DC		<b>+IZM-ST24DC</b> 122736		
	48 DC		<b>IZM-ST48DC</b> 122935		
	48 DC		<b>+IZM-ST48DC</b> 122737		
	60 DC		<b>IZM-ST60DC</b> 122930		
	60 DC		<b>+IZM-ST60DC</b> 123914		
	110 - 125 DC 110 - 127 AC		<b>IZM-ST110AD</b> 122936		
	110 - 125 DC 110 - 127 AC		<b>+IZM-ST110AD</b> 122738		
	220 - 250 DC 208 - 240 AC		<b>IZM-ST230AD</b> 122937		
	220 - 250 DC 208 - 240 AC		<b>+IZM-ST230AD</b> 122739		
<b>2nd shunt release</b> Can not be combined with an undervoltage release.					
	24 DC	IZM20, 32, 40, 63... IN20, 32,40, 63...	<b>+IZM-STS24DC</b> 122740	1 off	If ordered separately a secondary terminal block IZM-SEC... is necessary for connection. Order separately if required. For terminal assignment, see page 77
	48 DC		<b>+IZM-STS48DC</b> 122741		
	60 DC		<b>+IZM-STS60DC</b> 123922		
	110 - 127 DC 110 - 127 AC		<b>+IZM-STS110AD</b> 122742		
	208 - 250 DC 208 - 250 AC		<b>+IZM-STS230AD</b> 122743		
	<b>Closing releases</b>				
	24 DC	IZM20, 32, 40, 63... IN20, 32,40, 63...	<b>IZM-SR24DC</b> 122942	1 off	If ordered separately a secondary terminal block IZM-SEC... is necessary for connection. Order separately if required. For terminal assignment, see page 77
	24 DC		<b>+IZM-SR24DC</b> 122744		
	48 DC		<b>IZM-SR48DC</b> 122943		
	48 DC		<b>+IZM-SR48DC</b> 122745		
	60 VDC		<b>IZM-SR60DC</b> 123954		
	60 VDC		<b>+IZM-SR60DC</b> 123938		
	110 - 125 DC 110 - 127 AC		<b>IZM-SR110AD</b> 122944		
	110 - 125 DC 110 - 127 AC		<b>+IZM-SR110AD</b> 122746		
	220 - 250 DC 208 - 240 AC		<b>IZM-SR230AD</b> 122945		
	220 - 250 DC 208 - 240 AC		<b>+IZM-SR230AD</b> 122747		

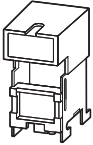

	Rated control voltage $U_s$ V	For use with	Part no. Article no.  Part no. suffix "+IZM..." Article no. for ordering with basic device	Price See price list	Std. pack	Notes
<b>Voltage releases</b>						
Undervoltage release Can not be combined with a second shunt release.						
	24 DC	IZM20, 32, 40, 63... IN20, 32,40, 63...	<b>IZM-UVR24DC</b> 122946		1 off	If ordered separately a secondary terminal block IZM-SEC-... is necessary for connection. Order separately if required. Terminal assignment page 77
	24 DC		<b>+IZM-UVR24DC</b> 122748			
	32 DC		<b>IZM-UVR32DC</b> 122947			
	32 DC		<b>+IZM-UVR32DC</b> 122749			
	48 DC		<b>IZM-UVR48DC</b> 122948			
	48 DC		<b>+IZM-UVR48DC</b> 122750			
	60 DC		<b>IZM-UVR60DC</b> 123970			
	60 DC		<b>+IZM-UVR60DC</b> 123962			
	110 - 125 DC		<b>IZM-UVR110DC</b> 122949			
	110 - 125 DC		<b>+IZM-UVR110DC</b> 122751			
	220 - 250 DC		<b>IZM-UVR220DC</b> 122950			
	220 - 250 DC		<b>+IZM-UVR220DC</b> 122752			
	110 - 127 AC		<b>IZM-UVR110AC</b> 122951			
	110 - 127 AC		<b>+IZM-UVR110AC</b> 122753			
	208 - 240 AC		<b>IZM-UVR230AC</b> 122952			
	208 - 240 AC		<b>+IZM-UVR230AC</b> 122754			
	380 - 415 AC		<b>IZM-UVR400AC</b> 122953			
	380 - 415 AC		<b>+IZM-UVR400AC</b> 122755			
	Time delay modules For combination with an undervoltage release. Delay times: 0.1 s, 0.5 s, 1.0 s, 2.0 s					
Only in combination with IZM-UVR110AC	120 AC	IZM20, 32, 40, 63... IN20, 32,40, 63...	<b>IZM-UVR-TD-120AC</b> 122956		1 off	-
Only in combination with IZM-UVR230AC	230 AC		<b>IZM-UVR-TD-230AC</b> 122957		1 off	

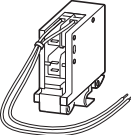
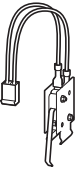
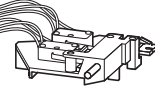
	For use with	Part no. Article no.	Price See price list	Std. pack	Notes
<b>Auxiliary contacts</b>					
Standard auxiliary switch for On-Off signaling 2 NC contacts/N/O contacts are already contained in the basic device. Maximum for IZM20, IN20: 4 N/O or NC contacts (corresponds with an additional AS22). Maximum, for IZM32, IZM40, IZM63: 6 N/O or NC contacts (corresponds with an additional AS44). 6 N/O or NC contacts are possible only when no second shunt release is installed.					
	Additionally 2 NC contact/ NO contact	IZM20, 32, 40, 63... IN20, 32, 40, 63...	<b>+IZM-AS22</b> 122758	1 off	-
	Additionally 4 NC contacts/ N/O contacts		<b>+IZM-AS44</b> 122759		
	Additionally 2 NC contact/ N/O contact		<b>IZM-AS22</b> 122958		
<b>Latch check switch</b> Latch check switch with one changeover contact.					
	-	IZM20, 32, 40, 63... IN20, 32, 40, 63...	<b>IZM-LCS-SR</b> 122974	1 off	for internal wiring with closing release
			<b>+IZM-LCS-SR</b> 122760		
			<b>IZM-LCS</b> 122959		for external keypad Indication
			<b>+IZM-LCS</b> 122761		
<b>Rated control voltage</b> $U_s$ V					
<b>Trip indication and reset options</b>					
Trip-indicating auxiliary switch (OTS) Two changeover contacts					
	-	IZM20, 32, 40, 63...	<b>IZM-OTS</b> 122960	1 off	If ordered separately a secondary terminal block IZM-SEC-... is necessary for connection. Order separately if required. Terminal assignment page 77
			<b>+IZM-OTS</b> 122762		
Automatic reset The circuit-breaker is immediately ready to close again. Not fitted with mechanical trip indicator (red pin). Can not be combined with remote reset.					
	-	IZM20, 32, 40, 63...	<b>IZM-RA</b> 122964 <b>+IZM-RA</b> 122766	1 off	-

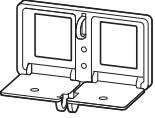

	For use with	Part no. Article no.	Price See price list	Std. pack		
<b>Locking facilities</b>						
Padlockable cover of ON/OFF buttons ON-Off pushbutton cover sealable with lead seal and lockable with padlock.						
	Metal, On pushbutton blocked	IZM20, 32, 40, 63... IN20, 32, 40, 63...	<b>+IZM-PLPC-CB-M</b> 125820	1 off		
	Plastic, On pushbutton blocked		<b>+IZM-PLPC-CB-P</b> 125649			
	Metal		<b>IZM-PLPC-M</b> 122966			
			<b>+IZM-PLPC-M</b> 122768			
	Plastic		<b>IZM-PLPC-P</b> 122965			
			<b>+IZM-PLPC-P</b> 122767			
Key locking in safe Off						
	CES installation kit, without lock cylinder and key	IZM20, 32, 40, 63... IN20, 32, 40, 63...	<b>IZM-KLP-SO-CES</b> 122968	1 off		
			<b>+IZM-KLP-SO-CES</b> 122770			
	Kirk installation kit, without lock cylinder and key		<b>IZM-KLP-SO-KIRK</b> 122969			
			<b>+IZM-KLP-SO-KIRK</b> 122771			
	Castell installation kit, without lock cylinder and key		<b>IZM-KLP-SO-CASTELL</b> 122970			
			<b>+IZM-KLP-SO-CASTELL</b> 122772			
	Ronis installation kit, without lock cylinder and key		<b>IZM-KLP-SO-RONIS</b> 122971			
			<b>+IZM-KLP-SO-RONIS</b> 122773			
Cassette key locking facility This device is fitted to the cassette and prevents a switch being switched on in its operating (Connected) position.						
	Installation on right, without lock cylinder and key		IZM20, 32, 40, 63...W IN20, 32, 40, 63...W		<b>IZM-KLP-CASS-R</b> 122972	1 off
	Installation on left, without lock cylinder and key				<b>IZM-KLP-CASS-L</b> 122973	1 off





	For use with	Part no. Article no.	Price See price list	Std. pack
<b>Locking facilities</b>				
<b>Mechanical interlock, fixed mounting</b>				
Type 2, for 2 circuit-breakers: A normal power supply (A) and an emergency mains supply (B). 1 set of cables also required.	IZM20, 32, 40, 63...F IN20, 32, 40, 63...F	<b>IZM-MIL2C-F</b> 122980		1 off
Type 31, for 3 circuit-breakers: Two normal power supplies (A, C) and an emergency network supply (B). When B in Off, A and C can be switched on. B can be switched on only when A and C are in Off. Two sets of cables required in addition.		<b>IZM-MIL31C-F</b> 122981		
Type 32, for 3 circuit-breakers: Two normal power supplies (A, C) and a coupling (B). Any one or two circuit-breakers can be closed at the same time. Three sets of cables are required in addition.		<b>IZM-MIL32C-F</b> 122982		
Type 33, for 3 circuit-breakers: Three power supplies (A, B, C), normal or emergency network. Only one of the three circuit-breakers can be switched on at any one time. Three sets of cables are required in addition.		<b>IZM-MIL33C-F</b> 122983		
<b>Mechanical interlock, withdrawable units</b>				
Type 2, for 2 circuit-breakers: A normal power supply (A) and an emergency network supply (B). 1 set of cables also required.	IZM20, 32, 40, 63...W IN20, 32, 40, 63...W	<b>IZM-MIL2C-W</b> 122985		1 off
Type 31, for 3 circuit-breakers: Two normal power supplies (A, C) and an emergency network supply (B). When B in Off, A and C can be switched on. B can be switched on only when A and C are in Off. Two sets of cables required in addition.		<b>IZM-MIL31C-W</b> 122986		
Type 32, for 3 circuit-breakers: Two normal power supplies (A, C) and a coupling (B). Any one or two circuit-breakers can be closed at the same time. Three sets of cables are required in addition.		<b>IZM-MIL32C-W</b> 122987		
Type 33, for 3 circuit-breakers: Three power supplies (A, B, C), normal or emergency network. Only one of the three circuit-breakers can be switched on at any one time. Three sets of cables are required in addition.		<b>IZM-MIL33C-W</b> 122988		
<b>Cable sets for mechanical interlock</b>				
Depending on the type of interlock, a particular number of cable connectors is required. With the flexible cable connectors, various different switch arrangements can be implemented. Each set contains two cables.				
1520 mm long	IZM20, 32, 40, 63... IN20, 32, 40, 63...	<b>IZM-MIL-CAB1520</b> 122975		1 off
1830 mm long		<b>IZM-MIL-CAB1830</b> 122976		
2440 mm long		<b>IZM-MIL-CAB2440</b> 122977		
3050 mm long		<b>IZM-MIL-CAB3050</b> 122978		

**Instruction**

For possible switching states, → Page 77



	Rated control voltage U <sub>s</sub> V	For use with	Part no. Article no.  Part no. suffix "+IZM..." Article no. for ordering with basic device	Price See price list	Std. pack	Notes
<b>Options and accessories for electronic releases</b>						
One of the following overcurrent releases (DT = Digitrip) is supplied as standard with every IZM circuit-breaker:						
<ul style="list-style-type: none"> <li>• Type A: DT-520LI</li> <li>• Type V: DT-520LSI</li> <li>• Type U: DT-520MC</li> <li>• Type P: DT-1150</li> </ul>						
Trip unit for Type A circuit-breaker (equipped with Digitrip 520LI)						
System protection		IZM...-A... (Digitrip 520LI)	<b>IZM-DTA</b> 122774		1 off	
Trip unit for Type V circuit-breaker (equipped with Digitrip 520LSI)						
Selectivity protection		IZM...-V... (Digitrip 520MC)	<b>IZM-DTV</b> 122775		1 off	
Add-on function for Type V circuit-breaker						
Ground fault protection	–	IZM...-V... (Digitrip 520LSI)	<b>+IZM-DTV-EP</b> 122776		1 off	–
Trip unit for Type U circuit-breaker (equipped with Digitrip 520M)						
Universal protection Type U contains the following as standard:		IZM...-U... (Digitrip 520LSI)	<b>IZM-DTU</b> 122777		1 off	
<ul style="list-style-type: none"> <li>• Communication interface</li> <li>• Overload alarm with signalling contact</li> <li>• Prepared for external 24/48 V DC supply (e.g. for display)</li> <li>• (A14 = +24 VDC/A15 = -24 VDC)</li> </ul>						
Only one of the following three options can be selected at a time:						
Ground-fault protection, ground-fault alarm or overload alarm.						
For fieldbus communications an interface module IZM-PMINT/IZM-MMINT is required in addition.						
	240 AC	IZM...-U... (Digitrip 520MC)	<b>+IZM-DTU-HA2</b> 122779		1 off	Not in combination with ground-fault protection or alarm
With ground-fault protection instead of overload alarm, prepared for 24/48 V DC.	24/48 DC		<b>+IZM-DTU-EP</b> 122780		1 off	Not in combination with overload or ground-fault alarm
With ground-fault protection instead of overload alarm, prepared for 240 V AC.	240 AC		<b>+IZM-DTU-EP2</b> 122782		1 off	Not in combination with overload or ground-fault alarm
With ground-fault alarm instead of overload alarm, prepared for 24/48 V DC.	24/48 DC		<b>+IZM-DTU-EA</b> 122783		1 off	Not in combination with overload alarm or ground-fault protection
With ground-fault alarm instead of overload alarm, prepared for 240 V AC.	240 AC		<b>+IZM-DTU-EA2</b> 122785		1 off	Not in combination with overload alarm or ground-fault protection
Through a simple, reliable means, the ARMS (Arcflash Reduction Maintenance System™) function can reduce the Off time for enhanced safety. Must be specifically activated.	–		<b>+IZM-DTU-ARMS</b> 122791		1 off	–
NC-reduced: The Type U electronics are supplied without communications interface.	–		<b>+IZM-DTU-NC</b> 122790		1 off	Cannot be combined with: • IZM-DTU-NPC • IZM-DTU-ARMS
NPC-reduced: The Type U electronics are supplied without communications interface and without interface to the external supply.	–		<b>+IZM-DTU-NPC</b> 122788		1 off	Only in combination with IZM-DTU-EP. Can not be combined with other options.

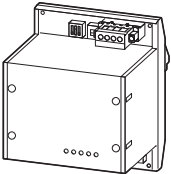

	Rated control voltage U <sub>s</sub> V	For use with	Part no. Article no.  Part no. suffix "+IZM..." Article no. for ordering with basic device	Price See price list	Std. pack
<b>Options and accessories for electronic releases</b>					
Trip unit for Type P circuit-breakers					
Power measurement		IZM...-P... (Digitrip 1150)	<b>IZM-DTP</b> 122894		1 off
Type P contains the following as standard:					
<ul style="list-style-type: none"> <li>• Power measurement</li> <li>• Communication interface</li> <li>• Overload alarm with signalling contact</li> <li>• Prepared for external 24/48 V DC supply (e.g. for display)</li> <li>• (A14 = +24 VDC/A15 = -24 VDC).</li> </ul>					
Ground-fault protection and alarm are combined in a single option (IZM-DTP-EPA), which can be combined with overload alarm.					
For field bus communications a corresponding interface module IZM-PMINT/IZM-MMINT is required in addition.					
Add-on function for Type P circuit-breaker					
With overload alarm, prepared for external 240 V AC supply instead of 24/48 V DC.	240 AC	IZM...-P... (Digitrip 1150)	<b>+IZM-DTP2</b> 122906		1 off
With additional ground-fault protection and alarm, prepared for 24/48 V DC.	24/48 DC		<b>+IZM-DTP-EPA</b> 122915		
With additional ground-fault protection and alarm, prepared for 240 V AC.	240 AC		<b>+IZM-DTP-EPA2</b> 122938		
Through a simple, reliable means, the ARMS (Arcflash Reduction Maintenance System™) function can reduce the Off time for enhanced safety. Must be specifically activated.	–		<b>+IZM-DTP-ARMS</b> 122939		
Voltage tap on power supply at bottom: Internally, voltage is tapped at the lower (instead of the upper) contacts. Voltage tapping is relevant for power monitoring.	–		<b>+IZM-DTP-PFBT</b> 122990		
TripLink transmits all protection parameters from one switch to the other, for example when replacing a device for maintenance.	–		<b>IZM-DTP-TL</b> 122989		
Digital relay module for circuit-breakers (Type P) power measurement			<b>IZM-DTP-RM</b> 101534		

	Rated control voltage U <sub>s</sub> V	For use with	Part no. Article no.	Price See price list	Std. pack
<b>Communication modules</b>					
Fieldbus interfaces for Digitrip IZM...-U... and IZM...-P...					
	The PROFIBUS communication interface is mounted on top-hat rails.	IZM...-U... (Digitrip 520MC) IZM...-P... (Digitrip 1150)	<b>IZM-PMINT</b> 124235		1 off
	The Modbus communication interface is mounted on top-hat rails.		<b>IZM-MMINT</b> 124236		1 off
Hand held test unit for Digitrip					
	IZM...-A... (Digitrip 520LI) IZM...-V... (Digitrip 520LSI) IZM...-U... (Digitrip 520M)	Testing device for IZM26	<b>IZM-SIM-KIT</b> 101535		1 off



Rated operational current $I_n$ A	For use with	3 pole	Price	4 pole	Price	Std. pack
		Part no. Article no.	See price list	Part no. Article no.	See price list	
		<b>Part no. suffix "+IZM..."</b> Article no. for ordering with basic device		<b>Part no. suffix "+IZM..."</b> Article no. for ordering with basic device		
<b>Rating plug sensor and current transformer</b>						
This combination is required when a circuit-breaker's rated operational current is to be reduced.						
	200	IZM20... 800 A $\leq I_u \leq 2000$ A	<b>IZM-RP203-200</b> 122995		<b>IZM-RP204-200</b> 123026	1 off
	200	IZM20... 800 A $\leq I_u \leq 2000$ A	<b>+IZM-RP203-200</b> 122793		<b>+IZM-RP204-200</b> 122824	
	250	IZM20... 800 A $\leq I_u \leq 2000$ A	<b>IZM-RP203-250</b> 122996		<b>IZM-RP204-250</b> 123027	
	250	IZM20... 800 A $\leq I_u \leq 2000$ A	<b>+IZM-RP203-250</b> 122794		<b>+IZM-RP204-250</b> 122825	
	300	IZM20... 800 A $\leq I_u \leq 2000$ A	<b>IZM-RP203-300</b> 122997		<b>IZM-RP204-300</b> 123028	
	300	IZM20... 800 A $\leq I_u \leq 2000$ A	<b>+IZM-RP203-300</b> 122795		<b>+IZM-RP204-300</b> 122826	
	400	IZM20... 800 A $\leq I_u \leq 2000$ A	<b>IZM-RP203-400</b> 122998		<b>IZM-RP204-400</b> 123029	
	400	IZM20... 800 A $\leq I_u \leq 2000$ A	<b>+IZM-RP203-400</b> 122796		<b>+IZM-RP204-400</b> 122827	
	630	IZM20... 800 A $\leq I_u \leq 2000$ A	<b>IZM-RP203-630</b> 122999		<b>IZM-RP204-630</b> 123030	
	630	IZM20... 800 A $\leq I_u \leq 2000$ A	<b>+IZM-RP203-630</b> 122797		<b>+IZM-RP204-630</b> 122828	
	800	IZM20... 800 A $\leq I_u \leq 2000$ A	<b>IZM-RP203-800</b> 123000		<b>IZM-RP204-800</b> 123031	
	800	IZM20... 800 A $\leq I_u \leq 2000$ A	<b>+IZM-RP203-800</b> 122798		<b>+IZM-RP204-800</b> 122829	
	1000	IZM20... 1000 A $\leq I_u \leq 2000$ A	<b>IZM-RP203-1000</b> 123001		<b>IZM-RP204-1000</b> 123032	
	1000	IZM20... 1000 A $\leq I_u \leq 2000$ A	<b>+IZM-RP203-1000</b> 122799		<b>+IZM-RP204-1000</b> 122830	
	1250	IZM20... 1250 A $\leq I_u \leq 2000$ A	<b>IZM-RP203-1250</b> 123002		<b>IZM-RP204-1250</b> 123033	
	1250	IZM20... 1250 A $\leq I_u \leq 2000$ A	<b>+IZM-RP203-1250</b> 122800		<b>+IZM-RP204-1250</b> 122831	
	1600	IZM20... 1600 A $\leq I_u \leq 2000$ A	<b>IZM-RP203-1600</b> 123003		<b>IZM-RP204-1600</b> 123034	
	1600	IZM20... 1600 A $\leq I_u \leq 2000$ A	<b>+IZM-RP203-1600</b> 122801		<b>+IZM-RP204-1600</b> 122832	
	2000	IZM20... 2000 A	<b>IZM-RP203-2000</b> 123004		<b>IZM-RP204-2000</b> 123035	
	200	IZM32... 800 A $\leq I_u \leq 3200$ A	<b>IZM-RP323-200</b> 123005		<b>IZM-RP324-200</b> 123036	
	200	IZM32... 800 A $\leq I_u \leq 3200$ A	<b>+IZM-RP323-200</b> 122803		<b>+IZM-RP324-200</b> 122834	
	250	IZM32... 800 A $\leq I_u \leq 3200$ A	<b>IZM-RP323-250</b> 123006		<b>IZM-RP324-250</b> 123037	
	250	IZM32... 800 A $\leq I_u \leq 3200$ A	<b>+IZM-RP323-250</b> 122804		<b>+IZM-RP324-250</b> 122835	
	300	IZM32... 800 A $\leq I_u \leq 3200$ A	<b>IZM-RP323-300</b> 123007		<b>IZM-RP324-300</b> 123038	
	300	IZM32... 800 A $\leq I_u \leq 3200$ A	<b>+IZM-RP323-300</b> 122805		<b>+IZM-RP324-300</b> 122836	
	400	IZM32... 800 A $\leq I_u \leq 3200$ A	<b>IZM-RP323-400</b> 123008		<b>IZM-RP324-400</b> 123039	
	400	IZM32... 800 A $\leq I_u \leq 3200$ A	<b>+IZM-RP323-400</b> 122806		<b>+IZM-RP324-400</b> 122837	
	630	IZM32... 800 A $\leq I_u \leq 3200$ A	<b>IZM-RP323-630</b> 123009		<b>IZM-RP324-630</b> 123040	
	630	IZM32... 800 A $\leq I_u \leq 3200$ A	<b>+IZM-RP323-630</b> 122807		<b>+IZM-RP324-630</b> 122838	
	800	IZM32... 800 A $\leq I_u \leq 3200$ A	<b>IZM-RP323-800</b> 123010		<b>IZM-RP324-800</b> 123041	
	800	IZM32... 800 A $\leq I_u \leq 3200$ A	<b>+IZM-RP323-800</b> 122808		<b>+IZM-RP324-800</b> 122839	

Rated operational current $I_n$ A	For use with	3 pole	Price See price list	4 pole	Price See price list	Std. pack
		<b>Part no.</b> Article no.		<b>Part no.</b> Article no.		
		<b>Part no. suffix "+IZM..."</b> Article no. for ordering with basic device		<b>Part no. suffix "+IZM..."</b> Article no. for ordering with basic device		
<b>Rating plug sensor and current transformer</b>						
This combination is required when a circuit-breaker's rated operational current is to be reduced.						
	1000	IZM32... 1000 A $\leq I_u \leq 3200$ A	<b>IZM-RP323-1000</b> 123011	<b>IZM-RP324-1000</b> 123042		1 off
	1000	IZM32... 1000 A $\leq I_u \leq 3200$ A	<b>+IZM-RP323-1000</b> 122809	<b>+IZM-RP324-1000</b> 122840		
	1250	IZM32... 1250 A $\leq I_u \leq 3200$ A	<b>IZM-RP323-1250</b> 123012	<b>IZM-RP324-1250</b> 123043		
	1250	IZM32... 1250 A $\leq I_u \leq 3200$ A	<b>+IZM-RP323-1250</b> 122810	<b>+IZM-RP324-1250</b> 122841		
	1600	IZM32... 1600 A $\leq I_u \leq 3200$ A	<b>IZM-RP323-1600</b> 123013	<b>IZM-RP324-1600</b> 123044		
	1600	IZM32... 1600 A $\leq I_u \leq 3200$ A	<b>+IZM-RP323-1600</b> 122811	<b>+IZM-RP324-1600</b> 122842		
	2000	IZM32... 2000 A $\leq I_u \leq 3200$ A	<b>IZM-RP323-2000</b> 123014	<b>IZM-RP324-2000</b> 123045		
	2000	IZM32... 2000 A $\leq I_u \leq 3200$ A	<b>+IZM-RP323-2000</b> 122812	<b>+IZM-RP324-2000</b> 122843		
	2500	IZM32... 2500 A $\leq I_u \leq 3200$ A	<b>IZM-RP323-2500</b> 123015	<b>IZM-RP324-2500</b> 123046		
	2500	IZM32... 2500 A $\leq I_u \leq 3200$ A	<b>+IZM-RP323-2500</b> 122813	<b>+IZM-RP324-2500</b> 122844		
	3200	IZM32... 3200 A	<b>IZM-RP323-3200</b> 123016	<b>IZM-RP324-3200</b> 123047		
	2000	IZM40... 2000 A $\leq I_u \leq 4000$ A	<b>IZM-RP403-2000</b> 123017	<b>IZM-RP404-2000</b> 123048		
	2000	IZM40... 2000 A $\leq I_u \leq 4000$ A	<b>+IZM-RP403-2000</b> 122815	<b>+IZM-RP404-2000</b> 122846		
	2500	IZM40... 2500 A $\leq I_u \leq 4000$ A	<b>IZM-RP403-2500</b> 123018	<b>IZM-RP404-2500</b> 123049		
	2500	IZM40... 2500 A $\leq I_u \leq 4000$ A	<b>+IZM-RP403-2500</b> 122816	<b>+IZM-RP404-2500</b> 122847		
	3200	IZM40... 3200 A $\leq I_u \leq 4000$ A	<b>IZM-RP403-3200</b> 123019	<b>IZM-RP404-3200</b> 123050		
	3200	IZM40... 3200 A $\leq I_u \leq 4000$ A	<b>+IZM-RP403-3200</b> 122817	<b>+IZM-RP404-3200</b> 122848		
	4000	IZM40... 4000 A	<b>IZM-RP403-4000</b> 122802	<b>IZM-RP404-4000</b> 122814		
	2000	IZM63... 4000 A	<b>IZM-RP633-2000</b> 124244	<b>IZM-RP634-2000</b> 124321		
	2000	IZM63... 4000 A	<b>+IZM-RP633-2000</b> 124319	<b>+IZM-RP634-2000</b> 124264		
	2500	IZM63... 4000 A $\leq I_u \leq 5000$ A	<b>IZM-RP633-2500</b> 124320	<b>IZM-RP634-2500</b> 124211		
	2500	IZM63... 4000 A $\leq I_u \leq 5000$ A	<b>+IZM-RP633-2500</b> 124209	<b>+IZM-RP634-2500</b> 124299		
	3200	IZM63... 4000 A $\leq I_u \leq 6300$ A	<b>IZM-RP633-3200</b> 124210	<b>IZM-RP634-3200</b> 124322		
	3200	IZM63... 4000 A $\leq I_u \leq 6300$ A	<b>+IZM-RP633-3200</b> 124374	<b>+IZM-RP634-3200</b> 124354		
	4000	IZM63... 4000 A $\leq I_u \leq 6300$ A	<b>IZM-RP633-4000</b> 123023	<b>IZM-RP634-4000</b> 123054		
	4000	IZM63... 4000 A $\leq I_u \leq 6300$ A	<b>+IZM-RP633-4000</b> 122821	<b>+IZM-RP634-4000</b> 122852		
	5000	IZM63... 5000 A $\leq I_u \leq 6300$ A	<b>IZM-RP633-5000</b> 123024	<b>IZM-RP634-5000</b> 123055		
	5000	IZM63... 5000 A $\leq I_u \leq 6300$ A	<b>+IZM-RP633-5000</b> 122822	<b>+IZM-RP634-5000</b> 122853		
	6300	IZM63... 6300 A	<b>IZM-RP633-6300</b> 123025	<b>IZM-RP634-6300</b> 123056		





WWW.TM2A.PT info@tm2a.pt

WWW.TM2A.PT info@tm2a.pt

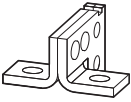
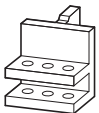

Rated operational current $I_n$ A	For use with	Part no. Article no.	Price See price list	Std. pack
<b>Current sensors for Neutral conductor</b>				
For neutral conductor protection or comprehensive ground-fault protection of 3 pole circuit-breakers an external converter is required for current monitoring in the neutral conductor.				
200	IZM20... IZM32...	<b>IZM-CTN-200</b> 123057		1 off
250	IZM20... IZM32...	<b>IZM-CTN-250</b> 123058		
300	IZM20... IZM32...	<b>IZM-CTN-300</b> 123059		
400	IZM20... IZM32...	<b>IZM-CTN-400</b> 123060		
630	IZM20... IZM32...	<b>IZM-CTN-630</b> 123061		
800	IZM20... IZM32...	<b>IZM-CTN-800</b> 123062		
1000	IZM20... IZM32...	<b>IZM-CTN-1000</b> 123063		
1250	IZM20... IZM32...	<b>IZM-CTN-1250</b> 123064		
1600	IZM20... IZM32...	<b>IZM-CTN-1600</b> 123065		
2000	IZM20... IZM32...	<b>IZM-CTN-2000</b> 123066		
2500	IZM32...	<b>IZM-CTN-2500</b> 123067		
3200	IZM32...	<b>IZM-CTN-3200</b> 123068		
4000	IZM40... IZM63...	<b>IZM-CTN-4000</b> 123069		
5000	IZM63...	<b>IZM-CTN-5000</b> 123070		
6300	IZM63...	<b>IZM-CTN-6300</b> 123071		





	Rated operational current $I_n$ A	Rated ultimate short-circuit breaking capacity $I_{cu}$ kA	Pole	For use with	Part no. Article no.	Price See price list	Std. pack
<b>Main terminal kits</b>							
Each basic device of the IZM26 series is supplied with horizontal connections as standard. <sup>1)</sup>							
Vertical connections for fixed mounting or cassette							
	≤ 2000	≤ 65	3	IZM20... IN20...	<b>IZM-TV203N-2000</b> 123072		1 off
	4000	≤ 100	3	IZM40... IN40...	<b>IZM-TV403H-4000</b> 123081		
	≤ 2000	≤ 65	4	IZM20... IN20...	<b>IZM-TV204N-2000</b> 123086		
	4000	≤ 100	4	IZM40... IN40...	<b>IZM-TV404H-4000</b> 123095		
	≤ 1600	≤ 65	3	IZM32... IN32...	<b>IZM-TV323B-1600</b> 123074		
	≤ 2000	≤ 100	3	IZM32B...20 IN32B...20 IZM32H..., IN32H...	<b>IZM-TV323H-2000</b> 123075		
	2500 - 3200	100	3	IZM32... IN32...	<b>IZM-TV323H-3200</b> 123077		
	≤ 1600	≤ 65	4	IZM32... IN32...	<b>IZM-TV324B-1600</b> 123088		
	≤ 2000	≤ 100	4	IZM32B...20 IN32B...20 IZM32H..., IN32H...	<b>IZM-TV324H-2000</b> 123089		
	2500 - 3200	100	4	IZM32... IN32...	<b>IZM-TV324H-3200</b> 123091		
	4000	100	3	IZM63... IN63...	<b>IZM-TV633H-4000</b> 123082		
	5000 - 6300	100	3	IZM63... IN63...	<b>IZM-TV633H-6300</b> 123084		
	4000	100	4	IZM63... IN63...	<b>IZM-TV634H-4000</b> 123096		
	5000 - 6300	100	4	IZM63... IN63...	<b>IZM-TV634H-6300</b> 123098		
<b>Front connections for fixed mounting or cassette</b>							
	≤ 1250	≤ 65	3	IZM20... IN20...	<b>IZM-TF203N-1250</b> 123100		1 off
	≤ 1250	≤ 65	4	IZM20... IN20...	<b>IZM-TF204N-1250</b> 123108		
	1600 - 2000	≤ 65	3	IZM20... IN20...	<b>IZM-TF203N-2000</b> 123102		
	4000	≤ 100	3	IZM40... IN40... IZM63N(H)3...40 <sup>2)</sup>	<b>IZM-TF403H-4000</b> 123107		
	≤ 2000	≤ 65	4	IZM20... IN20...	<b>IZM-TF204N-2000</b> 123110		
	4000	≤ 100	4	IZM40... IN40... IZM63N(H)4...40 <sup>2)</sup>	<b>IZM-TF404H-4000</b> 123115		
	≤ 1250	≤ 65	3	IZM32B... IN32B...	<b>IZM-TF323B-1250</b> 124225		
	1600 - 2500	≤ 65	3	IZM32B... IN32B...	<b>IZM-TF323B-2500</b> 123104		
	≤ 3200	≤ 100	3	IZM32B...32... IN32B...32... IZM32N..., IN32N... IZM32H..., IN32H... IZM63N(H)3...50 (63) <sup>2)</sup>	<b>IZM-TF323H-3200</b> 123105		
	≤ 1250	≤ 65	4	IZM32B... IN32B...	<b>IZM-TF324B-1250</b> 124280		
	≤ 2500	≤ 65	4	IZM32B... IN32B...	<b>IZM-TF324B-2500</b> 123112		
	≤ 3200	≤ 100	4	IZM32B...32... IN32B...32... IZM32N..., IN32N... IZM32H..., IN32H... IZM63N(H)4...50 (63) <sup>2)</sup>	<b>IZM-TF324H-3200</b> 123113		

Notes

- <sup>1)</sup> For 3 pole switches: 6 off; for 4 pole switches: 8 off.  
IZM40: For 3 pole switches: 12 off, for 4 pole switches: 16 off
- <sup>2)</sup> For use with this type, you must order the corresponding article twice.

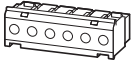
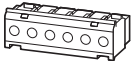
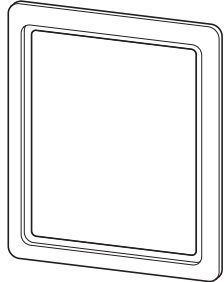

	Rated control voltage $U_s$ V	For use with	Part no. Article no.	Price See price list	Std. pack
<b>General accessories</b>					
Control circuit terminal, 2 blocks Two terminal blocks, each for six control circuit terminals, complete with labels; AMP tool (AMP No. 305183) and internal wiring.	–	IZM20, 32, 40, 63... IN20, 32, 40, 63...	<b>IZM-SEC-TB2</b> 123116		1 off
					
Control circuit terminal, 15 blocks 15 terminal blocks, each for six control circuit terminals, with labels. Order wiring set separately.	–	IZM20, 32, 40, 63... IN20, 32, 40, 63...	<b>IZM-SEC-TB15</b> 123117		1 off
					
Wiring set for control circuit terminals Wiring material (built into switch), 90 wires for 15 terminal blocks.	–	IZM20, 32, 40, 63... IN20, 32, 40, 63...	<b>IZM-SEC-WR90</b> 122789		1 off
Spare door escutcheon, IP41 Spare part; the door escutcheon is supplied as standard with the basic unit or cassette.	–	IZM20, 32, 40, 63... IN20, 32, 40, 63...	<b>IZM-DEG</b> 122925		1 off
					
Protective cover, IP55	–	IZM20, 32, 40, 63... IN20, 32, 40, 63...	<b>IZM-DC</b> 122926		1 off
Lifting yoke for lifting Consists of two specially shaped steel hooks that engage in the molded lifting handles in the basic unit of the switch closure.	3	IZM20... IN20...	<b>IZM203-8651C91G09</b> 124237		1 off
	3	IZM32... IN32...	<b>IZM323-8651C91G02</b> 124239		
	3	IZM40... IN40...	<b>IZM403-2A10886G03</b> 124241		
	3	IZM63... IN63...	<b>IZM633-8651C91G05</b> 124243		
	4	IZM20... IN20...	<b>IZM204-8651C91G10</b> 124238		
	4	IZM32... IN32...	<b>IZM324-8651C91G07</b> 124240		
	4	IZM40... IN40...	<b>IZM404-2A10886G07</b> 124242		
	4	IZM63... IN63...	<b>IZM634-8651C91G08</b> 124245		
Trolley Allows lifting of the switch basic unit in combination with the lifting yoke.	–	IZM20, 32, 40, 63... IN20, 32, 40, 63...	<b>IZM-6727D63H20</b> 124246		1 off
					



I ZM26

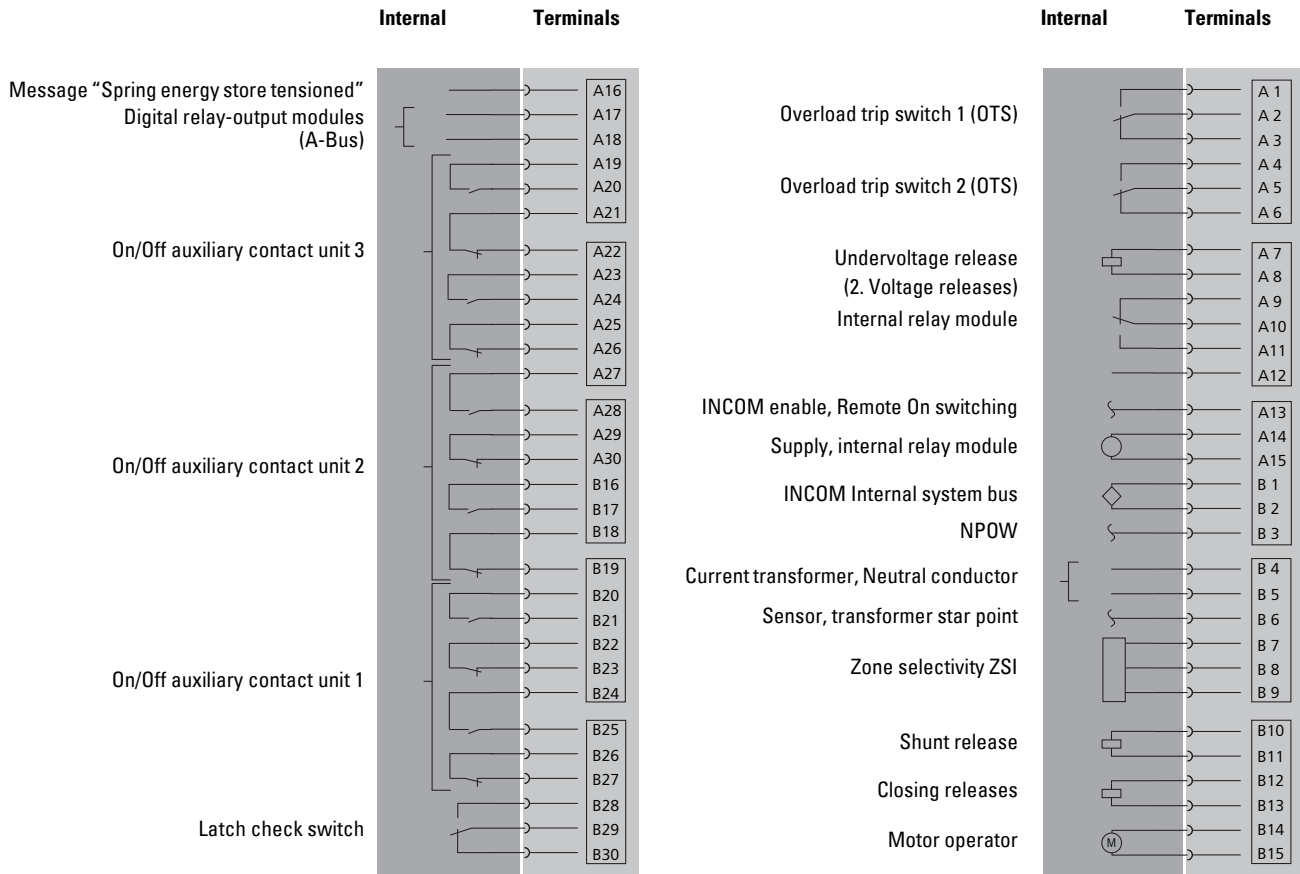

Switching states at mechanical interlock

Mechanical interlock	Possible switching states		
	Switch A	Switch B	Switch C
Part no. 2	0	0	
	1	0	
	0	1	
Part no. 31	Switch A	Switch B	Switch C
	0	0	0
	1	0	0
	0	1	0
	0	0	1
Part no. 32	Switch A	Switch B	Switch C
	0	0	0
	1	0	0
	0	1	0
	0	0	1
	1	1	0
Part no. 33	Switch A	Switch B	Switch C
	0	1	1
	1	0	1
	0	0	1

WWW.TM2A.PT info@tm2a.pt

WWW.TM2A.PT info@tm2a.pt

WWW.TM2A.PT



**IZM26...A...Tripping characteristics for selective protection**

Overload protection (L) and non-delayed short-circuit protection (I)

L-Protection: Adjustable

See Notes 1, 2, 3.

I-protection: Adjustable

See Notes 3, 4, 5, 6, 7.

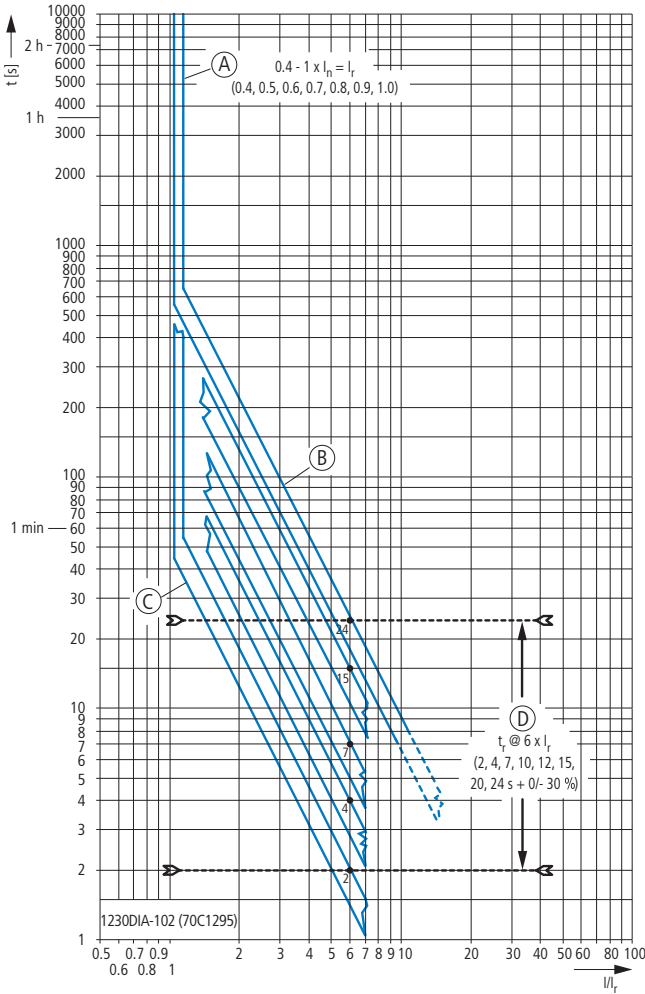

- A Set values for overload protection
- B Maximum total opening delay
- C Minimum total opening delay
- D Set values for long delay

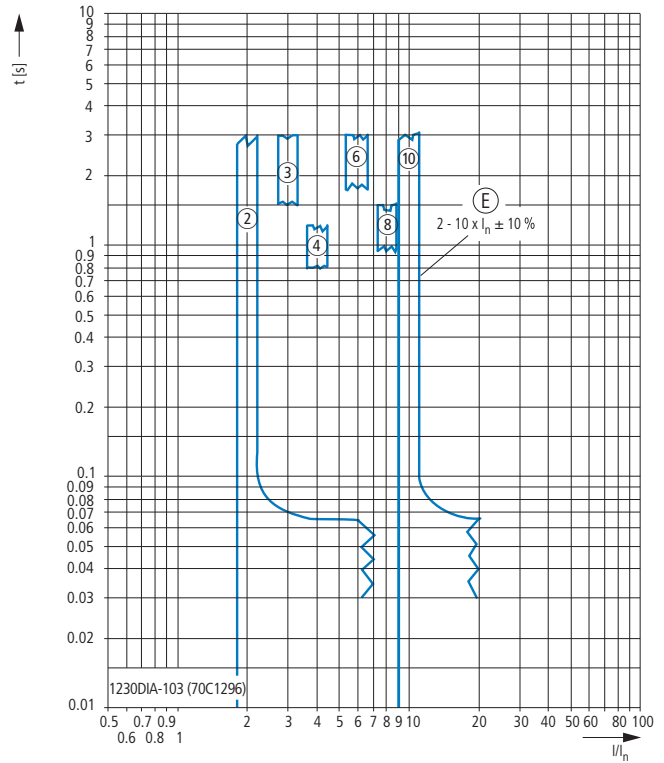

E Set values for short-time delayed short-circuit protection

I-protection: For high short-circuit currents  
See Notes 3, 4, 5, 6, 7.

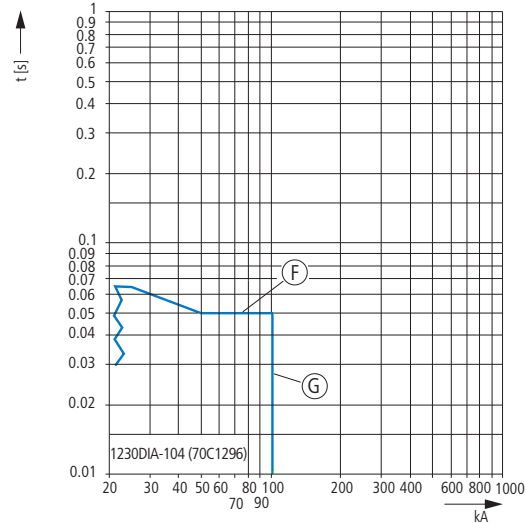

- F Set values for short-time delayed short-circuit protection with flat characteristic curve
- G The end of the characteristic curve is determined by the type of application and the switching capacity of the selected switch.

**IzM26...V(U)... Tripping characteristics for selectivity protection and universal protection**

Overload protection (L) and short-time delayed short-circuit protection (S)

L-Protection:  $I^2t$  characteristic curve and S protection: flat characteristic curve  
See Notes 1, 3, 4, 6, 7, 8, 9, 10.

S protection:  $I^2t$  characteristic curve  
See Notes 1, 3, 4, 6, 7, 8, 9, 10.

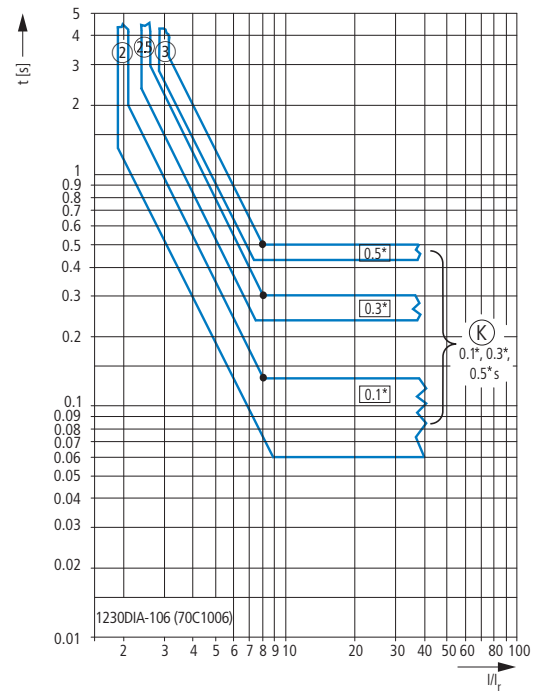
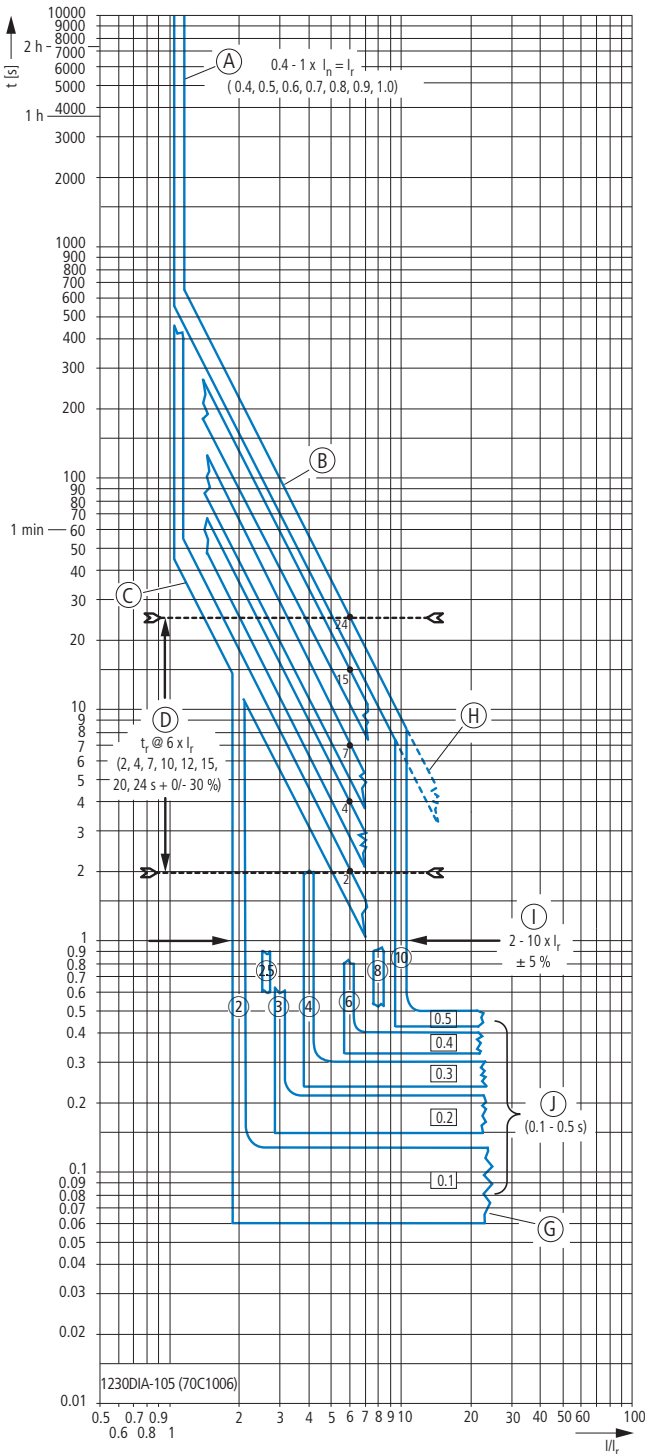

K Set values for ground fault protection

- A Set values for overload protection
- B Maximum total opening delay
- C Minimum total opening delay
- D Set values for long delay
- G The end of the characteristic curve is determined by the type of application and the switching capacity of the selected switch.
- H The characteristic curve for the overload release can extend up to the M1 set value.
- I Available set values for short-time delayed short-circuit protection  $I_{sd}$
- J Short-circuit release for very high currents

WWW.TM2A.PT info@tm2a.pt

WWW.TM2A.PT info@tm2a.pt



**IZM26...V(U)... Tripping characteristics for selectivity protection and universal protection**

Non-delayed short-circuit protection (I)

I-protection: Adjustable

See Notes 4, 5, 6, 7, 11, 12.

I-protection: For high short-circuit currents

See Notes 4, 5, 6, 7, 11, 12.

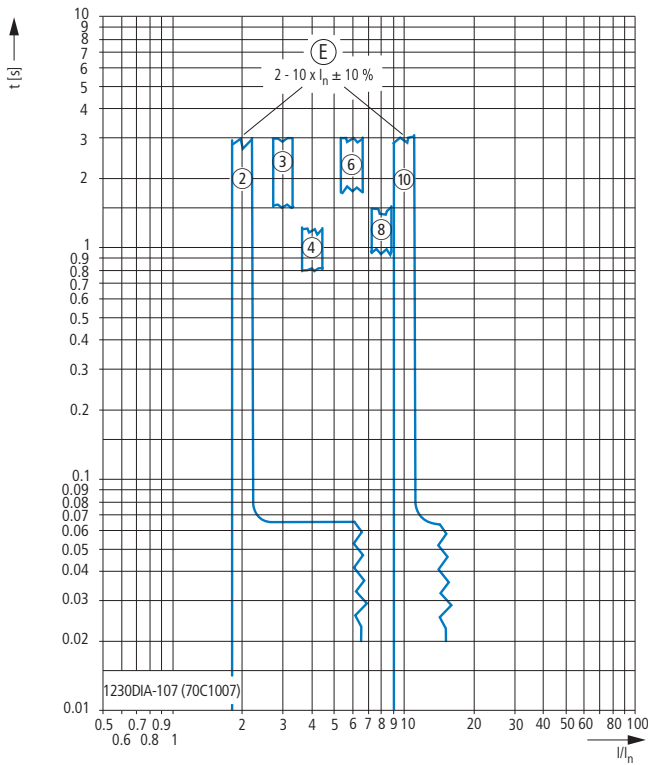

E Set values for short-time delayed short-circuit protection

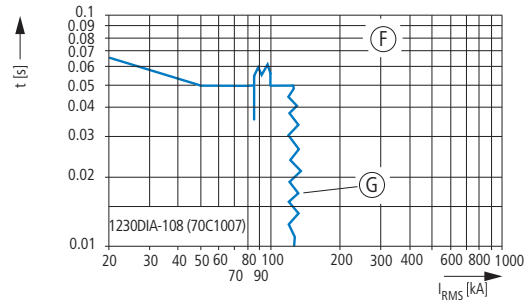

F Set values for short-time delayed short-circuit protection with flat characteristic curve

G The end of the characteristic curve is determined by the type of application and the switching capacity of the selected switch.

**IZM26...V(U)... Option ground-fault protection +IZM-DTV(U)-E...**

G: Ground fault protection, flat characteristic curve

See Notes 4, 6, 13, 14, 15, 16, 17.

G: Ground fault protection, I<sup>2</sup>t-Characteristic curve

See Notes 4, 6, 13, 14, 15, 16, 17.

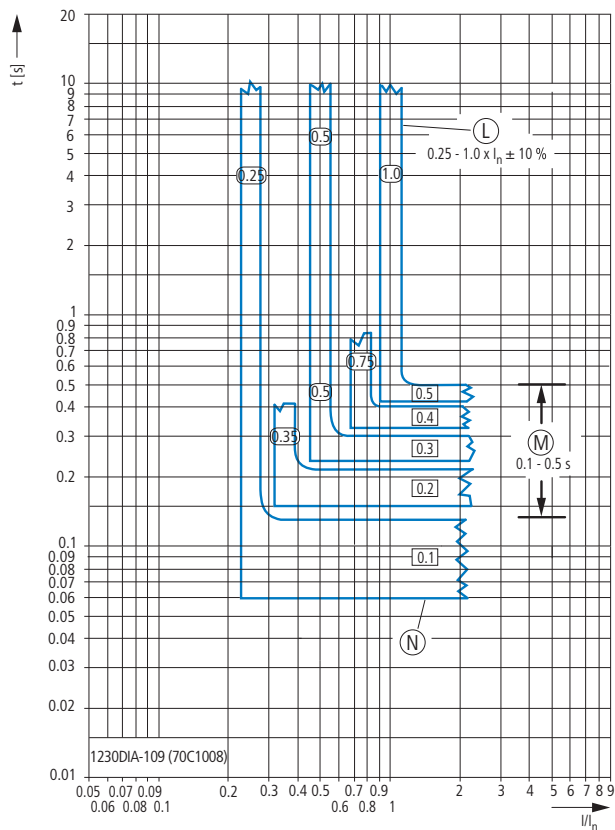

L Set values for ground-fault protection  
 M Set values for ground-fault protection delay at flat characteristic curve  
 N Flat characteristic curve for the delay time fault protection

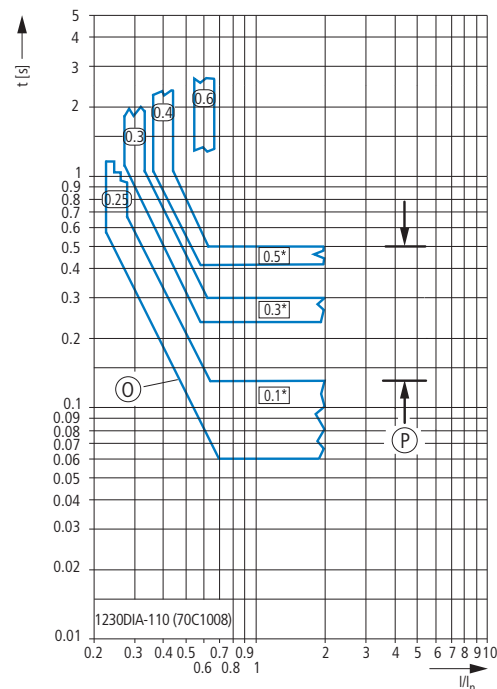

O I<sup>2</sup>t characteristic for ground-fault protection delay time  
 P Set values for ground-fault protection delay with I<sup>2</sup>t characteristic

info@tm2a.pt

WWW.TM2A.PT

info@tm2a.pt

WWW.TM2A.PT

**IZM26...U... Option Maintenance mode option +IZM-DTU-ARMS**

ARMS-maintenance mode  
See Notes 4, 6, 12, 18, 19, 20, 21.

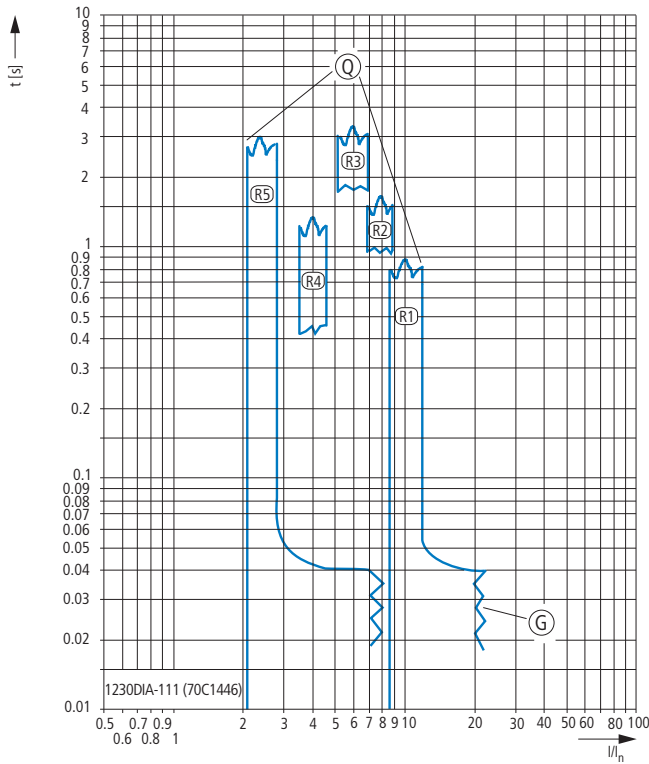

- G The end of the characteristic curve is determined by the type of application and the switching capacity of the selected switch.
- Q Set values for maintenance mode (ARMS):  
R5 = max. reduction,  
R1 = min. reduction



**IZM26...P... Tripping characteristics for universal protection with power measurement**

Overload protection (L) and short-time delayed short-circuit protection (S)

L-Protection:  $I^2t$  characteristic curve and S protection: flat characteristic curve      S protection:  $I^2t$  characteristic curve  
See Notes 1, 3, 7, 9, 22, 23, 24, 25, 26.      See Notes 1, 3, 7, 9, 22, 23, 24, 25, 26.

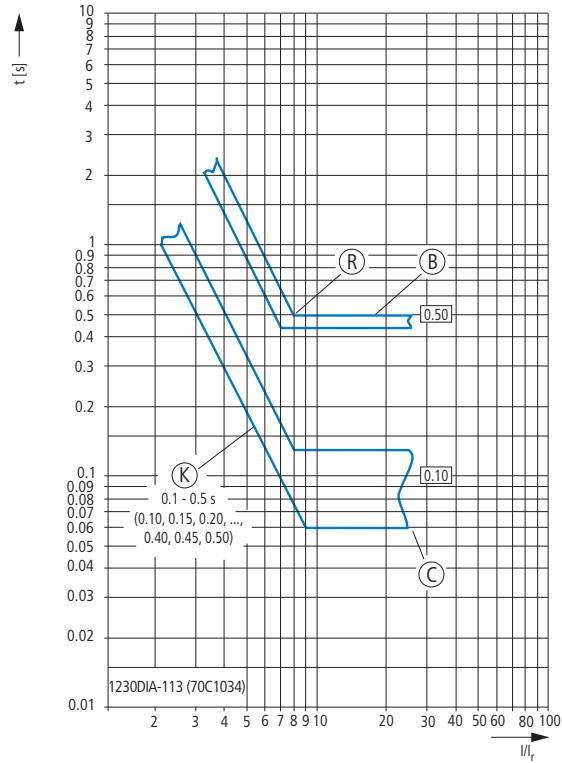
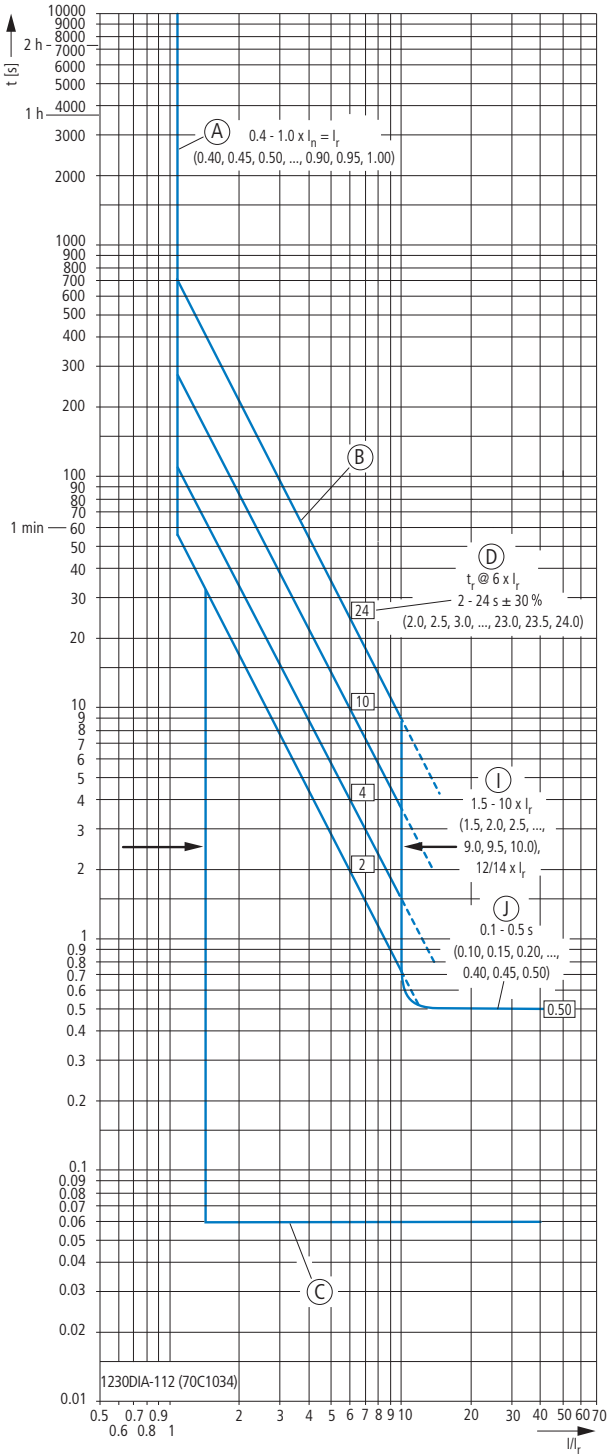

- B Maximum total opening delay
- C Minimum total opening delay
- K Set values for ground fault protection
- R Characteristic curve turning point

- A Set values for overload protection
- B Maximum total opening delay
- C Minimum total opening delay
- D Set values for long delay
- I Available set values for short-time delayed short-circuit protection  $I_{sd}$
- J Short-circuit release for very high currents

L protection: I<sup>2</sup>t characteristic curve and S protection: flat characteristic curve  
See Notes 1, 3, 7, 9, 22, 23, 24, 25, 27.

L protection: IEEE standard inverse tripping, and S protection: flat characteristic curve  
See Notes 3, 7, 8, 9, 23, 25, 28, 29.

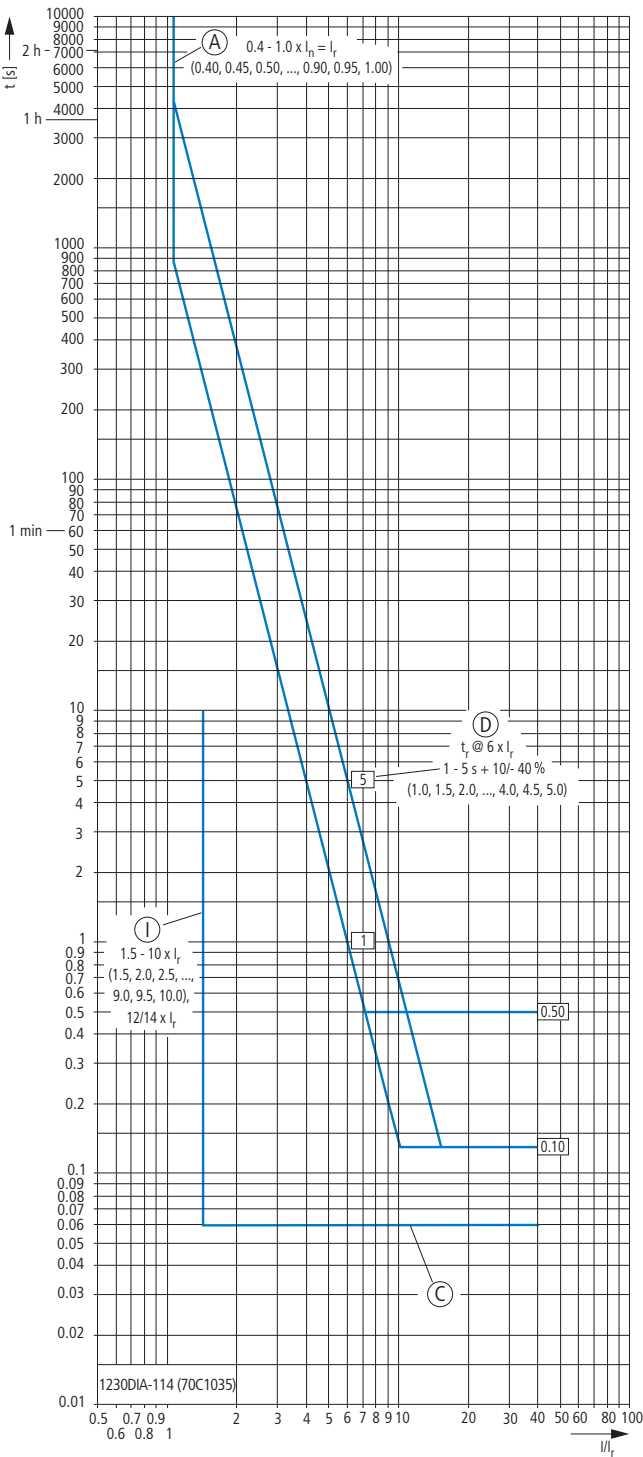

- A Set values for overload protection
- C Minimum total opening delay
- D Set values for long delay
- I Available set values for short-time delayed short-circuit protection I<sub>sd</sub>

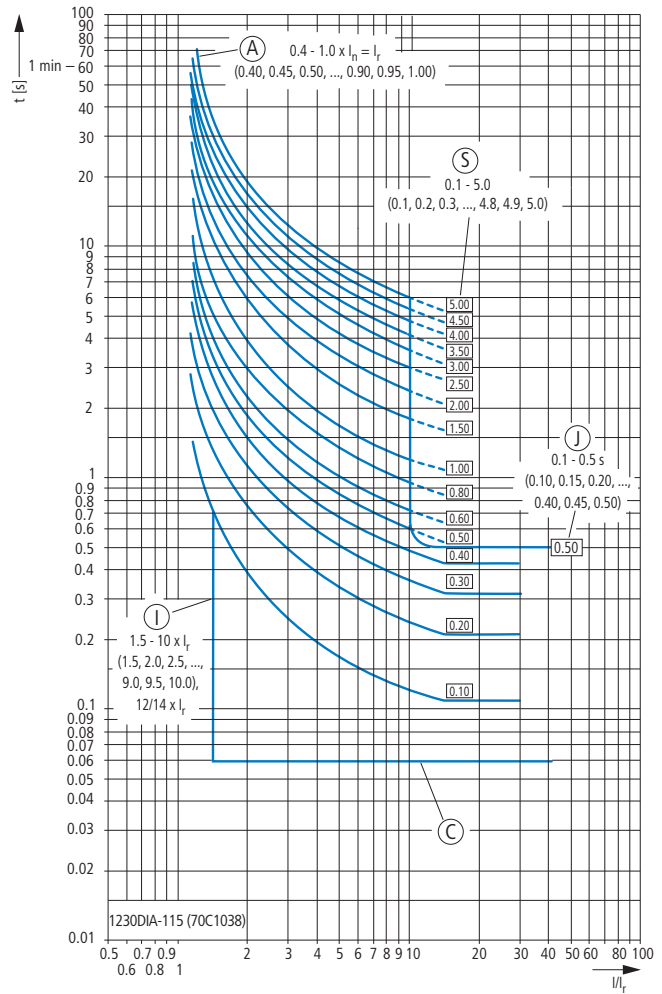

- A Set values for overload protection
- C Minimum total opening delay
- I Available set values for short-time delayed short-circuit protection I<sub>sd</sub>
- J Short-circuit release for very high currents
- S Long delay time at 14 × I<sub>r</sub>



L protection: IEEE high inverse tripping, and S protection: flat characteristic curve  
See Notes 3, 7, 8, 9, 23, 25, 28, 29.

L protection: IEEE extreme inverse tripping, and S protection: flat characteristic curve  
See Notes 3, 7, 8, 9, 23, 25, 28, 29.

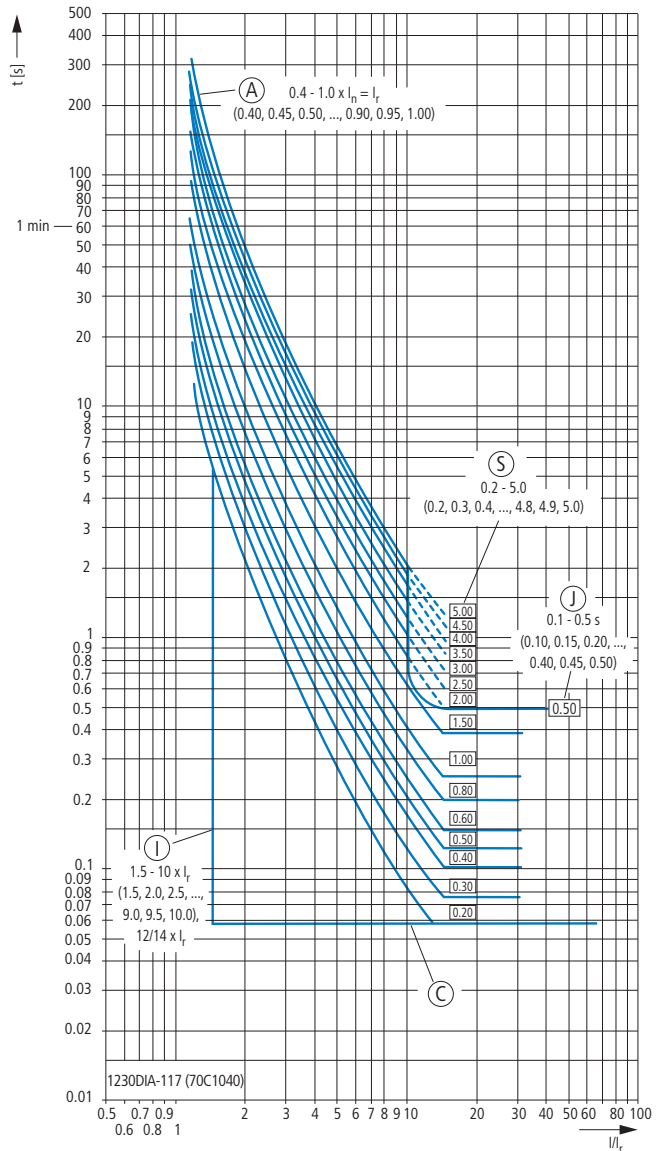
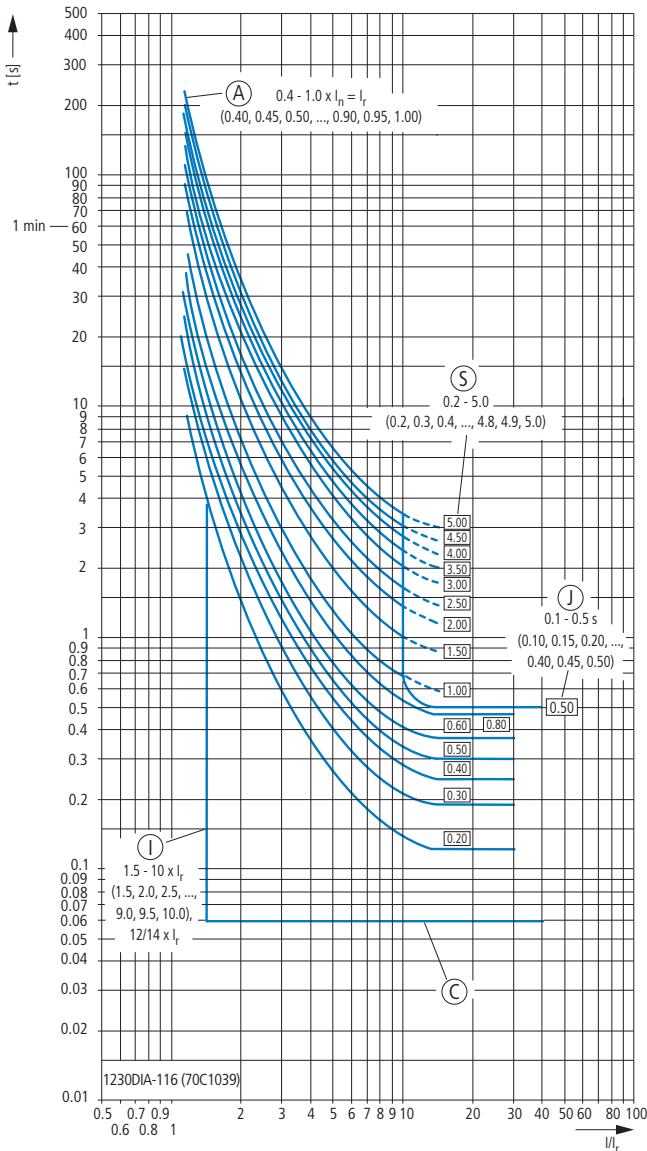

- A Set values for overload protection
- C Minimum total opening delay
- I Available set values for short-time delayed short-circuit protection  $I_{sd}$
- J Short-circuit release for very high currents
- S Long delay time at  $14 \times I_r$

- A Set values for overload protection
- C Minimum total opening delay
- I Available set values for short-time delayed short-circuit protection  $I_{sd}$
- J Short-circuit release for very high currents
- S Long delay time at  $14 \times I_r$

WWW.TM2A.PT info@tm2a.pt

WWW.TM2A.PT info@tm2a.pt





L protection: IEC-A standard inverse tripping, and S protection: flat characteristic curve  
See Notes 3, 7, 8, 9, 23, 25, 28, 29.

L protection: IEC-B high inverse tripping, and S protection: flat characteristic curve  
See Notes 3, 7, 8, 9, 23, 25, 28, 29.

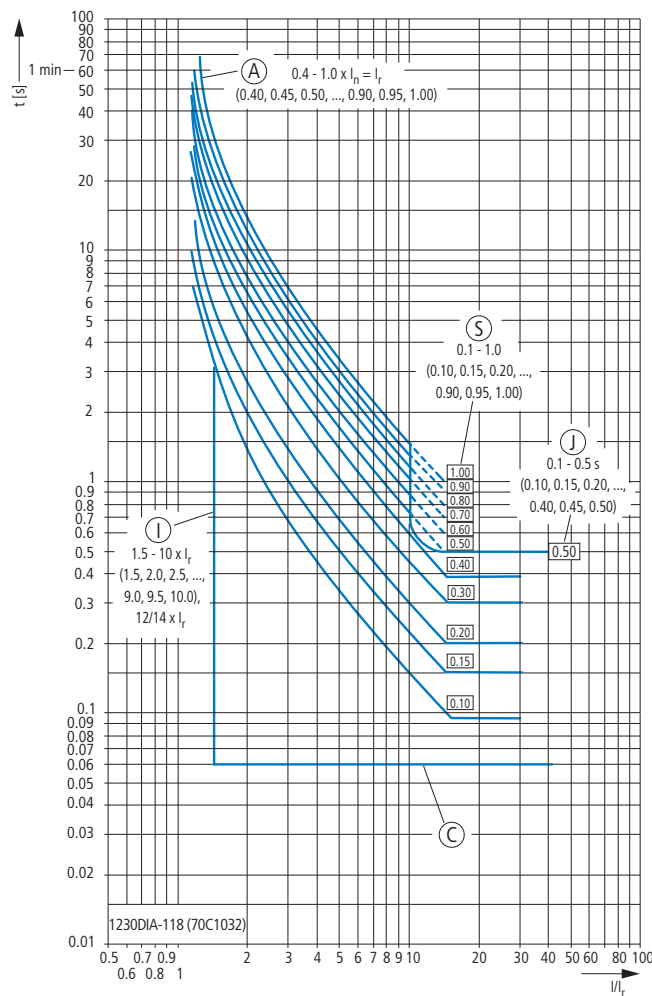
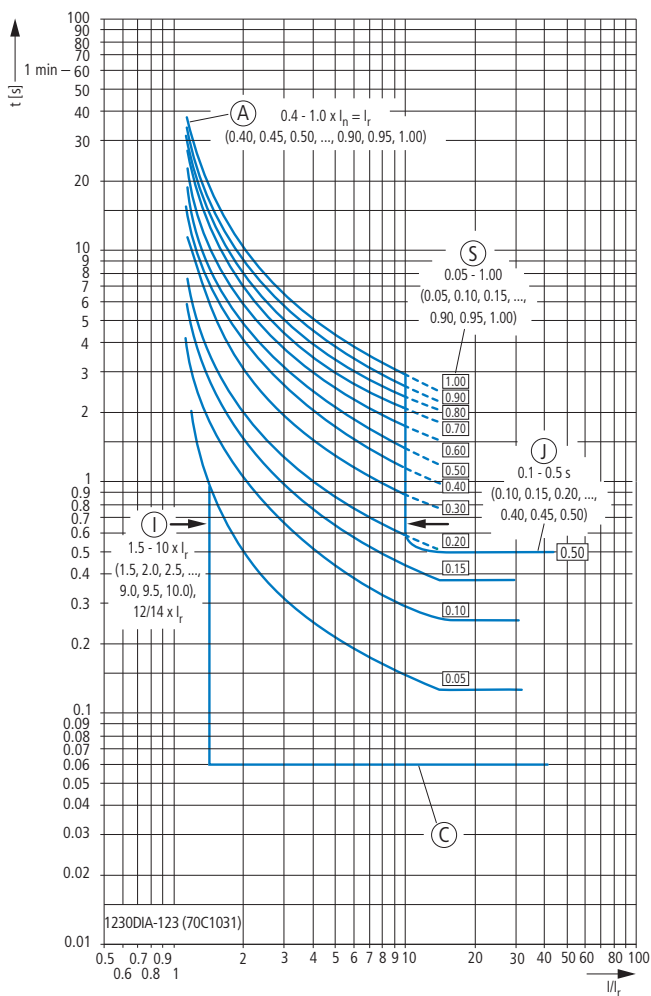

- A Set values for overload protection
- C Minimum total opening delay
- I Available set values for short-time delayed short-circuit protection  $I_{sd}$
- J Short-circuit release for very high currents
- S Long delay time at  $14 \times I_r$

- A Set values for overload protection
- C Minimum total opening delay
- I Available set values for short-time delayed short-circuit protection  $I_{sd}$
- J Short-circuit release for very high currents
- S Long delay time at  $14 \times I_r$



L protection: IEC-C extreme inverse tripping, and S protection: flat characteristic curve  
See Notes 3, 7, 8, 9, 23, 25, 28, 29.

IZM26...P... Tripping characteristics for trip units with power measurement  
Non-delayed short-circuit protection (I)

I-protection: Adjustable  
See Notes 1, 4, 5, 6, 7, 11, 12.

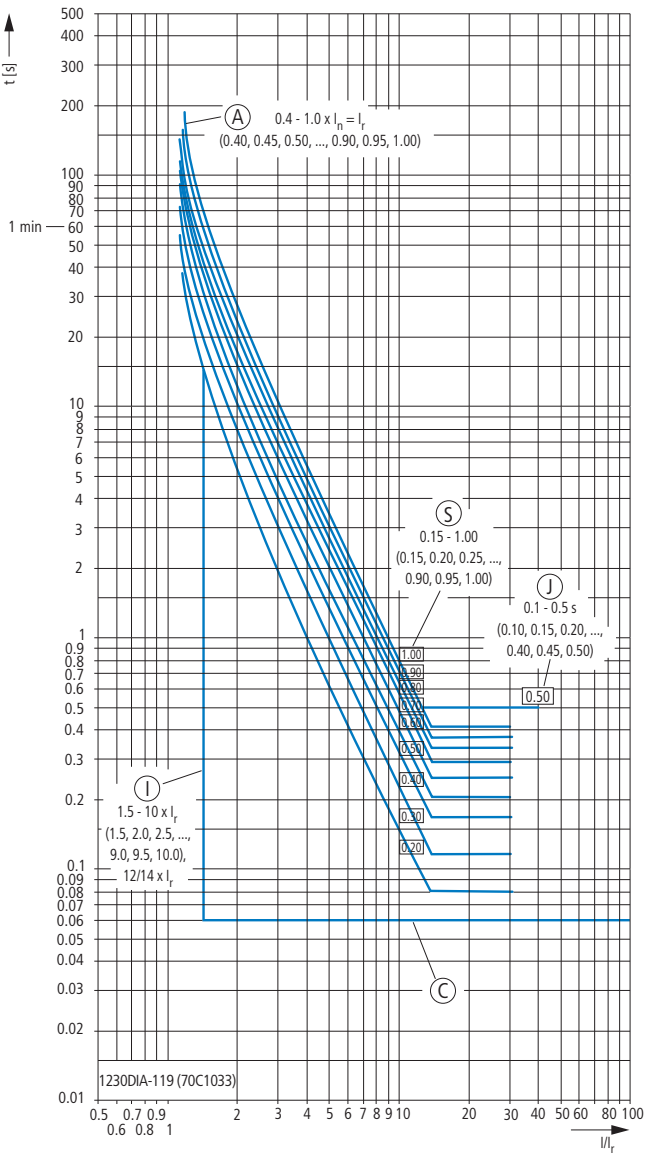

- A Set values for overload protection
- C Minimum total opening delay
- I Available set values for short-time delayed short-circuit protection  $I_{sd}$
- J Short-circuit release for very high currents
- S Long delay time at  $14 \times I_r$

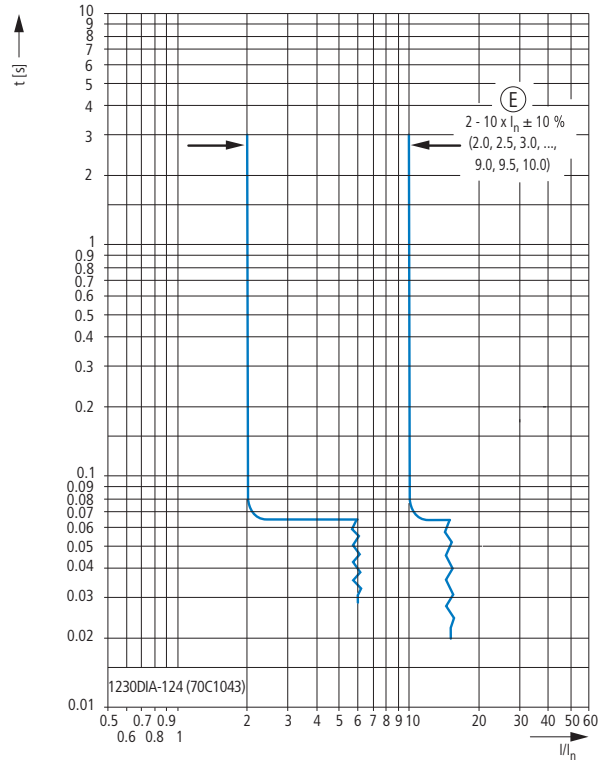

E Set values for short-time delayed short-circuit protection

I-protection: For high short-circuit currents

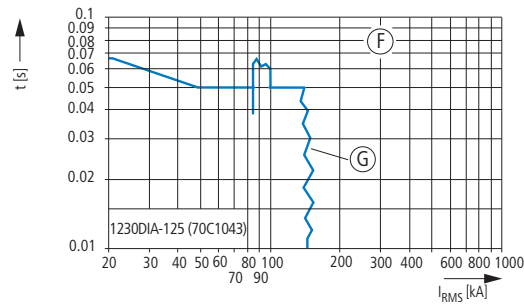

- F Set values for short-time delayed short-circuit protection with flat characteristic curve
- G The end of the characteristic curve is determined by the type of application and the switching capacity of the selected switch.

WWW.TM2A.PT info@tm2a.pt

WWW.TM2A.PT info@tm2a.pt



**IzM26...P... Option Ground fault protection +IzM-DTP-E...**

G: Ground fault protection, flat characteristic curve  
See Notes 4, 6, 13, 14, 15, 16, 25, 26, 30.

G: Ground fault protection, I<sup>2</sup>t-characteristic curve  
See Notes 4, 6, 13, 14, 15, 16, 25, 26, 30.

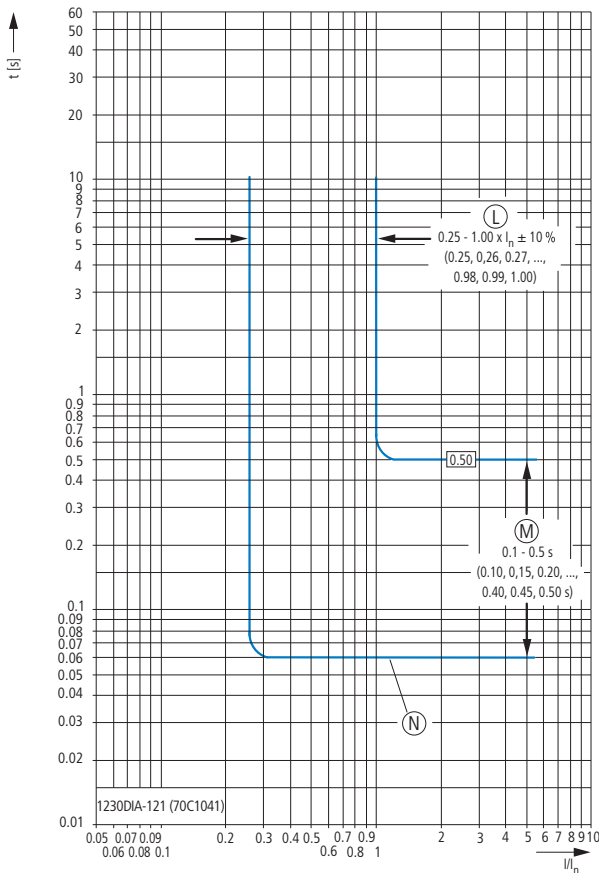

- L Set values for ground-fault protection
- M Set values for ground-fault protection delay at flat characteristic curve
- N Flat characteristic curve for the delay time fault protection

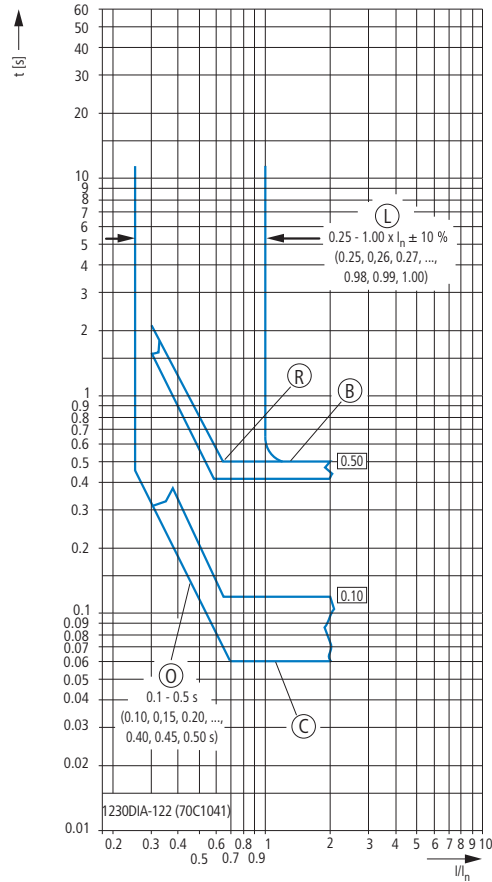

- B Maximum total opening delay
- C Minimum total opening delay
- L Set values for ground-fault protection
- O I<sup>2</sup>t characteristic for ground-fault protection delay time
- R Characteristic curve turning point

**IzM26...P... Option Maintenance mode option +IzM-DTP-ARMS**

ARMS-maintenance mode  
See Notes 4, 6, 12, 18, 19, 20, 21.

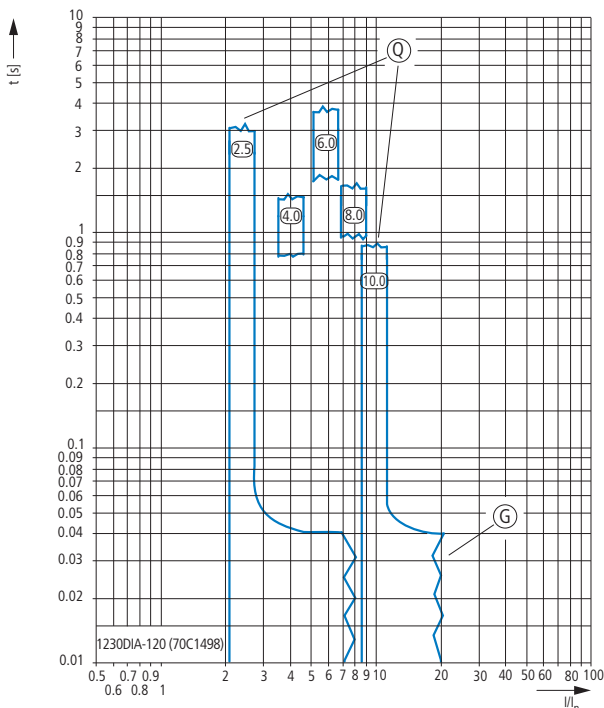

- G The end of the characteristic curve is determined by the type of application and the switching capacity of the selected switch.
- Q Set values for maintenance mode (ARMS):  
R5 = max. reduction, R1 = min. reduction



- 1 The trip unit has a thermal memory, which can shorten the tripping time in the overload range.  
  
This function plays a role whenever a current is higher than the overload release's tripping time and which is then isolated by a downstream circuit-breaker or the circuit-breaker itself. On a subsequent overload current the circuit-breaker will trip more quickly than normal.  
  
The reduced tripping time is inversely proportional to the time expired since the last overload. After about five minutes the thermal memory is reset.
- 2 The overload release is activated at a pick-up time of 110 %  $I_r$  with a tolerance of  $\pm 5$  % (indicated by the lit "Unit Status" LED).
- 3 The characteristic curves apply to applications in a temperature range from -20 °C to +55 °C. Temperatures over +85 °C cause automatic tripping. The circuit-breaker must be selected according to the temperature-dependent derating values from the table in the technical data.
- 4 The end of the characteristic curve is determined by the type of application and the switching capacity of the selected circuit-breaker.
- 5 The non-delayed short-circuit release is activated at a response value of conventionally 100 % with a tolerance of  $\pm 10$  %.
- 6 The listed overall switch-off times include the response times of the trip unit, the opening times of the switch and the time required to switch off the current.
- 7 Additional setting "max M1":  
**IZM20**  
M1 =  $14 \times I_n$  for nominal currents of 200 A to 1250 A  
M1 =  $12 \times I_n$  for nominal currents of 1600 A to 2000 A  
**IZM32**  
M1 =  $14 \times I_n$  for nominal currents of 200 A to 1250 A  
M1 =  $12 \times I_n$  for nominal currents of 1600 A to 2500 A  
M1 =  $10 \times I_n$  for nominal currents of 3200 A  
**IZM40**  
M1 =  $12 \times I_n$  for nominal currents of 4000 A  
**IZM63**  
M1 =  $14 \times I_n$  for nominal currents of 2000 A to 2500 A  
M1 =  $12 \times I_n$  for nominal currents of 3200 A to 5000 A  
M1 =  $10 \times I_n$  for nominal currents of 6300 A
- 8 The overload release trips at 110 %  $I_r$  with a tolerance of  $\pm 5$  % (indicated by the "Unit Status" LED).  
  
The short-time delayed short-circuit release  $I_{sd}$  is activated at a pick-up time of conventionally 100 % with a tolerance of  $\pm 5$  %.
- 9 When zone selectivity (ZSI) is activated in the short-time delayed short-circuit release and no blocking signal is applied, the minimum time value (0.10 s) applies irrespective of the short-time delay settings.
- 10 The upper lines of the  $I^2t$  characteristic curves are horizontal from a value of  $8 \times I_r$  (indicated by the points).
- 11 IZM circuit-breakers32 feature an additional, permanently set non-delayed short-circuit release, which is set to a peak value of 170 kA with a tolerance of  $\pm 10$  %.  
  
This protective function remains active when the non-delayed short-circuit release is switched off.
- 12 The listed overall switch-off times are conservative and take into account the trip unit's maximum response times, the circuit-breaker's maximum opening delays and the longest current interruption times with regard to factors that contribute to worst-case conditions, such as maximum rated operational voltage, single-phase interruptions and minimum power factor.  
  
Fast disconnecting times are possible but depend on the system conditions and the circuit-breaker model.
- 13 The ground-fault release is activated at a response value of conventionally 100 % with a tolerance of  $\pm 10$  %.
- 14 Unless otherwise specified, the current value tolerances are  $\pm 10$  % of the values shown in the diagram.
- 15 In combination with ARMS function, ground-fault protection is limited to 1200 A.
- 16 When zone selectivity (ZSI) is activated in ground-fault protection and no blocking signal is applied, the minimum time value (flat characteristic curve) applies irrespective of the settings.
- 17 The upper lines of the  $I^2t$  characteristic curves are horizontal from a value of  $0.625 \times I_n$  (indicated by the points).
- 18 The maintenance mode function must be activated with a switch or through the communications terminals for these characteristic curves to apply. A blue LED indicates that the maintenance mode settings are active.
- 19 The shown switch-off times apply for connection to an additional auxiliary power supply.
- 20 Tripping by the Maintenance Mode Trip is indicated by the non-delayed short-circuit protection LED.
- 21 The nominal reduction values (response values), with a tolerance of  $\pm 15$  % are:  
 $2.5 \times I_n$  (= R5),  $4 \times I_n$  (= R4),  $6 \times I_n$  (= R3),  $8 \times I_n$  (= R2),  $10 \times I_n$  (= R1)
- 22 This characteristic curve is shown as a multiple of the overload release setting  $I_r$ . The overload release trips at 110 %  $I_r$  with a tolerance of  $\pm 5$  % (indicated by the "Unit Status" LED).
- 23 The delayed short-circuit release  $I_{sd}$  also has an "M1" setting, which may increase the response threshold when  $I_{sd}$  is active (at the curves' point of overlap).
- 24 The delayed short-circuit release  $I_{sd}$  trips at 100 %, with a tolerance of  $\pm 5$  %.
- 25 Delay tolerances in the area of the flat characteristic curve:  
The tolerance is +0/-80 ms of the set values, with the following exceptions:  
At 100 ms the tolerance is 6 to 13 ms  
At 150 ms the tolerance is 10 to 17 ms  
At 200 ms the tolerance is 15 to 22 ms
- 26  $I^2t$ -function  
The upper lines of the  $I^2t$  characteristic curves are horizontal from a value of  $8 \times I_r$  (for ground-fault protection  $0.625 \times I_n$ ), the lower limit value of the band following the line.  
  
The characteristic curve has a tolerance of +0/-30 % for all settings except the following ones:  
For 0.10 s +30 %/-25 %  
For 0.15 s +20 %/-25 %  
For 0.20 s +10 %/-25 %  
  
For all characteristic curves the lower, minimum time value, which merges with the  $I^2t$  line, determines the break point and the shape of the upper characteristic curve.
- 27 In the time range  $\leq 0.5$  s the  $I^2t$  characteristic curve becomes horizontal. Tripping does not take place faster than the set short-time delay  $t_{sd}$ . (In the drawing a displacement of the characteristic curve is avoided.)
- 28 This characteristic curve is shown as a multiple of the overload release setting  $I_r$ .  
  
This so-called "E-/IEC-... inverse" characteristic curve results from the time setting "TimeDial" in combination with the delayed short-circuit release  $I_{sd}$  and the delay  $t_{sd}$  (shown as thick lines). The non-delayed short-circuit release  $I_r$ , shown as a separate characteristic curve, can be disabled (Off position).



- 29 For each current  $> 1.2 \times I_r$ , the tolerance is  $[\pm 15 \ %]$  or  $[-15 \ %, +90 \ ms]$ , whichever is greater.

This characteristic curve flattens out for smaller time settings ("TimeDial": 0.1 to 0.4) at  $14 \times I_r$  and, if the curves overlap, merges with the characteristic curve for short-term delay  $I_{sd}$  for larger time settings ("TimeDial": 0.5 to 1.0).

The delay of the short-circuit release and the "TimeDial" time setting are applied independently of each other. The IEC-B (very inverse) characteristic curve always remains active, even when the lines cross over.

- 30 With Digitrip 1150 trip unit without ARMS function the ground-fault protection settings already begin at  $0.1 \times I_n$ .

- A Set values for overload protection  $I_r$
- B Maximum total opening delay
- C Minimum total opening delay
- D Set value for long delay  $t_r$
- E Set value non-delayed short-circuit protection  $I_i$
- F Set values for short-time delayed short-circuit protection with flat characteristic curve
- G The end of the characteristic curve is determined by the type of application and the switching capacity of the selected switch.
- H Setting values for short time delay with  $i^2t$  characteristic.
- I Available set values for short-time delayed short-circuit protection  $I_{sd}$
- J Short-circuit release for very high currents
- KP Set values for short-time delay at  $I^2t$  characteristic
- L Set values for ground fault protection
- M Set values for ground-fault protection delay at flat characteristic curve
- N Flat characteristic curve for the deceleration time Ground fault protection
- O  $I^2t$  characteristic for ground-fault protection delay time
- P Set values for ground-fault protection delay with  $I^2t$  characteristic
- q Set values for maintenance mode (ARMS):  
R5 = max. reduction,  
R1 = min. reduction
- R Characteristic curve turning point
- S Long delay time with  $14 \times I_r$



## Rating-Plug-Combinations for IZM20...

## Rating plugs (plus types, 3 pole)

$I_n$ [A]	$I_u$ [A]	800	1000	1250	1600	2000
200				+IZM-RP203-200		
250				+IZM-RP203-250		
300				+IZM-RP203-300		
400				+IZM-RP203-400		
630				+IZM-RP203-630		
800	Standard	+IZM-RP203-800				
1000		Standard	+IZM-RP203-1000			
1250			Standard	+IZM-RP203-1250		
1600				Standard	+IZM-RP203-1600	
2000					Standard	

## Rating plugs (plus types, 4 pole)

$I_n$ [A]	$I_u$ [A]	800	1000	1250	1600	2000
200				+IZM-RP204-200		
250				+IZM-RP204-250		
300				+IZM-RP204-300		
400				+IZM-RP204-400		
630				+IZM-RP204-630		
800	Standard	+IZM-RP204-800				
1000		Standard	+IZM-RP204-1000			
1250			Standard	+IZM-RP204-1250		
1600				Standard	+IZM-RP204-1600	
2000					Standard	

## Rating-Plug-Combinations for IZM32...

## Rating plugs (plus types, 3 pole)

$I_n$ [A]	$I_u$ [A]	800	1000	1250	1600	2000	2500	3200
200					+IZM-RP323-200			
250					+IZM-RP323-250			
300					+IZM-RP323-300			
400					+IZM-RP323-400			
630					+IZM-RP323-630			
800	Standard	+IZM-RP323-800						
1000		Standard	+IZM-RP323-1000					
1250			Standard	+IZM-RP323-1250				
1600				Standard	+IZM-RP323-1600			
2000					Standard	+IZM-RP323-2000		
2500						Standard	+IZM-RP323-2500	
3200							Standard	

## Rating plugs (plus types, 4 pole)

$I_n$ [A]	$I_u$ [A]	800	1000	1250	1600	2000	2500	3200
200					+IZM-RP324-200			
250					+IZM-RP324-250			
300					+IZM-RP324-300			
400					+IZM-RP324-400			
630					+IZM-RP324-630			
800	Standard	+IZM-RP324-800						
1000		Standard	+IZM-RP324-1000					
1250			Standard	+IZM-RP324-1250				
1600				Standard	+IZM-RP324-1600			
2000					Standard	+IZM-RP324-2000		
2500						Standard	+IZM-RP324-2500	
3200							Standard	



Rating-Plug-Combinations for IZM40...

Rating plugs (plus types, 3- and 4 pole)

I <sub>n</sub> [A]	3 pole		4 pole
	I <sub>u</sub> [A]	4000	4000
2000		+IZM-RP403-2000	+IZM-RP404-2000
2500		+IZM-RP403-2500	+IZM-RP404-2500
3200		+IZM-RP403-3200	+IZM-RP404-3200
4000		Standard	Standard

Rating-Plug-Combinations for IZM63...

Rating plugs (plus types, 3 pole)

I <sub>n</sub> [A]	I <sub>u</sub> [A]		
	4000	5000	6300
2000		+IZM-RP633-2000	
2500		+IZM-RP633-2500	
3200		+IZM-RP633-3200	
4000	Standard	+IZM-RP633-4000	
5000		Standard	+IZM-RP633-5000
6300			Standard

Rating plugs (plus types, 4 pole)

I <sub>n</sub> [A]	I <sub>u</sub> [A]		
	4000	5000	6300
2000		+IZM-RP634-2000	
2500		+IZM-RP634-2500	
3200		+IZM-RP634-3200	
4000	Standard	+IZM-RP634-4000	
5000		Standard	+IZM-RP634-5000
6300			Standard

WWW.TM2A.PT info@tm2a.pt

WWW.TM2A.PT info@tm2a.pt



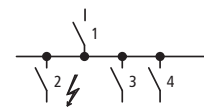

I<sub>n</sub>: Rated operational current
I<sub>u</sub>: Rated uninterrupted current
I<sub>cu</sub>: Rated short-circuit breaking capacity
I<sub>i</sub>: Set value non-delayed short-circuit releases

Selectivity 415 V AC
between circuit-breakers enables the separate isolation of faulty system sections.
Selectivity exists between incoming circuit-breaker 1 and outgoing circuit-breaker 2 if, only outgoing circuit-breaker 2 trips at position 2 during a short-circuit.
System sections 3 and 4 remain operational.

Selection:
Provided that the short-circuit current does not exceed those values specified (I<sub>cc rms</sub>).
These details represent the limits of selectivity.
Both circuit-breakers will switch off with higher short-circuit currents.
On I ZM circuit-breakers with V, U, P releases, the delay time t<sub>sd</sub> must be at least 100 ms longer than the delay time of the next downstream levels (2, 3, 4).

Table with columns for Incoming circuit-breaker (1) and Outgoing circuit-breaker (2), and rows for I<sub>n</sub> [A], I<sub>cu</sub> [kA], and I<sub>i</sub> [A].

Large table showing prospective short-circuit current (I<sub>cc rms</sub> in kA) for various circuit-breaker models like NZMB(C)(N)(H)1-A(M)... and NZMC(N)(H)3-A(M)(V)...

Notes B = Basic switching capacity, N = Normal switching capacity, H = High switching capacity, T = Total selectivity

Table with columns for I ZM...20-U and I ZM20...-P, and rows for I<sub>n</sub> [A], I<sub>cu</sub> [kA], and I<sub>i</sub> [A].

Large table showing prospective short-circuit current (I<sub>cc rms</sub> in kA) for various circuit-breaker models like NZMB(C)(N)(H)1-A(M)... and NZMC(N)(H)3-A(M)(V)...

Notes B = Basic switching capacity, N = Normal switching capacity, H = High switching capacity, T = Total selectivity

WWW.TM2A.PT info@tm2a.pt

WWW.TM2A.PT info@tm2a.pt





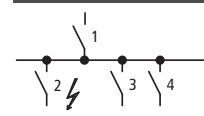

I<sub>n</sub>: Rated operational current  
I<sub>u</sub>: Rated uninterrupted current  
I<sub>cu</sub>: Rated short-circuit breaking capacity  
I<sub>s</sub>: Set value non-delayed short-circuit releases

**Selectivity 415 V AC**  
between circuit-breakers enables the separate isolation of faulty system sections. Selectivity exists between incoming circuit-breaker 1 and outgoing circuit-breaker 2 if, only outgoing breaker 2 trips at position 2 during a short-circuit. System sections 3 and 4 continue to operate.

**Selection:**  
Provided that the short-circuit current does not exceed those values specified (I<sub>cc rms</sub>). These details represent the limits of selectivity. Both circuit-breakers will switch off with higher short-circuit currents. On I ZM circuit-breakers with V, U, P releases, the delay time t<sub>sd</sub> must be at least 100 ms longer than the delay time of the next downstream levels (2, 3, 4).

Table with columns for Incoming circuit-breaker (1) and Outgoing circuit-breaker (2). Rows include I<sub>n</sub> [A], I<sub>cu</sub> [kA], and I<sub>s</sub> [A].

Large table showing Prospective short-circuit current (I<sub>cc rms</sub> in kA) for various breaker models and ratings. Columns include breaker model and current ratings.

Notes B = Basic switching capacity, N = Normal switching capacity, H = High switching capacity, T = Total selectivity

Table for I ZM32...-P showing I<sub>n</sub> [A], I<sub>cu</sub> [kA], and I<sub>s</sub> [A] for various breaker models and ratings.

Large table showing Prospective short-circuit current (I<sub>cc rms</sub> in kA) for various breaker models and ratings. Columns include breaker model and current ratings.

Notes B = Basic switching capacity, N = Normal switching capacity, H = High switching capacity, T = Total selectivity

WWW.TM2A.PT info@tm2a.pt

WWW.TM2A.PT info@tm2a.pt

Selectivity: incoming circuit-breaker, outgoing circuit-breaker

I<sub>ZM</sub>40...

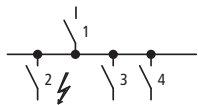

$I_n$ : Rated operational current  
 $I_u$ : Rated uninterrupted current  
 $I_{cu}$ : Rated short-circuit breaking capacity  
 $I_i$ : Set value non-delayed short-circuit release

**Selectivity 415 V AC**  
 between circuit-breakers enables the separate isolation of faulty system sections.  
 Selectivity exists between incoming circuit-breaker 1 and outgoing circuit-breaker 2 if, only outgoing breaker 2 trips at position 2 during a short-circuit. System sections 3 and 4 remain operational.

**Selection:**  
 Provided that the short-circuit current does not exceed those values specified ( $I_{cc\ rms}$ ). These details represent the limits of selectivity. Both circuit-breakers will switch off with higher short-circuit currents. On I<sub>ZM</sub> circuit-breakers with V, U, P releases, the delay time  $t_{sg}$  must be at least 100 ms longer than the delay time of the next downstream levels (2, 3, 4).

	Incoming circuit-breaker	I <sub>ZM</sub> ...40-V		I <sub>ZM</sub> ...40-U		I <sub>ZM</sub> 40...-P	
	$I_n$ [A]	4000	4000	4000	4000	4000	4000
	$I_{cu}$ [kA]	85	100	85	100	85	100
	$I_i$ [A]	48000	48000	48000	48000	48000	48000
<b>Outgoing circuit-breaker (2)</b>	$I_u$ [A]	N	H	N	H	N	H
	$I_{cu2(415V)}$ [kA]						

			Prospective short-circuit current ( $I_{cc\ rms}$ in kA)					
NZMB(C)(N)(H)1-A(M)...	20	25 - 100	T	T	T	T	T	T
	25	25 - 100	T	T	T	T	T	T
	32	25 - 100	T	T	T	T	T	T
	40	25 - 100	T	T	T	T	T	T
	50	25 - 100	T	T	T	T	T	T
	63	25 - 100	T	T	T	T	T	T
	80	25 - 100	T	T	T	T	T	T
	100	25 - 100	T	T	T	T	T	T
	125	25 - 100	T	T	T	T	T	T
	160	25 - 100	T	T	T	T	T	T
NZMB(C)(N)(H)2-A(M)(V)...	20	25 - 150	T	T	T	T	T	T
	25	25 - 150	T	T	T	T	T	T
	32	25 - 150	T	T	T	T	T	T
	40	25 - 150	T	T	T	T	T	T
	50	25 - 150	T	T	T	T	T	T
	63	25 - 150	T	T	T	T	T	T
	80	25 - 150	T	T	T	T	T	T
	90	25 - 150	T	T	T	T	T	T
	100	25 - 150	T	T	T	T	T	T
	125	25 - 150	T	T	T	T	T	T
	140	25 - 150	T	T	T	T	T	T
	160	25 - 150	T	T	T	T	T	T
	200	25 - 150	T	T	T	T	T	T
	220	25 - 150	T	T	T	T	T	T
	250	25 - 150	T	T	T	T	T	T
300	25 - 150	T	T	T	T	T	T	
NZMC(N)(H)3-A(M)(V)...	220	36 - 150	T	T	T	T	T	T
	250	36 - 150	T	T	T	T	T	T
	320	36 - 150	T	T	T	T	T	T
	350	36 - 150	T	T	T	T	T	T
	400	36 - 150	T	T	T	T	T	T
	450	36 - 150	T	T	T	T	T	T
	500	36 - 150	T	T	T	T	T	T
	630	36 - 150	T	T	T	T	T	T
NZMN(H)4-A(M)(V)...	550	50 - 100	T	T	T	T	T	T
	630	50 - 100	T	T	T	T	T	T
	800	50 - 100	T	T	T	T	T	T
	875	50 - 100	T	T	T	T	T	T
	1000	50 - 100	T	T	T	T	T	T
	1250	50 - 100	T	T	T	T	T	T
	1400	50 - 100	T	T	T	T	T	T
	1600	50 - 100	T	T	T	T	T	T

**Notes** B = Basic switching capacity, N = Normal switching capacity, H = High switching capacity, T = Total selectivity

WWW.TM2A.PT info@tm2a.pt

WWW.TM2A.PT info@tm2a.pt



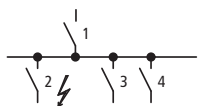

$I_n$ : Rated operational current  
 $I_u$ : Rated uninterrupted current  
 $I_{cu}$ : Rated short-circuit breaking capacity  
 $I_i$ : Set value non-delayed short-circuit releases

**Selectivity 415 V AC**

between circuit-breakers enables the separate isolation of faulty system sections. Selectivity exists between incoming circuit-breaker 1 and outgoing circuit-breaker 2 if, only outgoing breaker 2 trips at position 2 during a short-circuit. System sections 3 and 4 continue to operate.

**Selection:**

Provided that the short-circuit current does not exceed those values specified ( $I_{cc\ rms}$ ). These details represent the limits of selectivity. Both circuit-breakers will switch off with higher short-circuit currents. On IZM circuit-breakers with V, U, P releases, the delay time  $t_{sd}$  must be at least 100 ms longer than the delay time of the next downstream levels (2, 3, 4).

Incoming circuit-breaker (1)	IZM...63-V				IZM...63-U				IZM63...-P										
	$I_n$ [A]	4000	4000	5000	5000	6300	6300	4000	4000	5000	5000	6300	6300	4000	4000	5000	5000	6300	6300
$I_{cu}$ [kA]	85	100	85	100	85	100	85	100	85	100	85	100	85	100	85	100	85	100	
$I_i$ [A]	48000	48000	60000	60000	63000	63000	48000	48000	60000	60000	63000	63000	48000	48000	60000	60000	63000	63000	
Outgoing circuit-breaker (2)	$I_u$ [A]	N		H		N		H		N		H		N		H		N	
	$I_{cu2(415V)}$ [kA]	N		H		N		H		N		H		N		H		N	

		Prospective short-circuit current ( $I_{cc\ rms}$ in kA)																	
NZMB(C)(N)(H) 1-A(M)...	20	25 - 100	T	T	T	T	T	T	T	T	T	T	T	T	T	T	T	T	T
	25	25 - 100	T	T	T	T	T	T	T	T	T	T	T	T	T	T	T	T	T
	32	25 - 100	T	T	T	T	T	T	T	T	T	T	T	T	T	T	T	T	T
	40	25 - 100	T	T	T	T	T	T	T	T	T	T	T	T	T	T	T	T	T
	50	25 - 100	T	T	T	T	T	T	T	T	T	T	T	T	T	T	T	T	T
	63	25 - 100	T	T	T	T	T	T	T	T	T	T	T	T	T	T	T	T	T
	80	25 - 100	T	T	T	T	T	T	T	T	T	T	T	T	T	T	T	T	T
	100	25 - 100	T	T	T	T	T	T	T	T	T	T	T	T	T	T	T	T	T
	125	25 - 100	T	T	T	T	T	T	T	T	T	T	T	T	T	T	T	T	T
160	25 - 100	T	T	T	T	T	T	T	T	T	T	T	T	T	T	T	T	T	
NZMB(C)(N)(H) 2-A(M)(V)...	20	25 - 150	T	T	T	T	T	T	T	T	T	T	T	T	T	T	T	T	T
	25	25 - 150	T	T	T	T	T	T	T	T	T	T	T	T	T	T	T	T	T
	32	25 - 150	T	T	T	T	T	T	T	T	T	T	T	T	T	T	T	T	T
	40	25 - 150	T	T	T	T	T	T	T	T	T	T	T	T	T	T	T	T	T
	50	25 - 150	T	T	T	T	T	T	T	T	T	T	T	T	T	T	T	T	T
	63	25 - 150	T	T	T	T	T	T	T	T	T	T	T	T	T	T	T	T	T
	80	25 - 150	T	T	T	T	T	T	T	T	T	T	T	T	T	T	T	T	T
	90	25 - 150	T	T	T	T	T	T	T	T	T	T	T	T	T	T	T	T	T
	100	25 - 150	T	T	T	T	T	T	T	T	T	T	T	T	T	T	T	T	T
	125	25 - 150	T	T	T	T	T	T	T	T	T	T	T	T	T	T	T	T	T
	140	25 - 150	T	T	T	T	T	T	T	T	T	T	T	T	T	T	T	T	T
	160	25 - 150	T	T	T	T	T	T	T	T	T	T	T	T	T	T	T	T	T
	200	25 - 150	T	T	T	T	T	T	T	T	T	T	T	T	T	T	T	T	T
	220	25 - 150	T	T	T	T	T	T	T	T	T	T	T	T	T	T	T	T	T
250	25 - 150	T	T	T	T	T	T	T	T	T	T	T	T	T	T	T	T	T	
300	25 - 150	T	T	T	T	T	T	T	T	T	T	T	T	T	T	T	T	T	
NZMC(N)(H) 3-A(M)(V)...	220	36 - 150	T	T	T	T	T	T	T	T	T	T	T	T	T	T	T	T	T
	250	36 - 150	T	T	T	T	T	T	T	T	T	T	T	T	T	T	T	T	T
	320	36 - 150	T	T	T	T	T	T	T	T	T	T	T	T	T	T	T	T	T
	350	36 - 150	T	T	T	T	T	T	T	T	T	T	T	T	T	T	T	T	T
	400	36 - 150	T	T	T	T	T	T	T	T	T	T	T	T	T	T	T	T	T
	450	36 - 150	T	T	T	T	T	T	T	T	T	T	T	T	T	T	T	T	T
	500	36 - 150	T	T	T	T	T	T	T	T	T	T	T	T	T	T	T	T	T
	630	36 - 150	T	T	T	T	T	T	T	T	T	T	T	T	T	T	T	T	T
NZMN(H) 4-A(M)(V)...	550	50 - 100	T	T	T	T	T	T	T	T	T	T	T	T	T	T	T	T	T
	630	50 - 100	T	T	T	T	T	T	T	T	T	T	T	T	T	T	T	T	T
	800	50 - 100	T	T	T	T	T	T	T	T	T	T	T	T	T	T	T	T	T
	875	50 - 100	T	T	T	T	T	T	T	T	T	T	T	T	T	T	T	T	T
	1000	50 - 100	T	T	T	T	T	T	T	T	T	T	T	T	T	T	T	T	T
	1250	50 - 100	T	T	T	T	T	T	T	T	T	T	T	T	T	T	T	T	T
	1400	50 - 100	T	T	T	T	T	T	T	T	T	T	T	T	T	T	T	T	T
	1600	50 - 100	T	T	T	T	T	T	T	T	T	T	T	T	T	T	T	T	T

**Notes** B = Basic switching capacity, N = Normal switching capacity, H = High switching capacity, T = Total selectivity

WWW.TM2A.PT info@tm2a.pt

WWW.TM2A.PT info@tm2a.pt



				IZM20B...08...	IZM20B...10...	IZM20B...12...
<b>General</b>						
Standards				IEC/EN 60947		
Ambient temperature	Storage	°C	-40 - +70 (Devices with LCD display -20 - +70)			
	Operation (open)	°C	-25 - +70 (Devices with LCD display -20 - +70)			
Built-in position						
Utility category				B	B	B
Protection type				IP20, IP54 with protective cover		
Direction of incoming supply				Any		
<b>Main contacts</b>						
Rated operational current = Rated uninterrupted current	$I_n = I_u$	A	800	1000	1250	
Rated uninterrupted current at 50 °C <sup>1)</sup>	$I_u$	A	800	1000	1250	
Rated uninterrupted current at 60 °C <sup>1)</sup>	$I_u$	A	800	1000	1100	
Rated uninterrupted current at 70 °C <sup>1)</sup>	$I_u$	A	800	1000	1000	
Rated impulse withstand voltage	$U_{imp}$	V AC	8000	8000	8000	
Rated operational voltage	$U_e$	V AC	690	690	690	
Use in IT electrical power networks up to U = 440 V	$I_{IT}$	kA	21	21	21	
Use in IT electrical power networks up to U = 690 V	$I_{IT}$	kA	—	—	—	
Overvoltage category/pollution degree				III/3		
Rated insulation voltage				1000		
<b>Switching capacity</b>						
Rated short-circuit making capacity	Up to 440 V 50/60 Hz	$I_{cm}$	kA	105	105	105
	Up to 690 V 50/60 Hz	$I_{cm}$	kA	105	105	105
Rated short-time withstand current 50/60 Hz	t = 1 s	$I_{cw}$	kA	50	50	50
	t = 3 s	$I_{cw}$	kA	—	—	—
Rated short-circuit breaking capacity $I_{cn}$						
IEC/EN 60947 Operating sequence $I_{cu}$ 0-t-CO						
Up to 240 V 50/60 Hz		$I_{cu}$	kA	50	50	50
Up to 440 V 50/60 Hz		$I_{cu}$	kA	50	50	50
Up to 690 V 50/60 Hz		$I_{cu}$	kA	50	50	50
Up to 1100 V 50/60 Hz		$I_{cu}$	kA	—	—	—
IEC/EN 60947 Operating sequence $I_{cs}$ 0-t-CO-t-CO						
Up to 240 V 50/60 Hz		$I_{cs}$	kA	50	50	50
Up to 440 V 50/60 Hz		$I_{cs}$	kA	50	50	50
Up to 690 V 50/60 Hz		$I_{cs}$	kA	50	50	50
Up to 1100 V 50/60 Hz		$I_{cs}$	kA	—	—	—
<b>Switching times</b>						
Total opening delay		ms	30	30	30	
Closing delay		ms	35	35	35	
Closing delay electrical (via closing release)		ms	40	40	40	
Opening delay electrical ( via shunt release / undervoltage release)		ms	35/70	35/70	35/70	
Opening delay via trip electronics (non-delayed short-circuit release)		ms	35	35	35	
<b>Durability</b>						
Mechanical, without maintenance		Operations	12500	12500	12500	
Mechanical, with maintenance		Operations	20000	20000	20000	
Electrical, without maintenance		Operations	10000	10000	10000	
Electrical, with maintenance		Operations	10000	10000	10000	
Maximum operating frequency		Operations/h	60	60	60	
Heat dissipation at rated operational current $I_n$ 3-phase symmetric loading	Fixed	W	60	95	150	
	Withdrawable	W	110	170	260	
<b>Weight</b>						
Fixed	3 pole	kg	43	43	43	
	4 pole	kg	54	54	54	
Withdrawable	3 pole	kg	48	48	48	
	4 pole	kg	62	62	62	
Empty cassette	3 pole	kg	34	34	34	
	4 pole	kg	38	38	38	

**Notes** <sup>1)</sup> Permissible continuous current for circuit-breakers used at different temperatures within switchgear. The expected internal temperatures can be estimated according to the applicable IEC regulations.

IZM20B...16...	IZM20B...20...	IZM20N...08...	IZM20N...10...	IZM20N...12...	IZM20N...16...	IZM20N...20...
IEC/EN 60947						
-40 - +70 (Devices with LCD display -20 - +70)						
-25 - +70 (Devices with LCD display -20 - +70)						
						
B	B	B	B	B	B	B
IP20, IP54 with protective cover						
Any						
1600	2000	800	1000	1250	1600	2000
1600	2000	800	1000	1250	1600	2000
1500	1800	800	1000	1100	1500	1800
1350	1650	800	1000	1000	1350	1650
8000	8000	8000	8000	8000	8000	8000
690	690	690	690	690	690	690
23	32	21	21	21	23	32
—	—	—	—	—	—	—
III/3	III/3	III/3	III/3	III/3	III/3	III/3
1000	1000	1000	1000	1000	1000	1000
105	105	137	137	137	137	137
105	105	137	137	137	137	137
50	50	65	65	65	65	65
—	30	40	40	40	40	40
50	50	65	65	65	65	65
50	50	65	65	65	65	65
50	50	65	65	65	65	65
—	—	—	—	—	—	—
50	50	65	65	65	65	65
50	50	65	65	65	65	65
50	50	65	65	65	65	65
—	—	—	—	—	—	—
30	30	30	30	30	30	30
35	35	35	35	35	35	35
40	40	40	40	40	40	40
35/70	35/70	35/70	35/70	35/70	35/70	35/70
35	35	35	35	35	35	35
12500	10000	12500	12500	12500	12500	10000
20000	16000	20000	20000	20000	20000	16000
10000	8000	10000	10000	10000	10000	8000
10000	8000	10000	10000	10000	10000	8000
60	60	60	60	60	60	60
240	280	45	70	110	180	280
420	560	90	140	220	360	560
43	43	43	43	43	43	43
54	54	54	54	54	54	54
48	48	48	48	48	48	48
62	62	62	62	62	62	62
34	34	34	34	34	34	34
38	38	38	38	38	38	38

WWW.TM2A.PT info@tm2a.pt

WWW.TM2A.PT info@tm2a.pt

				IZM32B...08...	IZM32B...10...	IZM32B...12...
<b>General</b>						
Standards				IEC/EN 60947		
Ambient temperature	Storage		°C	-40 - +70 (Devices with LCD display -20 - +70)		
	Operation (open)		°C	-25 - +70 (Devices with LCD display -20 - +70)		
Built-in position						
Utility category				B	B	B
Protection type				IP20, IP54 with protective cover		
Direction of incoming supply				Any		
<b>Main contacts</b>						
Rated operational current = Rated uninterrupted current	$I_n = I_u$	A		800	1000	1250
Rated uninterrupted current at 50 °C <sup>1)</sup>	$I_u$	A		800	1000	1250
Rated uninterrupted current at 60 °C <sup>1)</sup>	$I_u$	A		800	1000	1250
Rated uninterrupted current at 70 °C <sup>1)</sup>	$I_u$	A		800	1000	1250
Rated impulse withstand voltage	$U_{imp}$	V AC		8000	8000	8000
Rated operational voltage	$U_e$	V AC		690	690	690
Use in IT electrical power networks up to U = 440 V	$I_{IT}$	kA		13	13	13
Overvoltage category/pollution degree				III/3		
Rated insulation voltage	$U_i$	V		1000	1000	1000
<b>Switching capacity</b>						
Rated short-circuit making capacity	Up to 440 V 50/60 Hz	$I_{cm}$	kA	137	137	137
	Up to 690 V 50/60 Hz	$I_{cm}$	kA	137	137	137
Rated short-time withstand current 50/60 Hz	t = 1 s	$I_{cw}$	kA	65	65	65
	t = 3 s	$I_{cw}$	kA	-	-	-
Rated short-circuit breaking capacity $I_{cn}$						
IEC/EN 60947 Operating sequence $I_{cu}$ O-t-CO						
	Up to 240 V 50/60 Hz	$I_{cu}$	kA	65	65	65
	Up to 440 V 50/60 Hz	$I_{cu}$	kA	65	65	65
	Up to 690 V 50/60 Hz	$I_{cu}$	kA	65	65	65
	Up to 1100 V 50/60 Hz	$I_{cu}$	kA	-	-	-
IEC/EN 60947 Operating sequence $I_{cs}$ O-t-CO-t-CO						
	Up to 240 V 50/60 Hz	$I_{cs}$	kA	65	65	65
	Up to 440 V 50/60 Hz	$I_{cs}$	kA	65	65	65
	Up to 690 V 50/60 Hz	$I_{cs}$	kA	65	65	65
	Up to 1100 V 50/60 Hz	$I_{cs}$	kA	-	-	-
<b>Switching times</b>						
Total opening delay		ms		30	30	30
Closing delay		ms		35	35	35
Closing delay electrical (via closing release)		ms		40	40	40
Opening delay electrical ( via shunt release / undervoltage release)		ms		35/70	35/70	35/70
Opening delay via trip electronics (non-delayed short-circuit release)		ms		35	35	35
<b>Durability</b>						
Mechanical, without maintenance	Operations			12500	12500	12500
Mechanical, with maintenance	Operations			20000	20000	20000
Electrical, without maintenance	Operations			10000	10000	10000
Electrical, with maintenance	Operations			10000	10000	10000
Maximum operating frequency	Operations/h			60	60	60
Heat dissipation at rated operational current $I_n$ , 3-phase symmetric loading	Fixed	W		40	60	90
	Withdrawable	W		85	130	200
<b>Weight</b>						
Fixed	3 pole	kg		58	58	58
	4 pole	kg		72	72	72
Withdrawable	3 pole	kg		70	70	70
	4 pole	kg		88	88	88
Empty cassette	3 pole	kg		34	34	34
	4 pole	kg		38	38	38

**Notes** <sup>1)</sup> Permissible continuous current for circuit-breakers used at different temperatures within switchgear. The expected internal temperatures can be estimated according to the applicable IEC regulations.

IZM32B...16...	IZM32B...20...	IZM32B...25...	IZM32B...32...	IZM32N...08...	IZM32N...10...	IZM32N...12...
IEC/EN 60947						
-40 - +70 (Devices with LCD display -20 - +70)						
-25 - +70 (Devices with LCD display -20 - +70)						
						
B	B	B	B	B	B	B
IP20, IP54 with protective cover						
Any						
1600	2000	2500	3200	800	1000	1250
1600	2000	2500	3100	800	1000	1250
1600	2000	2500	2800	800	1000	1250
1600	2000	2500	2550	800	1000	1250
8000	8000	8000	8000	8000	8000	8000
690	690	690	690	690	690	690
23	28	39	39	13	13	13
III/3	III/3	III/3	III/3	III/3	III/3	III/3
1000	1000	1000	1000	1000	1000	1000
137	137	137	137	179	179	179
137	137	137	137	179	179	179
65	65	65	65	85	85	85
-	50	50	50	65	65	65
65	65	65	65	85	85	85
65	65	65	65	85	85	85
65	65	65	65	85	85	85
65	65	65	65	85	85	85
65	65	65	65	85	85	85
65	65	65	65	85	85	85
30	30	30	30	30	30	30
35	35	35	35	35	35	35
40	40	40	40	40	40	40
35/70	35/70	35/70	35/70	35/70	35/70	35/70
35	35	35	35	35	35	35
12500	10000	8000	8000	10000	10000	10000
20000	16000	12800	12800	16000	16000	16000
10000	10000	8000	8000	10000	10000	10000
10000	10000	8000	8000	10000	10000	10000
60	60	60	60	60	60	60
150	190	200	320	35	50	70
330	330	500	800	70	95	140
58	63	68	68	68	68	68
72	78	86	86	86	86	86
70	75	86	86	80	80	80
88	94	112	112	102	102	102
34	58	58	60	34	34	34
38	60	60	73	38	38	38



				IZM32N...16...	IZM32N...20...	IZM32N...25...
<b>General</b>						
Standards				IEC/EN 60947		
Ambient temperature		Storage	°C	-40 - +70 (Devices with LCD display -20 - +70)		
		Operation (open)	°C	-25 - +70 (Devices with LCD display -20 - +70)		
Built-in position						
Utility category				B	B	B
Protection type				IP20, IP54 with protective cover		
Direction of incoming supply				Any		
<b>Main contacts</b>						
Rated operational current = Rated uninterrupted current		$I_n = I_u$	A	1600	2000	2500
Rated uninterrupted current at 50 °C <sup>1)</sup>		$I_u$	A	1600	2000	2500
Rated uninterrupted current at 60 °C <sup>1)</sup>		$I_u$	A	1600	2000	2500
Rated uninterrupted current at 70 °C <sup>1)</sup>		$I_u$	A	1600	2000	2500
Rated impulse withstand voltage		$U_{imp}$	V AC	8000	8000	8000
Rated operational voltage		$U_e$	V AC	690	690	690
Use in IT electrical power networks up to U = 440 V		$I_{IT}$	kA	23	28	39
Overvoltage category/pollution degree				III/3	III/3	III/3
Rated insulation voltage		$U_i$	V	1000	1000	1000
<b>Switching capacity</b>						
Rated short-circuit making capacity		Up to 440 V 50/60 Hz	$I_{cm}$	kA	179	179
		Up to 690 V 50/60 Hz	$I_{cm}$	kA	179	179
Rated short-time withstand current 50/60 Hz		t = 1 s	$I_{cw}$	kA	85	85
		t = 3 s	$I_{cw}$	kA	65	65
Rated short-circuit breaking capacity $I_{cn}$						
IEC/EN 60947 Operating sequence $I_{cu}$ 0-t-CO						
		Up to 240 V 50/60 Hz	$I_{cu}$	kA	85	85
		Up to 440 V 50/60 Hz	$I_{cu}$	kA	85	85
		Up to 690 V 50/60 Hz	$I_{cu}$	kA	85	85
		Up to 1100 V 50/60 Hz	$I_{cu}$	kA	-	-
IEC/EN 60947 Operating sequence $I_{cs}$ 0-t-CO-t-CO						
		Up to 240 V 50/60 Hz	$I_{cs}$	kA	85	85
		Up to 440 V 50/60 Hz	$I_{cs}$	kA	85	85
		Up to 690 V 50/60 Hz	$I_{cs}$	kA	85	85
		Up to 1100 V 50/60 Hz	$I_{cs}$	kA	-	-
Switching times						
Total opening delay			ms	30	30	30
Closing delay			ms	35	35	35
Closing delay electrical (via closing release)			ms	40	40	40
Opening delay electrical ( via shunt release / undervoltage release)			ms	35/70	35/70	35/70
Opening delay via trip electronics (non-delayed short-circuit release)			ms	35	35	35
Durability						
Mechanical, without maintenance		Operations		10000	10000	8000
Mechanical, with maintenance		Operations		16000	16000	12800
Electrical, without maintenance		Operations		10000	10000	8000
Electrical, with maintenance		Operations		10000	10000	8000
Maximum operating frequency		Operations/h		60	60	60
Heat dissipation at rated operational current $I_n$		Fixed	W	120	190	200
3-phase symmetric loading		Withdrawable	W	240	380	500
<b>Weight</b>						
Fixed		3 pole	kg	68	68	70
		4 pole	kg	86	86	89
Withdrawable		3 pole	kg	80	80	88
		4 pole	kg	102	102	115
Empty cassette		3 pole	kg	34	34	58
		4 pole	kg	38	38	60

**Notes** <sup>1)</sup> Permissible continuous current for circuit-breakers used at different temperatures within switchgear. The expected internal temperatures can be estimated according to the applicable IEC regulations.

IZM32N...32...	IZM32H...08...	IZM32H...10...	IZM32H...12...	IZM32H...16...	IZM32H...20...	IZM32H...25...
IEC/EN 60947						
-40 - +70 (Devices with LCD display -20 - +70)						
-25 - +70 (Devices with LCD display -20 - +70)						
						
B	B	B	B	B	B	B
IP20, IP54 with protective cover						
Any						
3200	800	1000	1250	1600	2000	2500
3100	800	1000	1250	1600	2000	2500
2800	800	1000	1250	1600	2000	2500
2550	800	1000	1250	1600	2000	2500
8000	8000	8000	8000	8000	8000	8000
690	690	690	690	690	690	690
39	13	13	13	23	28	39
III/3	III/3	III/3	III/3	III/3	III/3	III/3
1000	1000	1000	1000	1000	1000	1000
179	210	210	210	210	210	210
179	179	179	179	179	179	179
85	85	85	85	85	85	85
65	65	65	65	65	65	65
85	100	100	100	100	100	100
85	100	100	100	100	100	100
85	85	85	85	85	85	85
-	-	-	-	-	-	-
85	100	100	100	100	100	100
85	100	100	100	100	100	100
85	85	85	85	85	85	85
-	-	-	-	-	-	-
30	30	30	30	30	30	30
35	35	35	35	35	35	35
40	40	40	40	40	40	40
35/70	35/70	35/70	35/70	35/70	35/70	35/70
35	35	35	35	35	35	35
8000	10000	10000	10000	10000	10000	8000
12800	16000	16000	16000	16000	16000	12800
8000	10000	10000	10000	10000	10000	8000
8000	10000	10000	10000	10000	10000	8000
60	60	60	60	60	60	60
320	30	50	70	120	190	200
800	60	95	140	240	380	500
70	68	68	68	68	68	70
89	86	86	86	86	86	89
88	80	80	80	80	80	88
115	102	102	102	102	102	115
60	34	34	34	34	58	58
73	38	38	38	38	60	60

				IZM32H...32...	IZM32S...	IZM40N...40...
<b>General</b>				IEC/EN 60947		
Standards				-40 - +70 (Devices with LCD display -20 - +70)		
Ambient temperature	Storage		°C	-25 - +70 (Devices with LCD display -20 - +70)		
	Operation (open)		°C			
Built-in position						
Utility category				B	B	B
Protection type				IP20, IP54 with protective cover		
Direction of incoming supply				Any		
<b>Main contacts</b>						
Rated operational current = Rated uninterrupted current		$I_n = I_u$	A	3200	3200	4000
Rated uninterrupted current at 50 °C <sup>1)</sup>		$I_u$	A	3100	3100	4000
Rated uninterrupted current at 60 °C <sup>1)</sup>		$I_u$	A	2800	2800	4000
Rated uninterrupted current at 70 °C <sup>1)</sup>		$I_u$	A	2550	2550	3776
Rated impulse withstand voltage		$U_{imp}$	V AC	8000	8000	12000
Rated operational voltage		$U_e$	V AC	690	1100	690
Use in IT electrical power networks up to U = 440 V		$I_{IT}$	kA	39	-	48
Overvoltage category/pollution degree				III/3	III/3	III/3
Rated insulation voltage		$U_i$	V	1000	1100	1000
<b>Switching capacity</b>						
Rated short-circuit making capacity	Up to 440 V 50/60 Hz	$I_{cm}$	kA	210	210	179
	Up to 690 V 50/60 Hz	$I_{cm}$	kA	179	210	137
Rated short-time withstand current 50/60 Hz	t = 1 s	$I_{cw}$	kA	85	-	85
	t = 3 s	$I_{cw}$	kA	65	-	65
Rated short-circuit breaking capacity $I_{cn}$						
IEC/EN 60947 Operating sequence $I_{cu}$ O-t-CO						
	Up to 240 V 50/60 Hz	$I_{cu}$	kA	100	-	85
	Up to 440 V 50/60 Hz	$I_{cu}$	kA	100	-	85
	Up to 690 V 50/60 Hz	$I_{cu}$	kA	85	-	65
	Up to 1100 V 50/60 Hz	$I_{cu}$	kA	-	25	-
IEC/EN 60947 Operating sequence $I_{cs}$ O-t-CO-t-CO						
	Up to 240 V 50/60 Hz	$I_{cs}$	kA	100	-	85
	Up to 440 V 50/60 Hz	$I_{cs}$	kA	100	-	85
	Up to 690 V 50/60 Hz	$I_{cs}$	kA	85	-	65
	Up to 1100 V 50/60 Hz	$I_{cs}$	kA	-	25	-
<b>Switching times</b>						
Total opening delay			ms	30	30	30
Closing delay			ms	35	35	35
Closing delay electrical (via closing release)			ms	40	40	40
Opening delay electrical (via shunt release / undervoltage release)			ms	35/70	35/70	35/70
Opening delay via trip electronics (non-delayed short-circuit release)			ms	35	35	35
<b>Durability</b>						
Mechanical, without maintenance		Operations		8000	8000	5000
Mechanical, with maintenance		Operations		12800	12800	8000
Electrical, without maintenance		Operations		8000	8000	3000
Electrical, with maintenance		Operations		8000	8000	3000
Maximum operating frequency		Operations/h		60	60	60
Heat dissipation at rated operational current $I_n$ 3-phase symmetric loading	Fixed		W	320	320	560
	Withdrawable		W	800	800	1100
<b>Weight</b>						
Fixed	3 pole		kg	70	70	83
	4 pole		kg	89	89	105
Withdrawable	3 pole		kg	88	88	98
	4 pole		kg	115	115	121
Empty cassette	3 pole		kg	60	60	60
	4 pole		kg	73	73	73

**Notes** <sup>1)</sup> Permissible continuous current for circuit-breakers used at different temperatures within switchgear. The expected internal temperatures can be estimated according to the applicable IEC regulations.

IZM40H...40...	IZM63N...40...	IZM63N...50...	IZM63N...63...	IZM63H...40...	IZM63H...50...	IZM63H...63...
IEC/EN 60947						
-40 - +70 (Devices with LCD display -20 - +70)						
-25 - +70 (Devices with LCD display -20 - +70)						
						
B	B	B	B	B	B	B
IP20, IP54 with protective cover						
Any						
4000	4000	5000	6300	4000	5000	6300
4000	4000	5000	6200	4000	5000	6200
4000	4000	5000	5600	4000	5000	5600
3776	4000	5000	5100	4000	5000	5100
12000	8000	8000	8000	8000	8000	8000
690	690	690	690	690	690	690
48	-	-	-	-	-	-
III/3	III/3	III/3	III/3	III/3	III/3	III/3
1000	1000	1000	1000	1000	1000	1000
210	179	179	179	210	210	210
137	179	179	179	210	210	210
100	85	85	85	100	100	100
65	65	65	65	65	65	65
100	85	85	85	100	100	100
100	85	85	85	100	100	100
65	85	85	85	100	100	100
-	-	-	-	-	-	-
100	85	85	85	100	100	100
100	85	85	85	100	100	100
65	85	85	85	100	100	100
-	-	-	-	-	-	-
30	40	40	40	40	40	40
35	35	35	35	35	35	35
40	40	40	40	40	40	40
35/70	35/70	35/70	35/70	35/70	35/70	35/70
35	35	35	35	35	35	35
5000	5000	5000	5000	5000	5000	5000
8000	8000	8000	8000	8000	8000	8000
3000	3000	3000	3000	3000	3000	3000
3000	3000	3000	3000	3000	3000	3000
60	60	60	60	60	60	60
560	380	400	620	380	400	620
1100	750	1000	1550	750	1000	1550
83	108	125	125	108	125	125
105	145	163	163	145	163	163
98	139	157	157	139	157	157
121	166	200	200	166	200	200
60	60	60	60	60	60	60
73	73	73	73	73	73	73

WWW.TM2A.PT info@tm2a.pt

WWW.TM2A.PT info@tm2a.pt



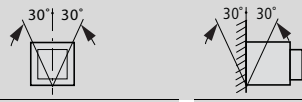

			IN20B...08...	IN20B...10...	IN20B...12...
<b>General</b>					
Standards			IEC/EN 60947		
Ambient temperature					
Storage		°C	-40 - +70		
Operation (open)		°C	-25 - +70		
Built-in position					
Utility category			B	B	B
Protection type			IP20, IP54 with protective cover		
Direction of incoming supply			Any		
<b>Main contacts</b>					
Rated operational current = Rated uninterrupted current	$I_n = I_u$	A	800	1000	1250
Rated uninterrupted current at 50 °C <sup>1)</sup>	$I_u$	A	800	1000	1250
Rated uninterrupted current at 60 °C <sup>1)</sup>	$I_u$	A	800	1000	1100
Rated uninterrupted current at 70 °C <sup>1)</sup>	$I_u$	A	800	1000	1000
Rated impulse withstand voltage	$U_{imp}$	V AC	8000	8000	8000
Rated operational voltage	$U_e$	V AC	690	690	690
Use in IT electrical power networks up to U = 440 V	$I_{IT}$	kA	21	21	21
Use in IT electrical power networks up to U = 690 V	$I_{IT}$	kA	-	-	-
Overvoltage category/pollution degree			III/3	III/3	III/3
Rated insulation voltage	$U_i$	V	1000	1000	1000
<b>Switching capacity</b>					
Rated short-circuit making capacity					
Up to 440 V 50/60 Hz	$I_{cm}$	kA	105	105	105
Up to 690 V 50/60 Hz	$I_{cm}$	kA	105	105	105
Rated short-time withstand current 50/60 Hz					
t = 1 s	$I_{cw}$	kA	50	50	50
t = 3 s	$I_{cw}$	kA	-	-	-
Switching times					
Total opening delay		ms	30	30	30
Closing delay		ms	35	35	35
Closing delay electrical (via closing release)		ms	40	40	40
Opening delay electrical (via shunt release / undervoltage release)		ms	35/70	35/70	35/70
Durability					
Mechanical, without maintenance	Operations		12500	12500	12500
Mechanical, with maintenance	Operations		20000	20000	20000
Electrical, without maintenance	Operations		10000	10000	10000
Electrical, with maintenance	Operations		10000	10000	10000
Maximum operating frequency	Operations/h		60	60	60
Heat dissipation at rated operational current $I_n$ 3-phase symmetric loading					
Fixed		W	60	95	150
Withdrawable		W	110	170	260
<b>Weight</b>					
Fixed					
3 pole		kg	43	43	43
4 pole		kg	54	54	54
Withdrawable					
3 pole		kg	48	48	48
4 pole		kg	62	62	62
Empty cassette					
3 pole		kg	34	34	34
4 pole		kg	38	38	38

**Notes** <sup>1)</sup> Permissible continuous current for circuit-breakers used at different temperatures within switchgear. The expected internal temperatures can be estimated according to the applicable IEC regulations.

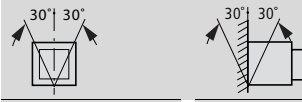
IN20B...16...	IN20B...20...	IN20N...08...	IN20N...10...	IN20N...12...	IN20N...16...	IN20N...20...
IEC/EN 60947						
-40 - +70						
-25 - +70						
						
B	B	B	B	B	B	B
IP20, IP54 with protective cover						
Any						
1600	2000	800	1000	1250	1600	2000
1600	2000	800	1000	1250	1600	2000
1500	1800	800	1000	1100	1500	1800
1350	1650	800	1000	1000	1350	1650
8000	8000	8000	8000	8000	8000	8000
690	690	690	690	690	690	690
23	32	21	21	21	23	32
-	-	-	-	-	-	-
III/3	III/3	III/3	III/3	III/3	III/3	III/3
1000	1000	1000	1000	1000	1000	1000
105	105	143	143	143	143	143
105	105	143	143	143	143	143
50	50	65	65	65	65	65
-	30	40	40	40	40	40
30	30	30	30	30	30	30
35	35	35	35	35	35	35
40	40	40	40	40	40	40
35/70	35/70	35/70	35/70	35/70	35/70	35/70
12500	10000	12500	12500	12500	12500	10000
20000	16000	20000	20000	20000	20000	16000
10000	8000	10000	10000	10000	10000	8000
10000	8000	10000	10000	10000	10000	8000
60	60	60	60	60	60	60
240	280	45	70	110	180	280
420	560	90	140	220	360	560
43	43	43	43	43	43	43
54	54	54	54	54	54	54
48	48	48	48	48	48	48
62	62	62	62	62	62	62
34	34	34	34	34	34	34
38	38	38	38	38	38	38

WWW.TM2A.PT info@tm2a.pt

WWW.TM2A.PT info@tm2a.pt



			IN32B...08...	IN32B...10...	IN32B...12...
<b>General</b>					
Standards	IEC/EN 60947				
Ambient temperature					
Storage	°C		-40 - +70	-40 - +70	-40 - +70
Operation (open)	°C		-25 - +70	-25 - +70	-25 - +70
Built-in position					
Utility category	B				
Protection type	IP20, IP54 with protective cover				
Direction of incoming supply	Any				
<b>Main contacts</b>					
Rated operational current = Rated uninterrupted current	$I_n = I_u$	A	800	1000	1250
Rated uninterrupted current at 50 °C <sup>1)</sup>	$I_u$	A	800	1000	1250
Rated uninterrupted current at 60 °C <sup>1)</sup>	$I_u$	A	800	1000	1250
Rated uninterrupted current at 70 °C <sup>1)</sup>	$I_u$	A	800	1000	1250
Rated impulse withstand voltage	$U_{imp}$	V AC	8000	8000	8000
Rated operational voltage	$U_e$	V AC	690	690	690
Use in IT electrical power networks up to U = 440 V	$I_{IT}$	kA	13	13	13
Overvoltage category/pollution degree					
Rated insulation voltage	$U_i$	V	1000	1000	1000
<b>Switching capacity</b>					
Rated short-circuit making capacity					
Up to 440 V 50/60 Hz	$I_{cm}$	kA	143	143	143
Up to 690 V 50/60 Hz	$I_{cm}$	kA	143	143	143
Rated short-time withstand current 50/60 Hz					
t = 1 s	$I_{cw}$	kA	65	65	65
t = 3 s	$I_{cw}$	kA	-	-	-
Switching times					
Total opening delay		ms	30	30	30
Closing delay		ms	35	35	35
Closing delay electrical (via closing release)		ms	40	40	40
Opening delay electrical (via shunt release / undervoltage release)		ms	35/70	35/70	35/70
Durability					
Mechanical, without maintenance	Operations		12500	12500	12500
Mechanical, with maintenance	Operations		20000	20000	20000
Electrical, without maintenance	Operations		10000	10000	10000
Electrical, with maintenance	Operations		10000	10000	10000
Maximum operating frequency	Operations/h		60	60	60
Heat dissipation at rated operational current $I_n$ 3-phase symmetric loading					
Fixed		W	40	60	90
Withdrawable		W	85	130	200
<b>Weight</b>					
Fixed					
3 pole		kg	58	58	58
4 pole		kg	72	72	72
Withdrawable					
3 pole		kg	70	70	70
4 pole		kg	88	88	88
Empty cassette					
3 pole		kg	34	34	34
4 pole		kg	38	38	38

**Notes** <sup>1)</sup> Permissible continuous current for circuit-breakers used at different temperatures within switchgear. The expected internal temperatures can be estimated according to the applicable IEC regulations.

			IN32B...16...	IN32B...20...	IN32B...25...	IN32B...32...
<b>General</b>						
Standards						
IEC/EN 60947						
Ambient temperature						
-40 - +70						
-25 - +70						
Built-in position						
Utility category						
B						
Protection type						
IP20, IP54 with protective cover						
Direction of incoming supply						
Any						
<b>Main contacts</b>						
1600						
2000						
2500						
3200						
1600						
2000						
2500						
3100						
1600						
2000						
2500						
2800						
1600						
2000						
2500						
2550						
8000						
8000						
8000						
8000						
690						
690						
690						
690						
23						
28						
39						
39						
III/3						
III/3						
III/3						
III/3						
1000						
1000						
1000						
1000						
<b>Switching capacity</b>						
Rated short-circuit making capacity						
143						
143						
143						
143						
Rated short-time withstand current 50/60 Hz						
65						
65						
65						
65						
-						
50						
50						
50						
50						
Switching times						
30						
30						
30						
35						
35						
35						
40						
40						
40						
40						
35/70						
35/70						
35/70						
35/70						
Durability						
12500						
10000						
8000						
8000						
20000						
16000						
12800						
10000						
10000						
8000						
8000						
8000						
8000						
60						
60						
60						
60						
Heat dissipation at rated operational current $I_n$ 3-phase symmetric loading						
150						
190						
200						
320						
330						
330						
500						
800						
<b>Weight</b>						
Fixed						
58						
63						
68						
68						
72						
78						
86						
86						
70						
75						
86						
86						
88						
94						
112						
112						
Empty cassette						
34						
58						
58						
60						
38						
60						
60						
73						

WWW.TM2A.PT info@tm2a.pt

WWW.TM2A.PT info@tm2a.pt



			IN32N...08...	IN32N...10...	IN32N...12...
<b>General</b>					
Standards			IEC/EN 60947		
Ambient temperature					
Storage		°C	-40 - +70		
Operation (open)		°C	-25 - +70		
Built-in position					
Utility category			B		
Protection type			IP20, IP54 with protective cover		
Direction of incoming supply			Any		
<b>Main contacts</b>					
Rated operational current = Rated uninterrupted current	$I_n = I_u$	A	800	1000	1250
Rated uninterrupted current at 50 °C <sup>1)</sup>	$I_u$	A	800	1000	1250
Rated uninterrupted current at 60 °C <sup>1)</sup>	$I_u$	A	800	1000	1250
Rated uninterrupted current at 70 °C <sup>1)</sup>	$I_u$	A	800	1000	1250
Rated impulse withstand voltage	$U_{imp}$	V AC	8000	8000	8000
Rated operational voltage	$U_e$	V AC	690	690	690
Use in IT electrical power networks up to U = 440 V	$I_{IT}$	kA	13	13	13
Overvoltage category/degree of pollution					
Rated insulation voltage	$U_i$	V	1000	1000	1000
<b>Switching capacity</b>					
Rated short-circuit making capacity					
Up to 440 V 50/60 Hz	$I_{cm}$	kA	187	187	187
Up to 690 V 50/60 Hz	$I_{cm}$	kA	187	187	187
Rated short-time withstand current 50/60 Hz					
t = 1 s	$I_{cw}$	kA	85	85	85
t = 3 s	$I_{cw}$	kA	65	65	65
Switching times					
Total opening delay		ms	30	30	30
Closing delay		ms	35	35	35
Closing delay electrical (via closing release)		ms	40	40	40
Opening delay electrical (via shunt release / undervoltage release)		ms	35/70	35/70	35/70
Durability					
Mechanical, without maintenance	Operations		10000	10000	10000
Mechanical, with maintenance	Operations		16000	16000	16000
Electrical, without maintenance	Operations		10000	10000	10000
Electrical, with maintenance	Operations		10000	10000	10000
Maximum operating frequency	Operations/h		60	60	60
Heat dissipation at rated operational current $I_n$ 3-phase symmetric loading					
Fixed		W	35	50	70
Withdrawable		W	70	95	140
<b>Weight</b>					
Fixed					
3 pole		kg	68	68	68
4 pole		kg	86	86	86
Withdrawable					
3 pole		kg	80	80	80
4 pole		kg	102	102	102
Empty cassette					
3 pole		kg	34	34	34
4 pole		kg	38	38	38

Notes <sup>1)</sup> Permissible continuous current for circuit-breakers used at different temperatures within switchgear. The expected internal temperatures can be estimated according to the applicable IEC regulations.

IN32N...16...	IN32N...20...	IN32N...25...	IN32N...32...	IN32S...
IEC/EN 60947				
-40 - +70				
-25 - +70				
B				
IP20, IP54 with protective cover				
Any				
1600	2000	2500	3200	3200
1600	2000	2500	3100	3100
1600	2000	2500	2800	2800
1600	2000	2500	2550	2550
8000	8000	8000	8000	8000
690	690	690	690	690
23	28	39	39	39
Overvoltage category/degree of pollution				
III/3	III/3	III/3	III/3	III/3
1000	1000	1000	1000	1100
<b>Switching capacity</b>				
Rated short-circuit making capacity				
187	187	187	187	53
187	187	187	187	53
Rated short-time withstand current 50/60 Hz				
85	85	85	85	-
65	65	65	65	-
Switching times				
30	30	30	30	30
35	35	35	35	35
40	40	40	40	40
35/70	35/70	35/70	35/70	35/70
Durability				
10000	10000	8000	8000	8000
16000	16000	12800	12800	12800
10000	10000	8000	8000	8000
10000	10000	8000	8000	8000
60	60	60	60	60
Heat dissipation at rated operational current $I_n$ 3-phase symmetric loading				
120	190	200	320	320
240	380	500	800	800
<b>Weight</b>				
Fixed				
68	68	70	70	70
86	86	89	89	89
Withdrawable				
80	80	88	88	88
102	102	115	115	115
Empty cassette				
34	58	58	60	60
38	60	60	73	73

WWW.TM2A.PT info@tm2a.pt

WWW.TM2A.PT info@tm2a.pt

			IN40N...40...	IN40H...40...	IN63N...40...
<b>General</b>					
Standards			IEC/EN 60947		
Ambient temperature					
Storage		°C	-40 - +70	-40 - +70	-40 - +70
Operation (open)		°C	-25 - +70	-25 - +70	-25 - +70
Built-in position					
Utility category			B		
Protection type			IP20, IP54 with protective cover		
Direction of incoming supply			Any		
<b>Main contacts</b>					
Rated operational current = Rated uninterrupted current	$I_n = I_u$	A	4000	4000	4000
Rated uninterrupted current at 50 °C <sup>1)</sup>	$I_u$	A	4000	4000	4000
Rated uninterrupted current at 60 °C <sup>1)</sup>	$I_u$	A	4000	4000	4000
Rated uninterrupted current at 70 °C <sup>1)</sup>	$I_u$	A	3776	3776	4000
Rated impulse withstand voltage	$U_{imp}$	V AC	12000	12000	8000
Rated operational voltage	$U_e$	V AC	690	690	690
Use in IT electrical power networks up to U = 440 V	$I_{IT}$	kA	48	48	-
Use in IT electrical power networks up to U = 690 V	$I_{IT}$	kA	-	-	-
Overvoltage category/pollution degree			III/3	III/3	III/3
Rated insulation voltage	$U_i$	V	1000	1000	1000
<b>Switching capacity</b>					
Rated short-circuit making capacity					
Up to 440 V 50/60 Hz	$I_{cm}$	kA	187	220	187
Up to 690 V 50/60 Hz	$I_{cm}$	kA	187	220	187
Rated short-time withstand current 50/60 Hz					
t = 1 s	$I_{cw}$	kA	85	100	85
t = 3 s	$I_{cw}$	kA	65	65	65
Switching times					
Total opening delay		ms	30	30	40
Closing delay		ms	35	35	35
Closing delay electrical (via closing release)		ms	40	40	40
Opening delay electrical (via shunt release / undervoltage release)		ms	35/70	35/70	35/70
Durability					
Mechanical, without maintenance	Operations		5000	5000	5000
Mechanical, with maintenance	Operations		8000	8000	8000
Electrical, without maintenance	Operations		3000	3000	3000
Electrical, with maintenance	Operations		3000	3000	3000
Maximum operating frequency	Operations/h		60	60	60
Heat dissipation at rated operational current $I_n$ 3-phase symmetric loading					
Fixed		W	560	560	380
Withdrawable		W	1100	1100	750
<b>Weight</b>					
Fixed					
3 pole		kg	83	83	108
4 pole		kg	105	105	145
Withdrawable					
3 pole		kg	98	98	139
4 pole		kg	121	121	166
Empty cassette					
3 pole		kg	55	55	103
4 pole		kg	64	64	103

Notes

<sup>1)</sup> Permissible continuous current for circuit-breakers used at different temperatures within switchgear. The expected internal temperatures can be estimated according to the applicable IEC regulations.

	IN63N...50...	IN63N...63...	IN63H...40...	IN63H...50...	IN63H...63...
IEC/EN 60947					
-40 - +70					
-25 - +70					
B					
IP20, IP54 with protective cover					
Any					
	5000	6300	4000	5000	6300
	5000	6200	4000	5000	6200
	5000	5600	4000	5000	5600
	5000	5100	4000	5000	5100
	8000	8000	8000	8000	8000
	690	690	690	690	690
	-	-	-	-	-
	-	-	-	-	-
	III/3	III/3	III/3	III/3	III/3
	1000	1000	1000	1000	1000
	187	187	220	220	220
	187	187	220	220	220
	85	85	100	100	100
	65	65	65	65	65
	40	40	40	40	40
	35	35	35	35	35
	40	40	40	40	40
	35/70	35/70	35/70	35/70	35/70
	5000	5000	5000	5000	5000
	8000	8000	8000	8000	8000
	3000	3000	3000	3000	3000
	3000	3000	3000	3000	3000
	60	60	60	60	60
	400	620	380	400	620
	1000	1550	750	1000	1550
	125	125	108	125	125
	163	163	145	163	163
	157	157	139	157	157
	200	200	166	200	200
	103	103	103	103	103
	103	103	103	103	103



# 18/116 IZM circuit-breakers, IN switch-disconnectors

Accessories for IZM26

**IZM-AS, IZM-OTS, IZM-CS, IZM-S...**

			Auxiliary contact, overload trip switch and cell signalling switch				
			IZM-AS...	IZM-OTS	IZM-CS...		
<b>Rated breaking capacity</b>							
Inductive load							
250 V AC	A		10	10	10		
125 V DC	A		0.5	0.5	0.5		
250 V DC	A		0.25	0.25	0.25		
			<b>Voltage releases</b>				
			IZM-ST24DC IZM-ST24DC	IZM-ST48DC IZM-ST48DC	IZM-ST60DC	IZM-ST110AD IZM-ST110AD	IZM-ST230AD IZM-ST230AD
<b>Rated control voltage</b>							
AC 50/60 Hz	U <sub>s</sub>	V	–	–	–	110 - 127	208 - 240
DC	U <sub>s</sub>	V	24	48	60	110 - 125	220 - 250
<b>Power consumption</b>							
AC		VA	–	–	–	(pick-up 450)	(pick-up 450)
DC		W	(pick-up 250)	(pick-up 250)	(pick-up 250)	(pick-up 450)	(pick-up 450)
<b>Response time of the circuit-breaker with U<sub>s</sub></b>			35	35	35	35	35
<b>Operating range</b>							
Drop-out voltage							
AC operated 50/60 Hz	Drop-out	x U <sub>c</sub>	–	–	–	–	–
pick-up voltage							
	pick-up	x U <sub>c</sub>	Acc. to IEC standard	Acc. to IEC standard	Acc. to IEC standard	Acc. to IEC standard	Acc. to IEC standard
			<b>Closing releases</b>				
			IZM-SR24DC	IZM-SR48DC	IZM-SR60DC	IZM-SR110AD	IZM-SR230AD
<b>Rated control voltage</b>							
AC 50/60 Hz	U <sub>s</sub>	V	–	–	–	110 - 127	208 - 240
DC	U <sub>s</sub>	V	24	48	60	110 - 125	220 - 250
<b>Power consumption</b>							
AC		VA	–	–	–	(pick-up 450)	(pick-up 450)
DC		W	(pick-up 250)	(pick-up 250)	(pick-up 250)	(pick-up 450)	(pick-up 450)
<b>Response time of the circuit-breaker with U<sub>s</sub></b>			40	40	40	40	40
<b>Operating range</b>							
Drop-out voltage							
AC operated 50/60 Hz	Drop-out	x U <sub>c</sub>	–	–	–	–	–
pick-up voltage							
	pick-up	x U <sub>c</sub>	Acc. to IEC standard	Acc. to IEC standard	Acc. to IEC standard	Acc. to IEC standard	Acc. to IEC standard

WWW.TM2A.PT info@tm2a.pt

WWW.TM2A.PT info@tm2a.pt



			Under-voltage releases			
			IZM-UVR24DC	IZM-UVR32DC	IZM-UVR48DC	IZM-UVR60DC
<b>Rated control voltage</b>						
AC 50/60 Hz	$U_s$	V	–	–	–	–
DC	$U_s$	V	24	32	48	60
<b>Power consumption</b>						
AC		VA	–	–	–	–
DC		W	18 (pick-up 250)	15 (pick-up 275)	18 (pick-up 275)	18 (pick-up 275)
<b>Response time of the circuit-breaker with <math>U_s</math></b>		ms	70	70	70	70
<b>Operating range</b>						
Drop-out voltage						
AC operated 50/60 Hz	Drop-out	$x U_c$	Acc. to IEC standard	Acc. to IEC standard	Acc. to IEC standard	Acc. to IEC standard
pick-up voltage						
	pick-up	$x U_c$	Acc. to IEC standard	Acc. to IEC standard	Acc. to IEC standard	Acc. to IEC standard

			Under-voltage releases				
			IZM-UVR110AC	IZM-UVR110DC	IZM-UVR220DC	IZM-UVR230AC	IZM-UVR400AC
<b>Rated control voltage</b>							
AC 50/60 Hz	$U_s$	V	110 - 127	–	–	208 - 240	380 - 415
DC	$U_s$	V	–	110 - 125	220 - 250	–	–
<b>Power consumption</b>							
AC		VA	10 (pick-up 450)	–	–	10 (pick-up 400)	10 (pick-up 480)
DC		W	–	10 (pick-up 450)	10 (pick-up 450)	–	–
<b>Response time of the circuit-breaker with <math>U_s</math></b>		ms	70	70	70	70	70
<b>Operating range</b>							
Drop-out voltage							
AC operated 50/60 Hz	Drop-out	$x U_c$	Acc. to IEC standard	Acc. to IEC standard	Acc. to IEC standard	Acc. to IEC standard	Acc. to IEC standard
pick-up voltage							
	pick-up	$x U_c$	Acc. to IEC standard	Acc. to IEC standard	Acc. to IEC standard	Acc. to IEC standard	Acc. to IEC standard

			Motor operator						
			IZM-M24DC	IZM-M48DC	IZM-M60DC	IZM-M110DC	IZM-M220DC	IZM-M110AC	IZM-M230AC
<b>Rated control voltage</b>									
AC 50/60 Hz	$U_s$	V	–	–	–	–	–	110 - 127	208 - 240
DC	$U_s$	V	24	48	60	110 - 125	220 - 250	–	–
<b>Necessary time required for charging of the spring-operated stored energy mechanism at <math>1 \times U_s</math></b>		s	5	5	5	5	5	5	5
<b>Rated operational current</b>	$I_n$	A	12	5	5	2	1	2	1
<b>Starting current</b>		A	36	25	25	12	6	12	6
<b>Power consumption</b>									
AC 50/60 Hz		VA	300	250	250	250	250	250	250
DC		W	300	250	250	250	250	250	250



	IZMX-PCAM	IZMX-MCAM	IZM-PMINT	IZM-MMINT
<b>General</b>				
Dimensions (W x H x D)	24 x 105 x 80 mm	24 x 105 x 80 mm	91 x 111 x 88 mm	92 x 111 x 88 mm
Mounting	Auxiliary contact strip or 35 mm top-hat rail	Auxiliary contact strip or 35 mm top-hat rail	DIN rail (top hat rail) 35 mm	DIN rail (top hat rail) 35 mm
Protection type	IP20	IP20	IP20	IP20
Mounting position	–	–	horizontal	horizontal
Power supply	24 V DC	24 V DC	24 - 150 V DC or 100 - 240 V AC (50/60 Hz)	24 - 125 V DC or 120 V AC (50/60 Hz)
LED indicators	DP Tx Rx Status	Modbus Tx Rx Status	DP Status INCOM Rx Tx Status	Modbus Tx Rx INCOM Rx Tx Status
<b>Network</b>				
INCOM	–	–	Plug-in screw terminals	Plug-in screw terminals
PROFIBUS	SUB-D 9-pole, socket	–	SUB-D 9-pole, socket	–
Modbus	–	Plug-in screw terminals	–	Plug-in screw terminals
Function	Slave	Slave	Slave	Slave
Interface	RS484	RS485	RS484	RS485
Protocol	PROFIBUS-DP	Modbus-RTU	PROFIBUS-DP	Modbus-RTU
Baud rate	Automatic search up to 12 MBit/s	1200/4800/9600/19200 Bit/s, adjustable via Digitrip	Automatic search up to 12 MBit/s	1200/9600/19200 bits/s, adjustable through coding switch
Bus terminating resistors	In plug as required	121 Ω, externally switch- able	In plug as required	121 Ω, activated through coding switch
	INCOM <sup>1)</sup>	–	100 Ω, activated through coding switch	100 Ω, activated through coding switch
Bus addresses	1 - 127, can be set through Digitrip	1 - 247, can be set through Digitrip	1 - 127	1 - 127
	Number of IZM26 devices on INCOM	–	1	32
Maximum distance	2.4 km	1.2 km	2.4 km	1.2 km
	INCOM	–	3	3
Supported functions	Cyclical data transfer	Function code: 03 = read register 04 = read word variables 08 = connection test, 16 = write register	Cyclical data transfer	Function code: 03 = read register 04 = read word variables 08 = connection test, 16 = write register

**Notes**<sup>1)</sup> INCOM = system bus (communication connection between Digitrip and fieldbus module)

**IN20, IZM20 Fixed mounted**

IN20...F, IZM20...F

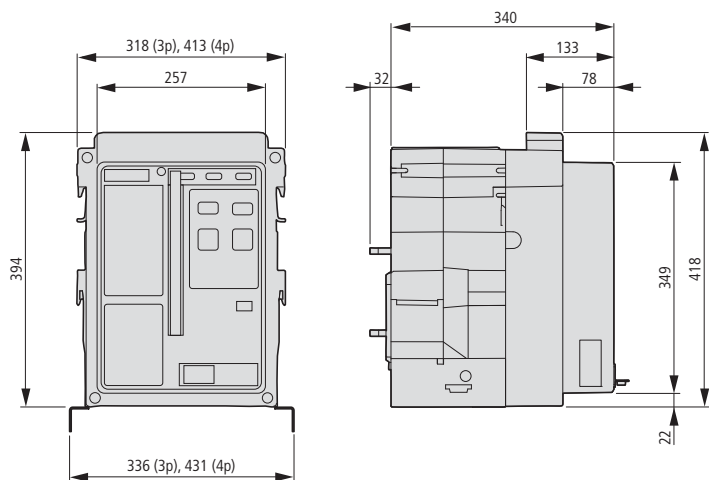

**IN20, IZM20 Withdrawable units**

IN20...W, IZM20...W

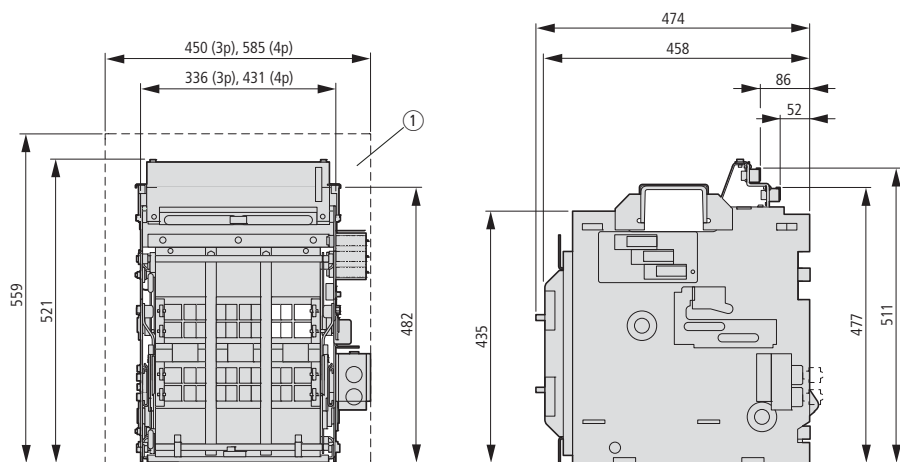

**IN32, IZM32 Fixed mounted**

IN32...F, IZM32...F...

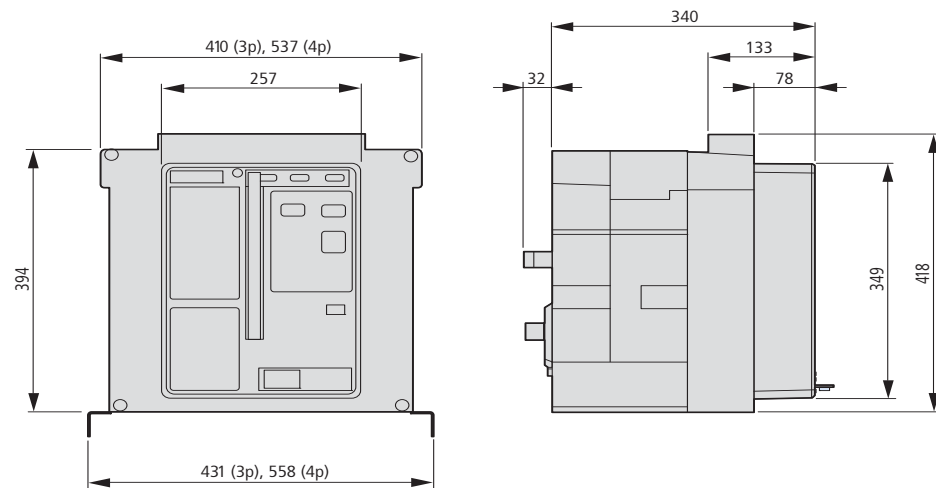

① Recommended minimum enclosure size (not shown to scale)

WWW.TM2A.PT info@tm2a.pt

WWW.TM2A.PT info@tm2a.pt





**IZM26, IN26**

**IN32, IZM32 Withdrawable units**

IN32...W, IZM32...W...

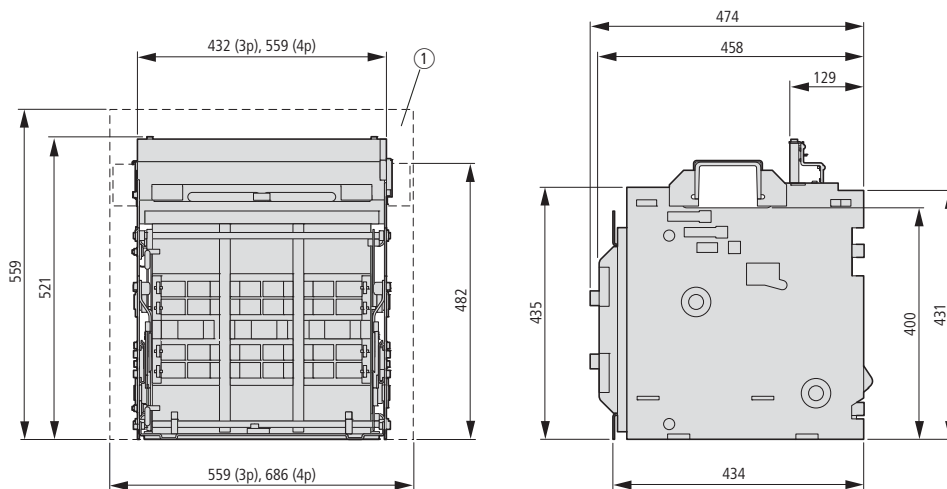

**IN40, IZM40 Fixed mounted**

IN40...F, IZM40...F

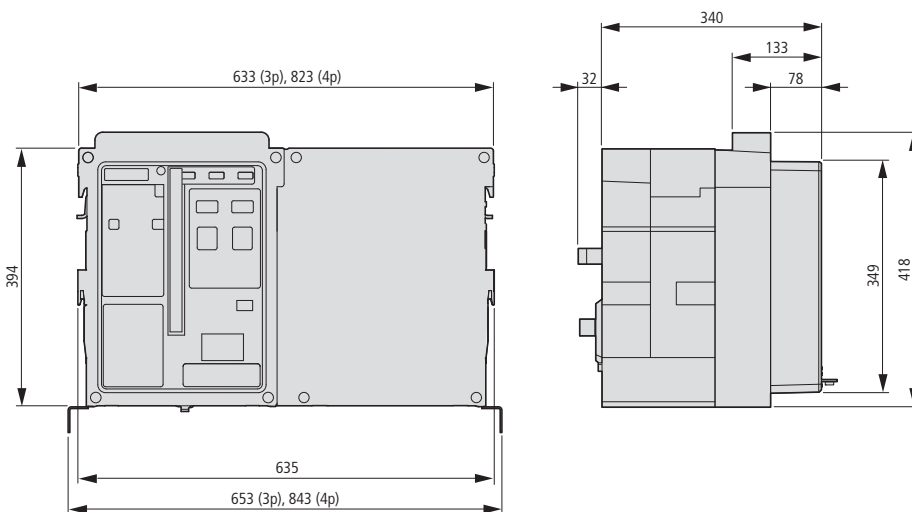

**IN40, IZM40 Withdrawable units**

IN40...W, IZM40...W

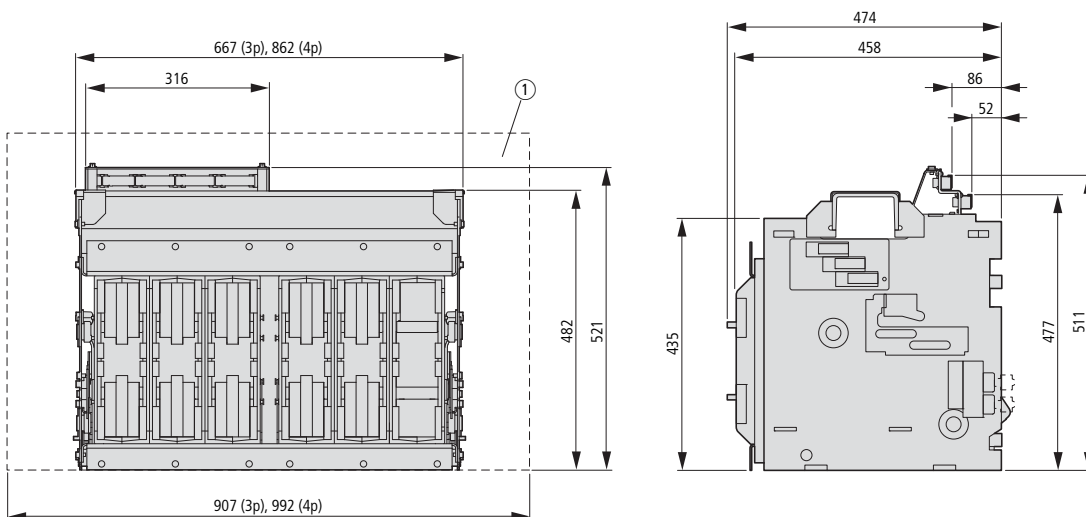

① Recommended minimum enclosure size (not shown to scale)

**IN63, IZM63 Fixed mounted**

IN63...F, IZM63...F

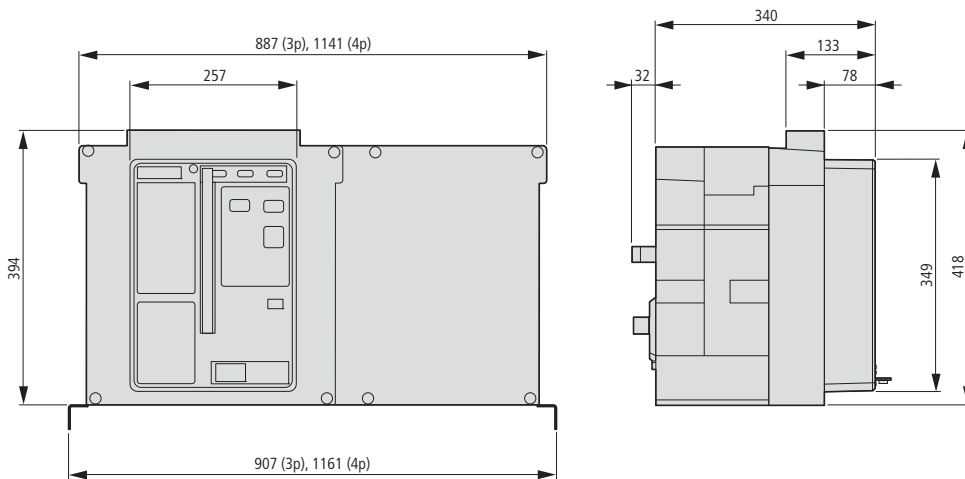

**IN63, IZM63 Withdrawable units**

IN63...W, IZM63...W

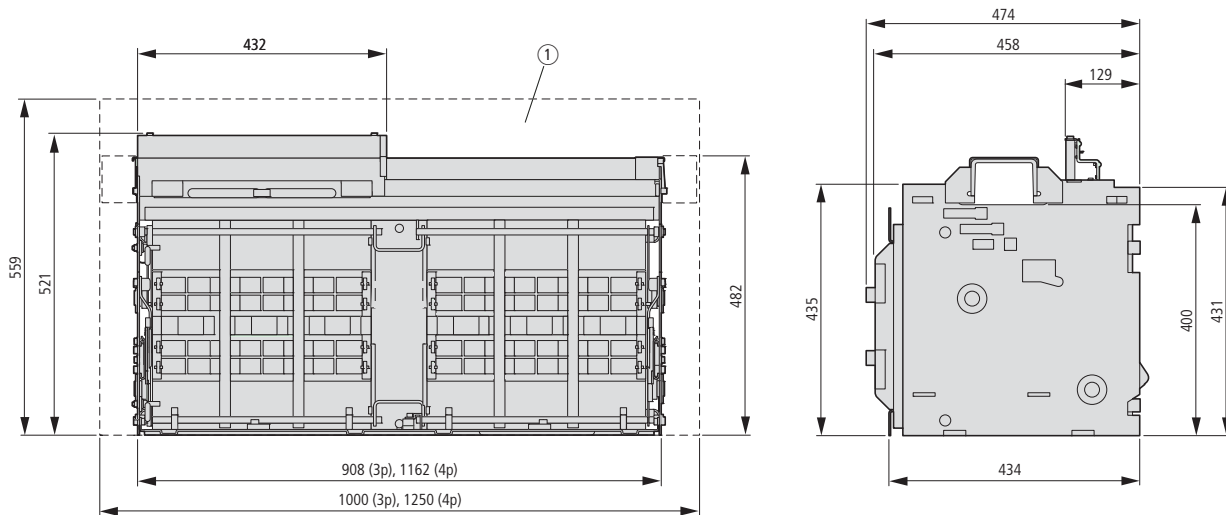

① Recommended minimum enclosure size (not shown to scale)

WWW.TM2A.PT info@tm2a.pt

WWW.TM2A.PT info@tm2a.pt



**Recommended safety clearances**

The following information about safety distances is intended to provide a guideline for the installation of circuit-breakers in an enclosure.

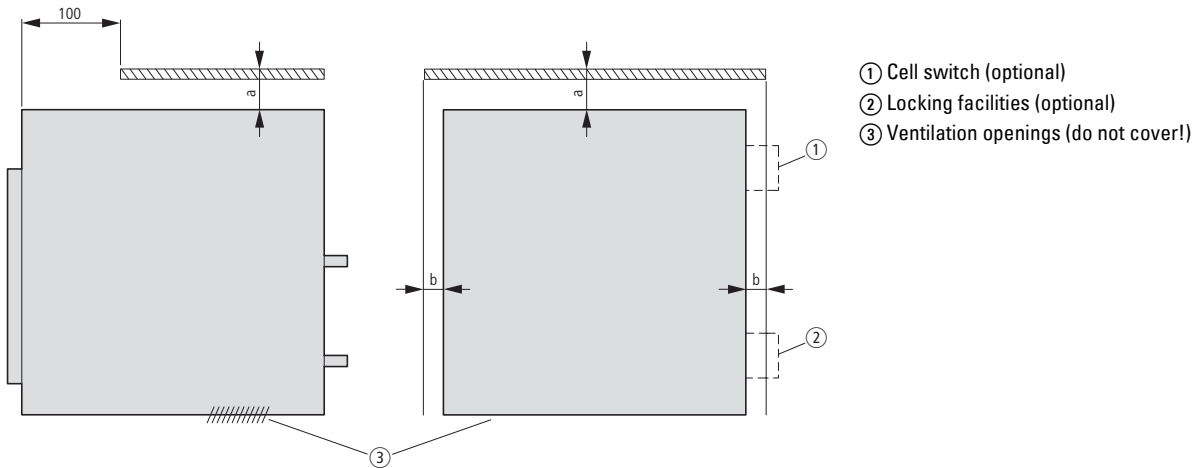

- ① Cell switch (optional)
- ② Locking facilities (optional)
- ③ Ventilation openings (do not cover!)

Enclosure clearance		To insulated surface	To grounded metal surface	With cell switch or locking facilities
		mm	mm	mm
Withdrawable units	a	0	0	0
	b	25	25	25/75
Fixed mounted	a	150	250	–
	b	30	70	–

**Recommended enclosure clearance and ventilation**

The illustration shows a typical enclosure. The table below lists the associated minimum distances between enclosures and ventilation openings. This information is intended as a guideline for constructing a suitable circuit-breaker enclosure.

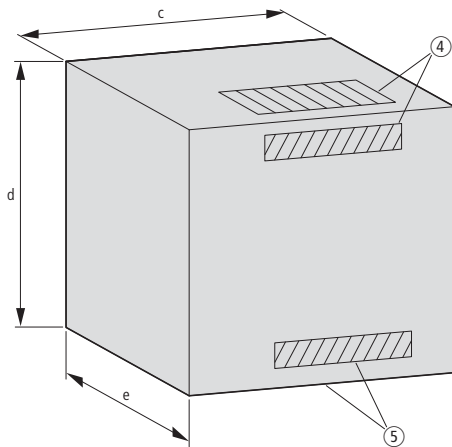

Width	Width of cassette + 75 mm
Height	550 mm
Depth	450 mm (front control panel bay)
Ventilation holes	160 cm <sup>2</sup> (800 - 3200 A) 320 cm <sup>2</sup> (4000 - 6300 A)

- ④ Top or rear vent
- ⑤ Rear or lower vent



WWW.TM2A.PT info@tm2a.pt

WWW.TM2A.PT info@tm2a.pt

