

Linear actuators CLA Series

3.2 TECHNICAL DATA - acme screw linear actuators CLA Series

SIZE		CLA 30	CLA 40	CLA 50	
Push rod diameter	[mm]	35	40	50	
Outer tube diameter	[mm]	55	60	70	
Front attachment diameter	[mm]	14	20	30	
Rear attachment diameter	[mm]	14	20	30	
Attachment for IEC standard motor (flange and hollow shaft)		63 B14	71 B14	71 B14	
Attachment for IEC standard motor (flange adapter + coupling)		—	—	80 B14	
Max. dynamic load	[N]	10 000	12 000	25 000	
Max. static load	pull [N]	10 000	12 000	25 000	
	push [N]	12 000	15 000	25 000	
Ratio	RV	1 : 4 (4 : 16)	1 : 5 (4 : 20)	1 : 5 (4 : 20)	
	RN	1 : 16 (2 : 32)	1 : 20	1 : 20	
	RL	1 : 24	1 : 25	1 : 25	
	RXL	1 : 34	1 : 55	1 : 55	
1-start acme screw		Tr 18×4	Tr 22×5	Tr 30×6	
Linear travel [mm] for 1 input shaft revolution	Ratio				
	RV1	1	1	1.2	
	RN1	0.25	0.25	0.3	
	RL1	0.17	0.2	0.24	
	RXL1	0.12	0.09	0.11	
2-start acme screw		Tr 18×8 (P4)	Tr 22×10 (P5)	Tr 30×12 (P6)	
Linear travel [mm] for 1 input shaft revolution	Ratio				
	RV2	2	2	2.4	
	RN2	0.5	0.5	0.6	
	RL2	0.33	0.4	0.28	
	RXL2	0.24	0.18	0.22	
Mass (actuator 100 mm stroke length, without motor, with lubricant)		[kg]	3.8	6.5	16
Extra-mass for each additional 100 mm stroke length		[kg]	0.8	0.8	2

Linear actuators CLA Series

ACME SCREW LINEAR ACTUATORS CLA Series with AC 3-PHASE MOTOR
 PERFORMANCE with: Duty Cycle $F_i = 30\%$ over 10 min at ambient temperature 25 °C

LINEAR SPEED [mm/s]	DYNAMIC LOAD [N]	RATIO	MOTOR: POWER [kW] — N° of POLES SPEED [rpm]	SELF-LOCKING COEFFICIENT
CLA 30				
46	2500 ¹⁾	RV1	0.25 kW 2-pole 2800	0.25
23	5200 ¹⁾	RN2	0.25 kW 2-pole 2800	0.28
15	6700 ¹⁾	RL2	0.25 kW 2-pole 2800	0.22
11	8500 ¹⁾	RXL2	0.25 kW 2-pole 2800	0.18
7.5	9700 ¹⁾	RL1	0.25 kW 2-pole 2800	0.16
5.5	10000 ²⁾	RXL1	0.25 kW 2-pole 2800	0.13
4	10000 ²⁾	RL1	0.18 kW 4-pole 1400	0.16
2.7	10000 ²⁾	RXL1	0.18 kW 4-pole 1400	0.13
CLA 40				
46	5400 ¹⁾	RV1	0.55 kW 2-pole 2800	0.26
23	10500 ¹⁾	RN2	0.55 kW 2-pole 2800	0.25
18	12000 ²⁾	RL2	0.55 kW 2-pole 2800	0.24
11	12000 ²⁾	RN1	0.55 kW 2-pole 2800	0.18
8.5	12000 ²⁾	RXL2	0.55 kW 2-pole 2800	0.17
5.5	12000 ²⁾	RN1	0.37 kW 4-pole 1400	0.18
4.5	12000 ²⁾	RL1	0.37 kW 4-pole 1400	0.17
2.1	12000 ²⁾	RXL1	0.37 kW 4-pole 1400	0.08
CLA 50				
56	9300 ¹⁾	RV1	1.1 kW 2-pole 2800	0.24
28	17900 ¹⁾	RN2	1.1 kW 2-pole 2800	0.23
22	20800 ¹⁾	RL2	1.1 kW 2-pole 2800	0.22
14	25000 ²⁾	RN1	1.1 kW 2-pole 2800	0.16
11	25000 ²⁾	RL1	1.1 kW 2-pole 2800	0.15
7	25000 ²⁾	RN1	0.75 kW 4-pole 1400	0.16
5.5	25000 ²⁾	RL1	0.75 kW 4-pole 1400	0.15
2.5	25000 ²⁾	RXL1	0.37 kW 4-pole 1400	0.08

ACME SCREW LINEAR ACTUATORS CLA Series with AC 1-PHASE MOTOR
 PERFORMANCE with: Duty Cycle $F_i = 30\%$ over 10 min at ambient temperature 25 °C

LINEAR SPEED [mm/s]	DYNAMIC LOAD [N]	RATIO	MOTOR: POWER [kW] — N° of POLES SPEED [rpm]	SELF-LOCKING COEFFICIENT
CLA 30				
46	2350 ¹⁾	RV1	0.25 kW 2-pole 2800	0.25
23	4800 ¹⁾	RN2	0.25 kW 2-pole 2800	0.28
15	6300 ¹⁾	RL2	0.25 kW 2-pole 2800	0.22
11	8000 ¹⁾	RXL2	0.25 kW 2-pole 2800	0.18
7.5	9200 ¹⁾	RL1	0.25 kW 2-pole 2800	0.16
5.5	10000 ²⁾	RXL1	0.25 kW 2-pole 2800	0.13
4	10000 ²⁾	RL1	0.18 kW 4-pole 1400	0.16
2.7	10000 ²⁾	RXL1	0.18 kW 4-pole 1400	0.13
CLA 40				
46	5400 ¹⁾	RV1	0.55 kW 2-pole 2800	0.26
23	10000 ¹⁾	RN2	0.55 kW 2-pole 2800	0.25
18	12000 ²⁾	RL2	0.55 kW 2-pole 2800	0.24
11	12000 ²⁾	RN1	0.55 kW 2-pole 2800	0.18
8.5	12000 ²⁾	RXL2	0.55 kW 2-pole 2800	0.12
5.5	12000 ²⁾	RN1	0.37 kW 4-pole 1400	0.18
4.5	12000 ²⁾	RL1	0.37 kW 4-pole 1400	0.17
2.1	12000 ²⁾	RXL1	0.37 kW 4-pole 1400	0.08

Linear actuators CLA Series

3.4 OVERALL DIMENSIONS

ACME SCREW LINEAR ACTUATORS CLA Series, size 30 – 40
AC 3-phase or 1-phase MOTOR

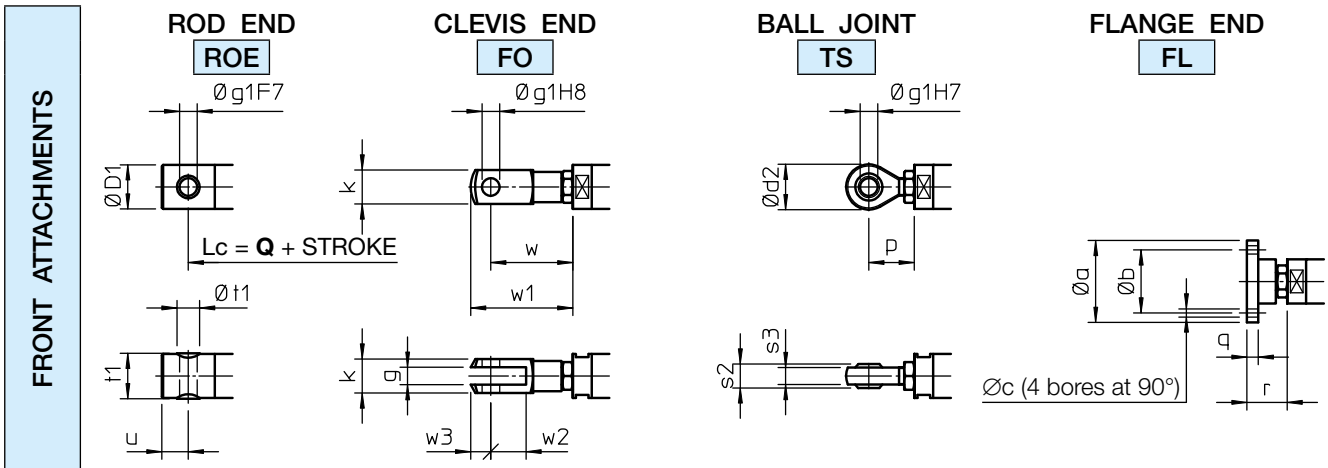
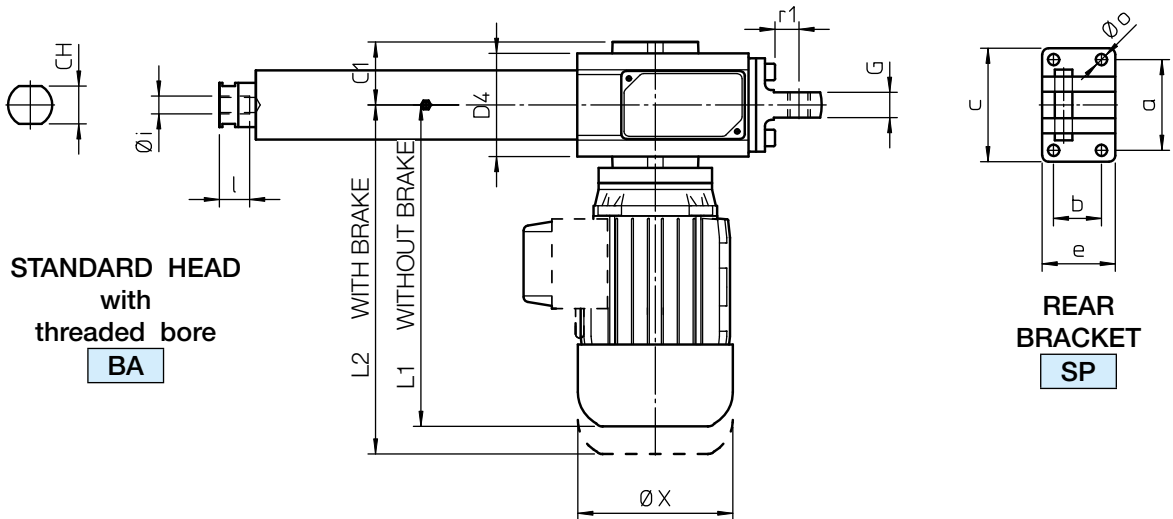
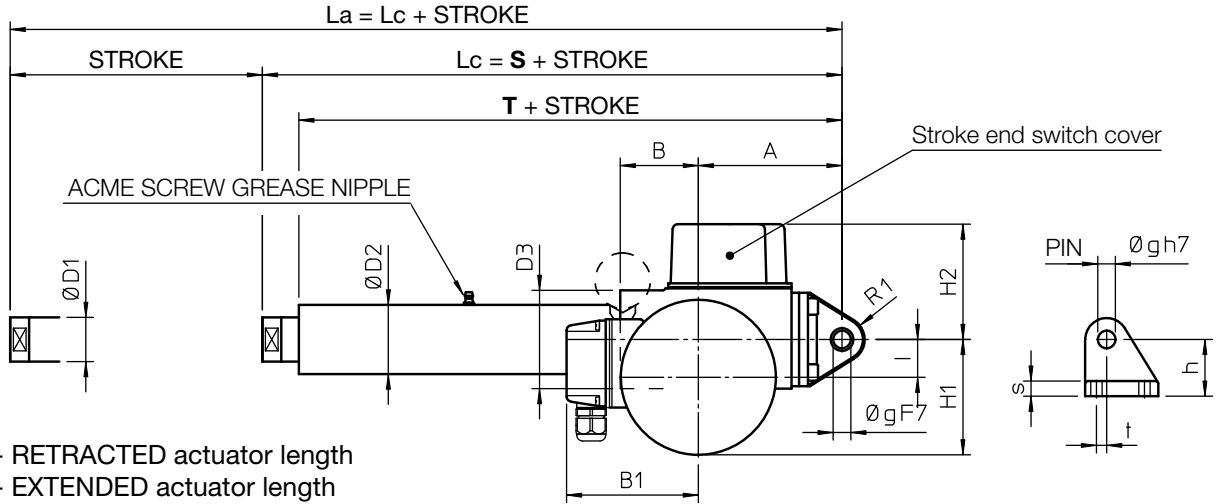

Linear actuators CLA Series

3.4 OVERALL DIMENSIONS

ACME SCREW LINEAR ACTUATORS CLA Series, size 30 – 40 AC 3-phase or 1-phase MOTOR

	STROKE CODE	C...	S	T	Q
CLA 30	STROKE [mm] = STROKE CODE	...	260	231	266
CLA 40			304	266	316

ACTUATOR with FC in STANDARD execution	MAX. stroke [mm]
CLA 30 R_1	500
CLA 30 R_2	800
CLA 40 R_1	600
CLA 40 R_2	800

NOTE: Greater stroke lengths available on request.

For stroke lengths longer than 800 mm it is necessary to increase the guided length between push rod and outer tube to avoid axial backlash. Dimensions **S**, **T** and **Q** shall be considered increased by 200 mm for stroke lengths up to 1500 mm.

	A	B	B1	C1	CH	∅ D1	∅ D2	D3	D4	G	H1	H2	I	L1	L2
CLA 30	114	62	115	54	30	35	55	78	82	20	92	92	30	255	291
CLA 40	128.5	78	124	61	36	40	60	92	103	24	111	99	40	284	373

	R1	∅ X	a	b	c	e	∅ g	h	∅ i	l	∅ o	r1	s	t
CLA 30	18	123	72	38	90	58	14	45	M14×2	24	9	20	12	8
CLA 40	28	150	85	55	110	81	20	58	M20×1.5	27	11	32	15	15

FRONT ATTACHMENT Dimensions

	∅ a	∅ b	∅ c	∅ D1	∅ d2	g	∅ g1	k	p	p1
CLA 30	65	50	6.5	35	36	14	14	27	36	54
CLA 40	80	60	8.5	40	50	20	20	40	53	78

	q	r	s2	s3	t1	∅ t1	u	w	w1	w2	w3
CLA 30	9	32	19	14	36	18	21	65	81	28	16
CLA 40	10	42	25	18	42	25	27	90	115	40	25