

Linear actuators ATL Series

2.2 TECHNICAL DATA - acme screw linear actuators ATL Series

SIZE		ATL 20	ATL 25	ATL 28	ATL 30	ATL 40	
Push rod diameter	[mm]	25	30	30	35	40	
Outer tube diameter	[mm]	36	45	45	55	60	
Front attachment diameter	[mm]	10	12	12	14	20	
Rear attachment diameter	[mm]	12	12	12	14	20	
Input solid shaft diameter	[mm]	9	9	9	10	14	
Attachment for IEC standard motor (flange and hollow shaft)		56 B14	56 B14	63 B14	63 B14	71 B14	
Attachment for IEC standard motor (flange adapter + coupling)		—	—	—	—	—	
Max. dynamic load	[N]	4 000	6 000	8 000	10 000	12 000	
Max. static load	pull [N]	4 000	6 000	8 000	10 000	12 000	
	push [N]	6 000	8 000	10 000	12 000	15 000	
Ratio	RH	1 : 4 (5 : 20)	1 : 4 (5 : 20)	1 : 4 (5 : 20)	—	—	
	RV	1 : 6.25 (4 : 25)	1 : 6.25 (4 : 25)	1 : 6.25 (4 : 25)	1 : 4 (4 : 16)	1 : 5 (4 : 20)	
	RN	1 : 12.5 (2 : 25)	1 : 12.5 (2 : 25)	1 : 12.5 (2 : 25)	1 : 16 (2 : 32)	1 : 20	
	RL	1 : 25	1 : 25	1 : 25	1 : 24	1 : 25	
	RXL	1 : 50	1 : 50	1 : 50	1 : 34	1 : 55	
1-start acme screw		Tr 13.5×3	Tr 16×4	Tr 16×4	Tr 18×4	Tr 22×5	
Linear travel [mm] for 1 input shaft revolution	Ratio	RH1	0.75	1	1	—	—
		RV1	0.48	0.64	0.64	1	1
		RN1	0.24	0.32	0.32	0.25	0.25
		RL1	0.12	0.16	0.16	0.17	0.2
		RXL1	0.06	0.08	0.08	0.12	0.09
2-start acme screw		Tr 14×8 (P4)	Tr 16×8 (P4)	Tr 16×8 (P4)	Tr 18×8 (P4)	Tr 22×10 (P5)	
Linear travel [mm] for 1 input shaft revolution	Ratio	RH2	2	2	2	—	—
		RV2	1.28	1.28	1.28	2	2
		RN2	0.64	0.64	0.64	0.5	0.5
		RL2	0.32	0.32	0.32	0.33	0.4
		RXL2	0.16	0.16	0.16	0.24	0.18
Mass (actuator 100 mm stroke length, without motor, with lubricant)	[kg]	2.2	2.5	2.5	3.8	6.5	
Extra-mass for each additional 100 mm stroke length	[kg]	0.3	0.5	0.5	0.8	0.8	

Linear actuators ATL Series

ACME SCREW LINEAR ACTUATORS ATL Series with AC 3-PHASE MOTOR
 PERFORMANCE with: Duty Cycle $F_i = 30\%$ over 10 min at ambient temperature 25 °C

LINEAR SPEED [mm/s]	DYNAMIC LOAD [N]	RATIO	MOTOR: POWER [kW] – N° of POLES SPEED [rpm]	SELF-LOCKING COEFFICIENT
ATL 20				
93	600 ¹⁾	RH2	0.12 kW 2-pole 2800	0.40
60	1000 ¹⁾	RV2	0.12 kW 2-pole 2800	0.41
46	850 ¹⁾	RH2	0.09 kW 4-pole 1400	0.40
35	1100 ¹⁾	RH1	0.12 kW 2-pole 2800	0.25
30	1750 ¹⁾	RN2	0.12 kW 2-pole 2800	0.35
22	1500 ¹⁾	RV1	0.12 kW 2-pole 2800	0.25
15	3000 ¹⁾	RL2	0.12 kW 2-pole 2800	0.27
11	4000 ¹⁾²⁾	RN1	0.12 kW 2-pole 2800	0.22
7.5	4000 ²⁾	RL2	0.09 kW 4-pole 1400	0.27
5.5	4000 ²⁾	RL1	0.12 kW 2-pole 2800	0.16
2.8	4000 ²⁾	RL1	0.09 kW 4-pole 1400	0.16
1.4	4000 ²⁾	RXL1	0.09 kW 4-pole 1400	0.11
ATL 25				
93	830 ¹⁾	RH2	0.12 kW 2-pole 2800	0.38
60	1250 ¹⁾	RV2	0.12 kW 2-pole 2800	0.38
46	1300 ¹⁾	RH1	0.12 kW 2-pole 2800	0.27
30	2200 ¹⁾	RN2	0.12 kW 2-pole 2800	0.33
23	1650 ¹⁾	RH1	0.09 kW 4-pole 1400	0.27
15	3750 ¹⁾	RL2	0.12 kW 2-pole 2800	0.25
7.5	5550 ¹⁾	RL1	0.12 kW 2-pole 2800	0.18
3.5	6000 ²⁾	RL1	0.09 kW 4-pole 1400	0.18
1.9	6000 ²⁾	RXL1	0.09 kW 4-pole 1400	0.12
ATL 28				
93	1250 ¹⁾	RH2	0.25 kW 2-pole 2800	0.38
60	1850 ¹⁾	RV2	0.25 kW 2-pole 2800	0.38
46	1950 ¹⁾	RH1	0.25 kW 2-pole 2800	0.27
30	3300 ¹⁾	RN2	0.25 kW 2-pole 2800	0.33
23	2500 ¹⁾	RH1	0.18 kW 4-pole 1400	0.27
15	5600 ¹⁾	RL2	0.25 kW 2-pole 2800	0.25
7.5	8000 ²⁾	RL1	0.25 kW 2-pole 2800	0.18
3.5	8000 ²⁾	RL1	0.18 kW 4-pole 1400	0.18
1.9	8000 ²⁾	RXL1	0.18 kW 4-pole 1400	0.12
ATL 30				
93	1650 ¹⁾	RV2	0.25 kW 2-pole 2800	0.37
46	2550 ¹⁾	RV1	0.25 kW 2-pole 2800	0.25
23	5200 ¹⁾	RN2	0.25 kW 2-pole 2800	0.28
15	6850 ¹⁾	RL2	0.25 kW 2-pole 2800	0.22
11	8500 ¹⁾	RXL2	0.25 kW 2-pole 2800	0.18
7.5	10000 ¹⁾²⁾	RL1	0.25 kW 2-pole 2800	0.16
5.5	10000 ²⁾	RXL1	0.25 kW 2-pole 2800	0.13
4	10000 ²⁾	RL1	0.18 kW 4-pole 1400	0.16
2.7	10000 ²⁾	RXL1	0.18 kW 4-pole 1400	0.13
ATL 40				
93	3500 ¹⁾	RV2	0.55 kW 2-pole 2800	0.37
46	5400 ¹⁾	RV1	0.55 kW 2-pole 2800	0.26
23	10500 ¹⁾	RN2	0.55 kW 2-pole 2800	0.25
18	12000 ²⁾	RL2	0.55 kW 2-pole 2800	0.24
11	12000 ²⁾	RN1	0.55 kW 2-pole 2800	0.18
8.5	12000 ²⁾	RXL2	0.55 kW 2-pole 2800	0.12
5.5	12000 ²⁾	RN1	0.37 kW 4-pole 1400	0.18
4.5	12000 ²⁾	RL1	0.37 kW 4-pole 1400	0.17
2.1	12000 ²⁾	RXL1	0.37 kW 4-pole 1400	0.08

Linear actuators ATL Series

ACME SCREW LINEAR ACTUATORS ATL Series with AC 1-PHASE MOTOR
 PERFORMANCE with: Duty Cycle $F_d = 30\%$ over 10 min at ambient temperature 25 °C

LINEAR SPEED [mm/s]	DYNAMIC LOAD [N]	RATIO	MOTOR: POWER [kW] – N° of POLES SPEED [rpm]	SELF-LOCKING COEFFICIENT
ATL 20				
93	600 ¹⁾	RH2	0.12 kW 2-pole 2800	0.40
60	1000 ¹⁾	RV2	0.12 kW 2-pole 2800	0.41
46	850 ¹⁾	RH2	0.09 kW 4-pole 1400	0.40
35	1100 ¹⁾	RH1	0.12 kW 2-pole 2800	0.25
30	1750 ¹⁾	RN2	0.12 kW 2-pole 2800	0.35
22	1500 ¹⁾	RV1	0.12 kW 2-pole 2800	0.25
15	3000 ¹⁾	RL2	0.12 kW 2-pole 2800	0.27
11	3750 ¹⁾	RN1	0.12 kW 2-pole 2800	0.22
7.5	4000 ¹⁾²⁾	RL2	0.09 kW 4-pole 1400	0.27
5.5	4000 ²⁾	RL1	0.12 kW 2-pole 2800	0.16
2.8	4000 ²⁾	RL1	0.09 kW 4-pole 1400	0.16
1.4	4000 ²⁾	RXL1	0.09 kW 4-pole 1400	0.11
ATL 25				
93	770 ¹⁾	RH2	0.12 kW 2-pole 2800	0.38
60	1100 ¹⁾	RV2	0.12 kW 2-pole 2800	0.38
46	1200 ¹⁾	RH1	0.12 kW 2-pole 2800	0.27
28	2050 ¹⁾	RN2	0.12 kW 2-pole 2800	0.33
23	1600 ¹⁾	RH1	0.09 kW 4-pole 1400	0.27
14	3450 ¹⁾	RL2	0.12 kW 2-pole 2800	0.25
7	5100 ¹⁾	RL1	0.12 kW 2-pole 2800	0.18
3.5	6000 ²⁾	RL1	0.09 kW 4-pole 1400	0.18
1.9	6000 ²⁾	RXL1	0.09 kW 4-pole 1400	0.12
ATL 28				
93	1250 ¹⁾	RH2	0.25 kW 2-pole 2800	0.38
60	1850 ¹⁾	RV2	0.25 kW 2-pole 2800	0.38
46	1950 ¹⁾	RH1	0.25 kW 2-pole 2800	0.27
30	3300 ¹⁾	RN2	0.25 kW 2-pole 2800	0.33
23	2500 ¹⁾	RH1	0.18 kW 4-pole 1400	0.27
15	5600 ¹⁾	RL2	0.25 kW 2-pole 2800	0.25
7.5	8000 ²⁾	RL1	0.25 kW 2-pole 2800	0.18
3.5	8000 ²⁾	RL1	0.18 kW 4-pole 1400	0.18
1.9	8000 ²⁾	RXL1	0.18 kW 4-pole 1400	0.12
ATL 30				
93	1500 ¹⁾	RV2	0.25 kW 2-pole 2800	0.37
46	2350 ¹⁾	RV1	0.25 kW 2-pole 2800	0.25
23	4800 ¹⁾	RN2	0.25 kW 2-pole 2800	0.28
15	6300 ¹⁾	RL2	0.25 kW 2-pole 2800	0.22
11	8000 ¹⁾	RXL2	0.25 kW 2-pole 2800	0.18
7.5	9200 ¹⁾	RL1	0.25 kW 2-pole 2800	0.16
5.5	10000 ²⁾	RXL1	0.25 kW 2-pole 2800	0.13
4	10000 ²⁾	RL1	0.18 kW 4-pole 1400	0.16
2.7	10000 ²⁾	RXL1	0.18 kW 4-pole 1400	0.13
ATL 40				
93	3400 ¹⁾	RV2	0.55 kW 2-pole 2800	0.37
46	5400 ¹⁾	RV1	0.55 kW 2-pole 2800	0.26
23	10000 ¹⁾	RN2	0.55 kW 2-pole 2800	0.25
18	12000 ²⁾	RL2	0.55 kW 2-pole 2800	0.24
11	12000 ²⁾	RN1	0.55 kW 2-pole 2800	0.18
8.5	12000 ²⁾	RXL2	0.55 kW 2-pole 2800	0.12
5.5	12000 ²⁾	RN1	0.37 kW 4-pole 1400	0.18
4.5	12000 ²⁾	RL1	0.37 kW 4-pole 1400	0.17
2.1	12000 ²⁾	RXL1	0.37 kW 4-pole 1400	0.08

Linear actuators ATL Series

ACME SCREW LINEAR ACTUATORS ATL Series with DC MOTOR

PERFORMANCE with: Duty Cycle $F_i = 30\%$ over 10 min at ambient temperature 25 °C

LINEAR SPEED [mm/s]	DYNAMIC LOAD [N]	RATIO	CURRENT [A]	SELF-LOCKING COEFFICIENT
ATL 20 with DC motor 24 V 3000 rpm 100 W 5.5 A				
100	600 ¹⁾	RH2	10	0.40
64	920 ¹⁾	RV2	9.5	0.41
37	1150 ¹⁾	RH1	9	0.25
32	1650 ¹⁾	RN2	9	0.35
24	1700 ¹⁾	RV1	8.5	0.25
16	2800 ¹⁾	RL2	8.5	0.27
12	2900 ¹⁾	RN1	8	0.22
8	4000 ²⁾	RXL2	6.5	0.18
6	4000 ²⁾	RL1	6	0.16
3	4000 ²⁾	RXL1	3	0.11
ATL 25 with DC motor 24 V 3000 rpm 150 W 8.4 A				
100	900 ¹⁾	RH2	14.5	0.38
64	1330 ¹⁾	RV2	13.5	0.38
50	1450 ¹⁾	RH1	15	0.27
32	2100 ¹⁾	RV1	14	0.27
16	4000 ¹⁾	RL2	12	0.25
8	6000 ²⁾	RL1	11.5	0.18
4	6000 ²⁾	RXL1	5.5	0.12
ATL 30 with DC motor 24 V 3000 rpm 300 W 15.6 A				
100	1750 ¹⁾	RV2	26	0.37
50	2750 ¹⁾	RV1	27	0.25
25	5600 ¹⁾	RN2	23	0.28
16	7500 ¹⁾	RL2	21	0.22
12	8400 ¹⁾	RN1	22	0.20
8	10000 ²⁾	RL1	18	0.16
6	10000 ²⁾	RXL1	15	0.13
ATL 40 with DC motor 24 V 3000 rpm 500 W 25 A				
100	3000 ¹⁾	RV2	43	0.37
50	4700 ¹⁾	RV1	44	0.26
25	9200 ¹⁾	RN2	38	0.25
20	11000 ¹⁾	RL2	36	0.24
12	12000 ²⁾	RN1	31	0.18
10	12000 ²⁾	RL1	26	0.17
4.5	12000 ²⁾	RXL1	17	0.08

1) value limited by electric motor power

The total dynamic efficiency (η) of ATL Series actuators, used to determine the DYNAMIC LOAD is calculated as follows:

$$\eta = \eta_1 \times \eta_2 \times \eta_3$$

where:

η_1 – wormgear dynamic efficiency, calculated according to BS 721 : Part 2 : 1983

η_2 – acme screw-bronze nut dynamic efficiency, calculated with reference to the speed

$\eta_3 = 0.9$ – bearings and sealing elements "efficiency"

2) limit value of linear actuator dynamic load capacity (see page 42)

Linear actuators ATL Series

ACME SCREW LINEAR ACTUATORS ATL Series, size 20 – 25 – 28 – 30 – 40
AC 3-phase or 1-phase MOTOR – with Electric Stroke Limit Device FCE

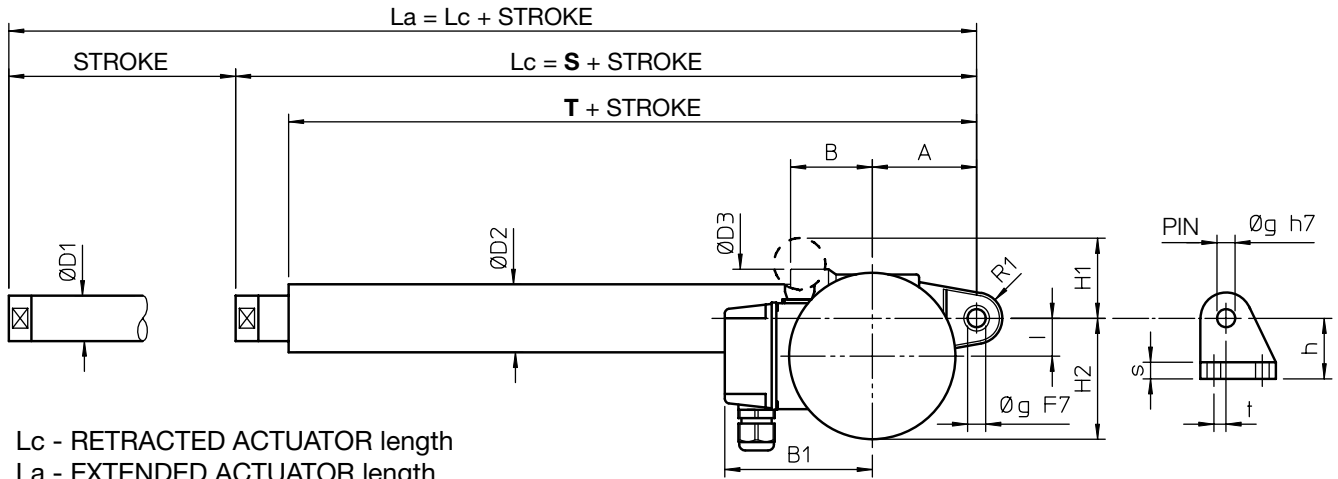

Lc - RETRACTED ACTUATOR length
La - EXTENDED ACTUATOR length

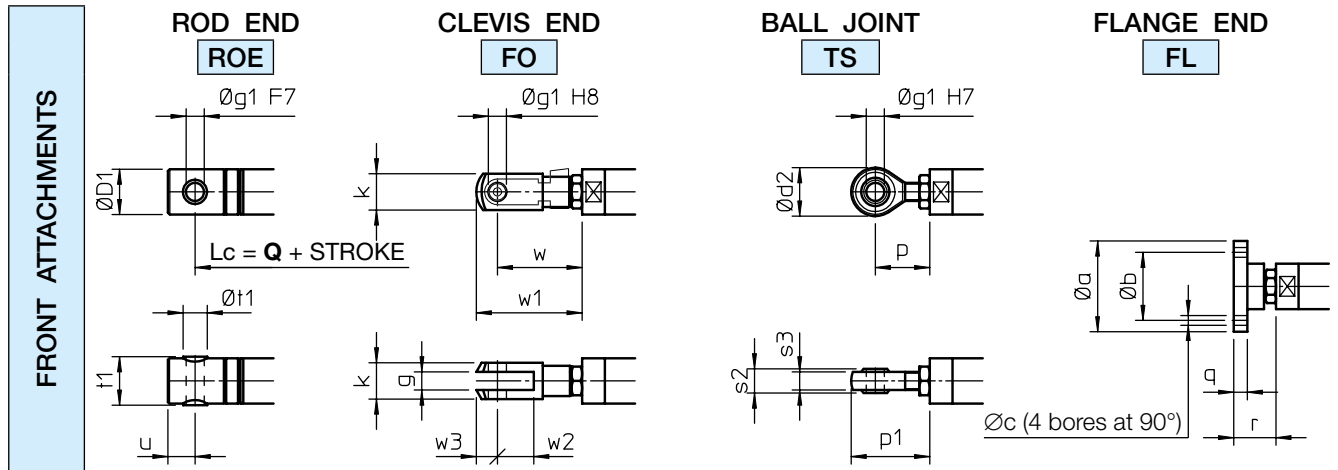
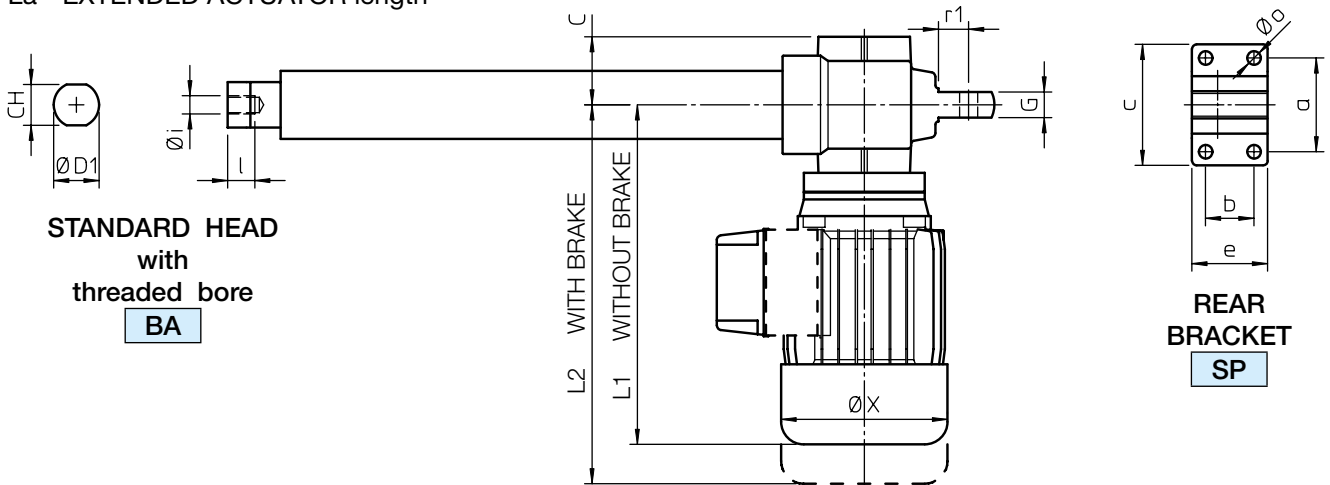

ELECTRIC STROKE LIMIT DEVICE FCE

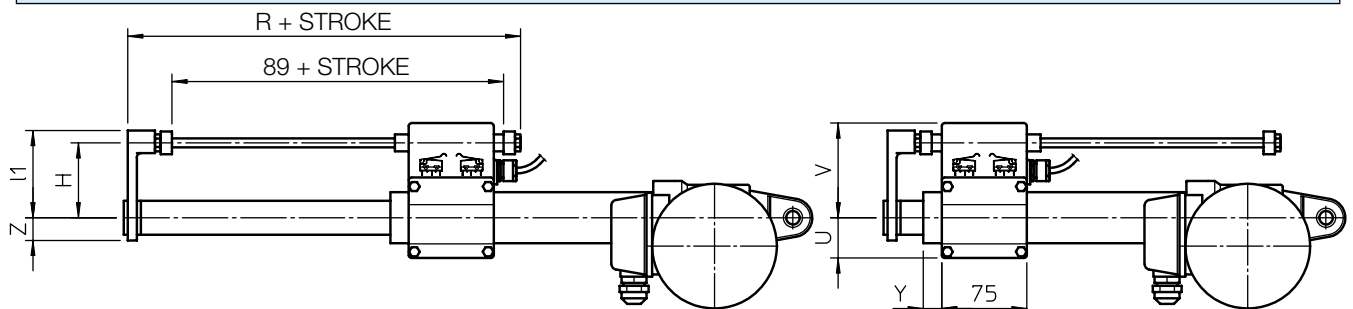

Linear actuators ATL Series

ACME SCREW LINEAR ACTUATORS ATL Series, size 20 – 25 – 28 – 30 – 40
AC 3-phase or 1-phase MOTOR – with Electric Stroke Limit Device FCE

STANDARD STROKE LENGTHS

	STROKE CODE	C100	C200	C300	C400	C500	C600	C700	C800	S	T	Q
ATL 20	STROKE [mm]	100	200	300	400	500	600	700	800	183	152	198
ATL 25										190	155	207
ATL 28										190	155	207
ATL 30										218	180	238
ATL 40										275	225	300

NOTE: Different stroke lengths available on request. $L_a = L_c + \text{STROKE}$

For stroke lengths longer than 800 mm it is necessary to increase the guided length between push rod and outer tube to avoid axial backlash. Dimensions **S**, **T** and **Q** shall be considered increased by 200 mm for stroke lengths up to 1500 mm.

For stroke lengths longer than 1500 mm, please, contact SERVOMECH.

	A	B	B1	C	CH	∅ D1	∅ D2	∅ D3	G	H1	H2	I	L1	L2
ATL 20	69	54	110	45	22	25	36	65	17	50	80	25	225	251
ATL 25	69	54	110	45	27	30	45	65	17	50	80	25	225	251
ATL 28	69	54	115	45	27	30	45	65	17	60	87	25	251	287
ATL 30	76	62	115	50	30	35	55	78	20	60	92	30	255	291
ATL 40	104	78	124	57	36	40	60	92	24	50	115	40	284	373

	R1	∅ X	a	b	c	e	∅ g	h	∅ i	l	∅ o	r1	s	t
ATL 20	17	110	62	32	80	50	12	40	M10×1.5	17	9	20	11	8
ATL 25	17	110	62	32	80	50	12	40	M12×1.75	18	9	20	11	8
ATL 28	17	123	62	32	80	50	12	40	M12×1.75	18	9	20	11	8
ATL 30	18	123	72	38	90	58	14	45	M14×2	24	9	20	12	8
ATL 40	28	150	85	55	110	81	20	58	M20×1.5	27	11	32	15	15

FRONT ATTACHMENT Dimensions

	∅ a	∅ b	∅ c	∅ D1	∅ d2	g	∅ g1	k	p	p1
ATL 20	55	40	5.5	25	28	10	10	20	31	45
ATL 25	60	45	6.5	30	32	12	12	24	36	52
ATL 28	60	45	6.5	30	32	12	12	24	36	52
ATL 30	65	50	6.5	35	36	14	14	27	36	54
ATL 40	80	60	8.5	40	50	20	20	40	53	78

	q	r	s2	s3	t1	∅ t1	u	w	w1	w2	w3
ATL 20	8	27	14	11	26	14	15	49	61	20	12
ATL 25	9	28	16	12	32	16	18	56	70	24	14
ATL 28	9	28	16	12	32	16	18	56	70	24	14
ATL 30	9	32	19	14	36	18	21	65	81	28	16
ATL 40	10	42	25	18	42	25	27	90	115	40	25

ELECTRIC STROKE LIMIT DEVICE FCE Dimensions

	H	R	U	V	Y	Z	l1
ATL 20	62	144	30	80	20	18	72
ATL 25	67	146	35	85	16	20	77
ATL 28	67	146	35	85	16	20	77
ATL 30	71	147	38	90	15	23	82
ATL 40	75	163	43	93	17	25	85

Linear actuators ATL Series

ACME SCREW LINEAR ACTUATORS ATL Series, size 20 – 25 – 28 – 30 – 40
 AC 3-phase or 1-phase MOTOR – with Magnetic Stroke Limit Switches FCM

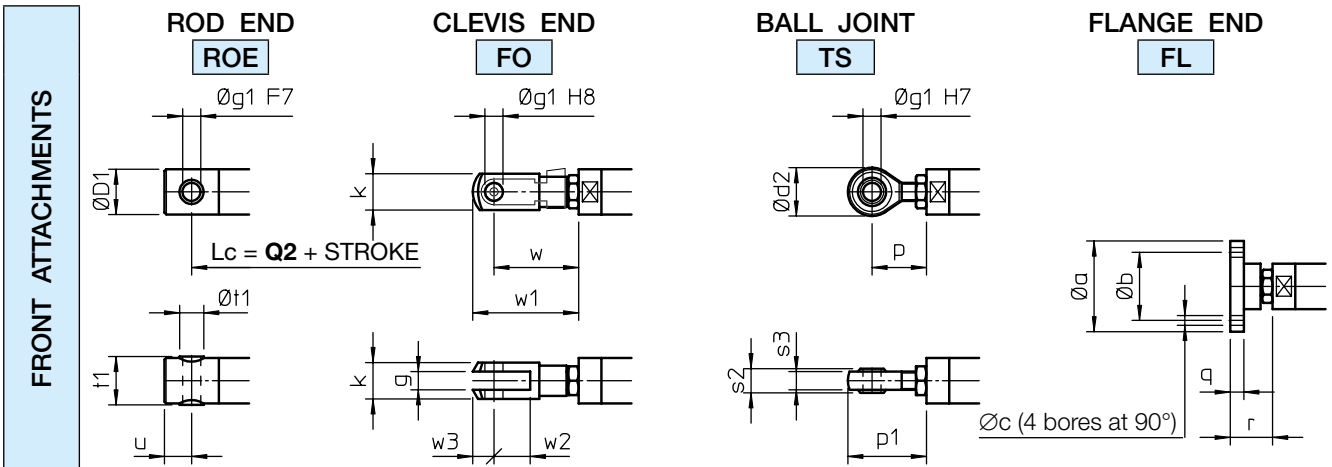
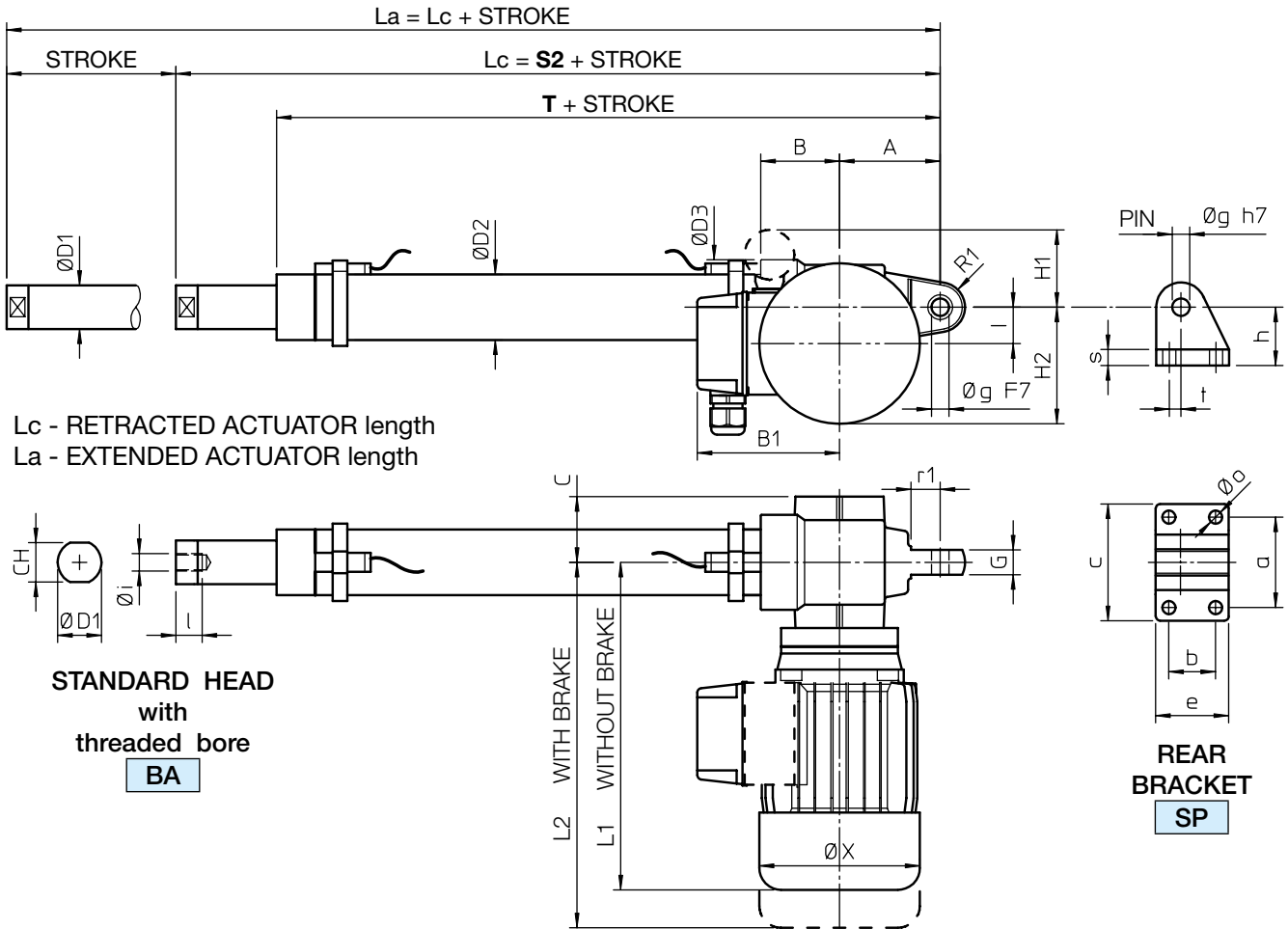

MAGNETIC STROKE LIMIT SWITCHES FCM Dimensions

	L	
	REED CONTACT NC or (NC+NO)	NO
ATL 20	18.5	23.5
ATL 25	26.5	31.5
ATL 28	26.5	31.5
ATL 30	29	34
ATL 40	35	40

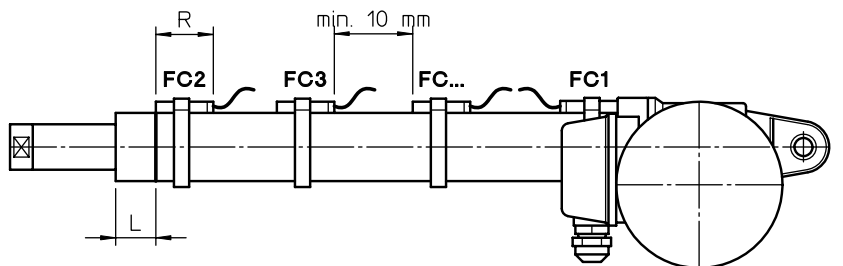

Linear actuators ATL Series

ACME SCREW LINEAR ACTUATORS ATL Series, size 20 – 25 – 28 – 30 – 40
AC 3-phase or 1-phase MOTOR – with Magnetic Stroke Limit Switches FCM

STANDARD STROKE LENGTHS

	STROKE CODE	C100	C200	C300	C400	C500	C600	C700	C800	S2	T	Q2
ATL 20	STROKE [mm]	72	172	272	372	472	572	672	772	235	180	235
ATL 25		66	166	266	366	466	566	666	766	252	189	255
ATL 28		66	166	266	366	466	566	666	766	252	189	255
ATL 30		68	168	268	368	468	568	668	768	276	212	282
ATL 40		63	163	263	363	463	563	663	763	339	262	351

NOTE: Different stroke lengths available on request. $L_a = L_c + \text{STROKE}$

For stroke lengths longer than 800 mm it is necessary to increase the guided length between push rod and outer tube to avoid axial backlash. Dimensions **S2**, **T** and **Q2** shall be considered increased by 200 mm for stroke lengths up to 1500 mm.

For stroke lengths longer than 1500 mm, please, contact SERVOMECH.

	A	B	B1	C	CH	∅ D1	∅ D2	∅ D3	G	H1	H2	I	L1	L2
ATL 20	69	54	110	45	22	25	36	65	17	50	80	25	225	251
ATL 25	69	54	110	45	27	30	45	65	17	50	80	25	225	251
ATL 28	69	54	115	45	27	30	45	65	17	60	87	25	251	287
ATL 30	76	62	115	50	30	35	55	78	20	60	92	30	255	291
ATL 40	104	78	124	57	36	40	60	92	24	50	115	40	284	373

	R1	∅ X	a	b	c	e	∅ g	h	∅ i	l	∅ o	r1	s	t
ATL 20	17	110	62	32	80	50	12	40	M10×1.5	17	9	20	11	8
ATL 25	17	110	62	32	80	50	12	40	M12×1.75	18	9	20	11	8
ATL 28	17	123	62	32	80	50	12	40	M12×1.75	18	9	20	11	8
ATL 30	18	123	72	38	90	58	14	45	M14×2	24	9	20	12	8
ATL 40	28	150	85	55	110	81	20	58	M20×1.5	27	11	32	15	15

FRONT ATTACHMENT Dimensions

	∅ a	∅ b	∅ c	∅ D1	∅ d2	g	∅ g1	k	p	p1
ATL 20	55	40	5.5	25	28	10	10	20	31	45
ATL 25	60	45	6.5	30	32	12	12	24	36	52
ATL 28	60	45	6.5	30	32	12	12	24	36	52
ATL 30	65	50	6.5	35	36	14	14	27	36	54
ATL 40	80	60	8.5	40	50	20	20	40	53	78

	q	r	s2	s3	t1	∅ t1	u	w	w1	w2	w3
ATL 20	8	27	14	11	26	14	15	49	61	20	12
ATL 25	9	28	16	12	32	16	18	56	70	24	14
ATL 28	9	28	16	12	32	16	18	56	70	24	14
ATL 30	9	32	19	14	36	18	21	65	81	28	16
ATL 40	10	42	25	18	42	25	27	90	115	40	25

MAGNETIC STROKE LIMIT SWITCHES FCM Technical features and dimensions

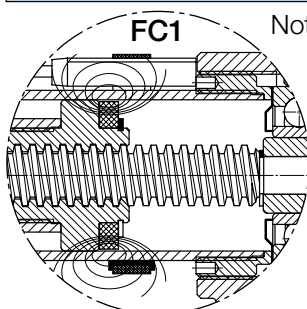

Note: - The travel length performed by an actuator with FCM is reduced if compared to the travel length of an actuator without FCM, because the REED SWITCH FC1 gives the stopping signal to the motor before the actuator reaches its minimum retracted length.

Therefore the actuator in retracted position is longer.

- Additional extra magnetic REED SWITCHES are available for intermediate positions.
- The minimum distance between the REED SWITCHES must be of at least 10 mm.
- REED SWITCH Normally Closed (NC) R = 39 mm
- REED SWITCH Change-over (NC+NO) R = 39 mm
- REED SWITCH Normally Open (NO) R = 29 mm

Linear actuators ATL Series

ACME SCREW LINEAR ACTUATORS ATL Series, size 20 – 25 – 30 – 40
 DC MOTOR – without stroke limit switches or with Electric Stroke Limit Device FCE

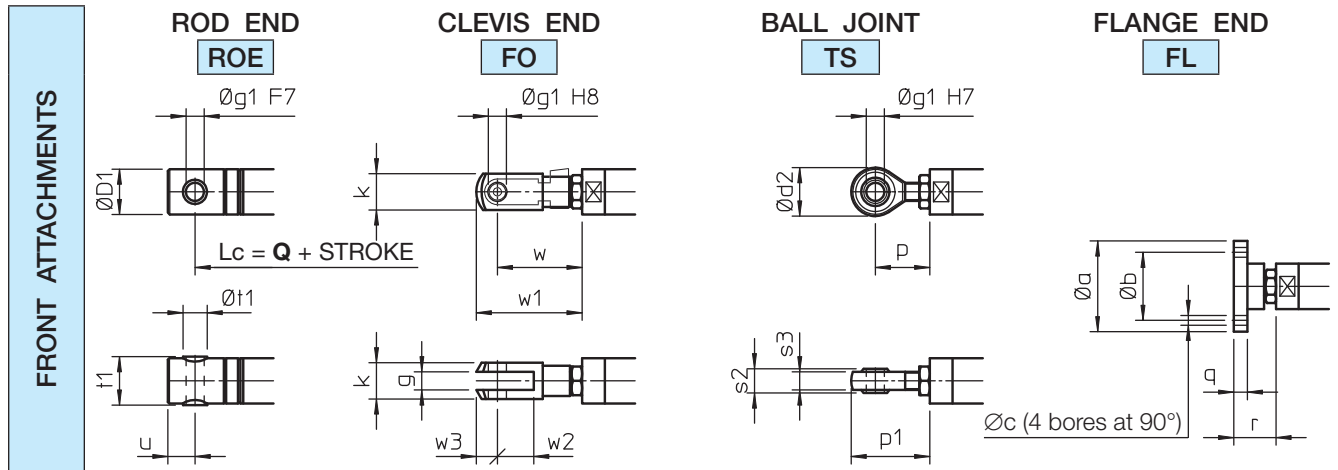
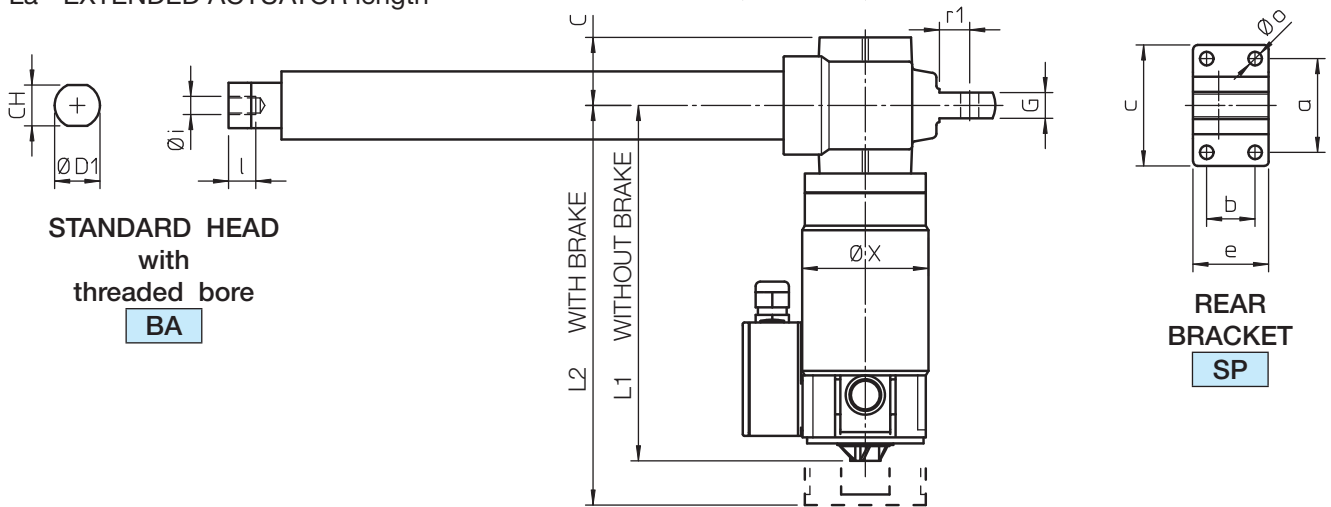
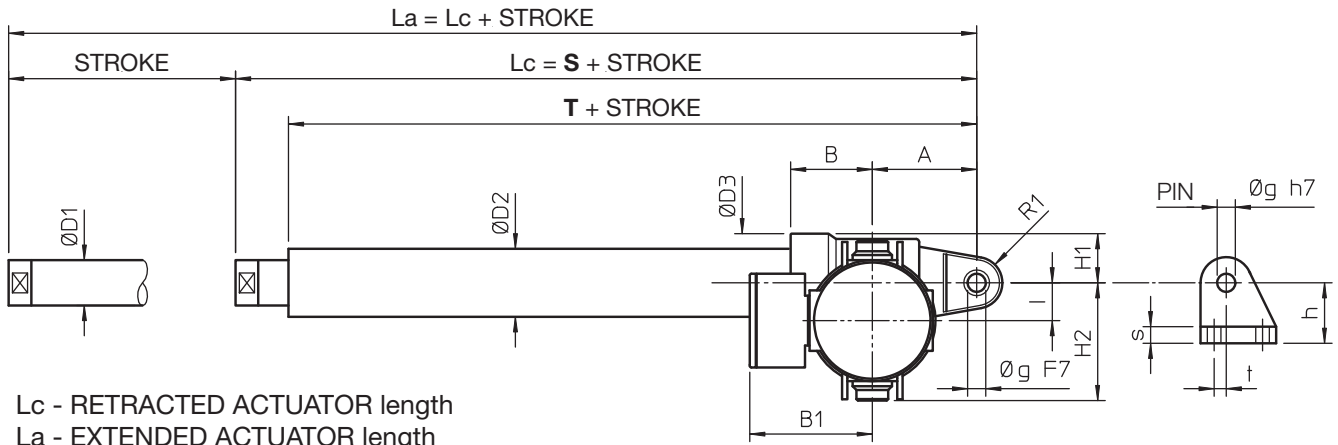

ELECTRIC STROKE LIMIT DEVICE FCE

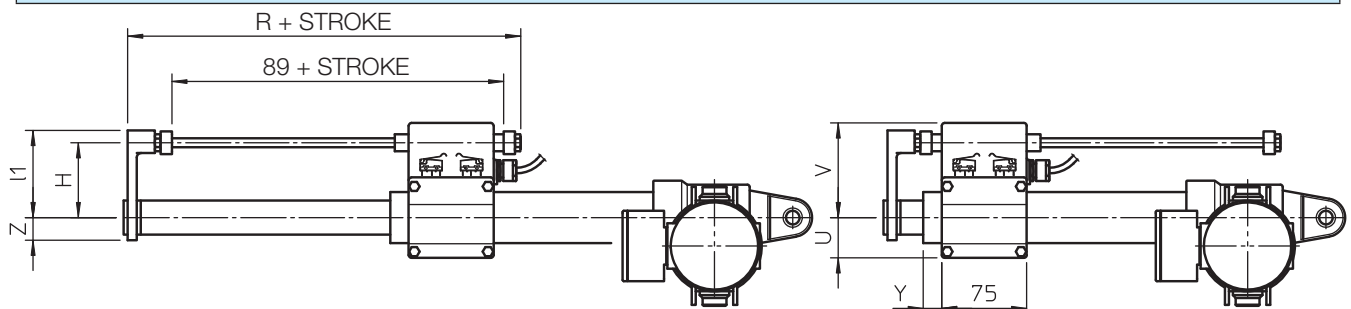

Linear actuators ATL Series

ACME SCREW LINEAR ACTUATORS ATL Series, size 20 – 25 – 30 – 40
DC MOTOR – without stroke limit switches or with Electric Stroke Limit Device FCE

STANDARD STROKE LENGTHS

	STROKE CODE	C100	C200	C300	C400	C500	C600	C700	C800	S	T	Q
ATL 20	STROKE [mm]	100	200	300	400	500	600	700	800	183	152	198
ATL 25										190	155	207
ATL 30										218	180	238
ATL 40										275	225	300

NOTE: Different stroke lengths available on request. $L_a = L_c + \text{STROKE}$

For stroke lengths longer than 800 mm it is necessary to increase the guided length between push rod and outer tube to avoid axial backlash. Dimensions **S**, **T** and **Q** shall be considered increased by 200 mm for stroke lengths up to 1500 mm.

For stroke lengths longer than 1500 mm, please, contact SERVOMECH.

	A	B	B1	C	CH	∅ D1	∅ D2	∅ D3	G	H1	H2	I	L1	L2
ATL 20	69	54	80	45	22	25	36	65	17	33	80	25	202	243
ATL 25	69	54	80	45	27	30	45	65	17	33	80	25	235	276
ATL 30	76	62	80	50	30	35	55	78	20	39	92	30	291	332
ATL 40	104	78	80	57	36	40	60	92	24	46	115	40	391	432

	R1	∅ X	a	b	c	e	∅ g	h	∅ i	l	∅ o	r1	s	t
ATL 20	17	107	62	32	80	50	12	40	M10×1.5	17	9	20	11	8
ATL 25	17	107	62	32	80	50	12	40	M12×1.75	18	9	20	11	8
ATL 30	18	107	72	38	90	58	14	45	M14×2	24	9	20	12	8
ATL 40	28	107	85	55	110	81	20	58	M20×1.5	27	11	32	15	15

FRONT ATTACHMENT Dimensions

	∅ a	∅ b	∅ c	∅ D1	∅ d2	g	∅ g1	k	p	p1
ATL 20	55	40	5.5	25	28	10	10	20	31	45
ATL 25	60	45	6.5	30	32	12	12	24	36	52
ATL 30	65	50	6.5	35	36	14	14	27	36	54
ATL 40	80	60	8.5	40	50	20	20	40	53	78

	q	r	s2	s3	t1	∅ t1	u	w	w1	w2	w3
ATL 20	8	27	14	11	26	14	15	49	61	20	12
ATL 25	9	28	16	12	32	16	18	56	70	24	14
ATL 30	9	32	19	14	36	18	21	65	81	28	16
ATL 40	10	42	25	18	42	25	27	90	115	40	25

ELECTRIC STROKE LIMIT DEVICE FCE Dimensions

	H	R	U	V	Y	Z	l1
ATL 20	62	144	30	80	20	18	72
ATL 25	67	146	35	85	16	20	77
ATL 30	71	147	38	90	15	23	82
ATL 40	75	163	43	93	17	25	85

Linear actuators ATL Series

ACME SCREW LINEAR ACTUATORS ATL Series, size 20 – 25 – 30 – 40
DC MOTOR – with Magnetic Stroke Limit Switches FCM

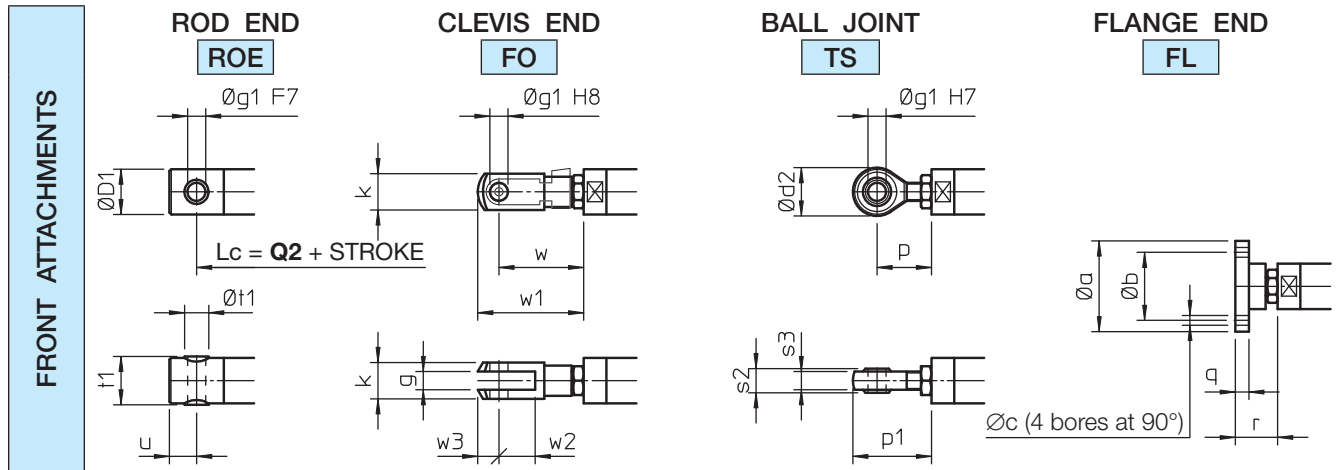
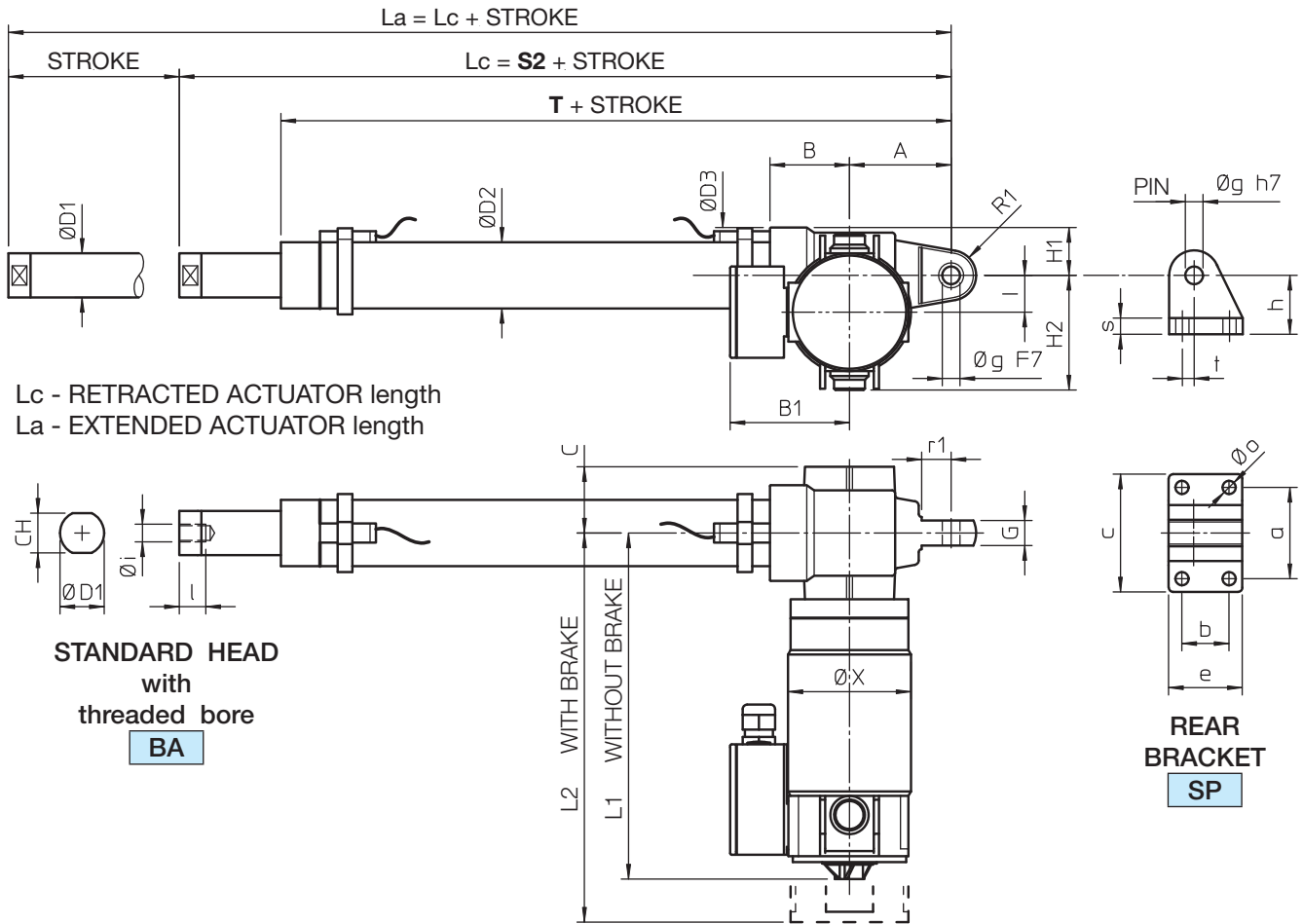

MAGNETIC STROKE LIMIT SWITCHES FCM Dimensions

	L	
	REED CONTACT NC or (NC+NO)	NO
ATL 20	18.5	23.5
ATL 25	26.5	31.5
ATL 28	26.5	31.5
ATL 30	29	34
ATL 40	35	40

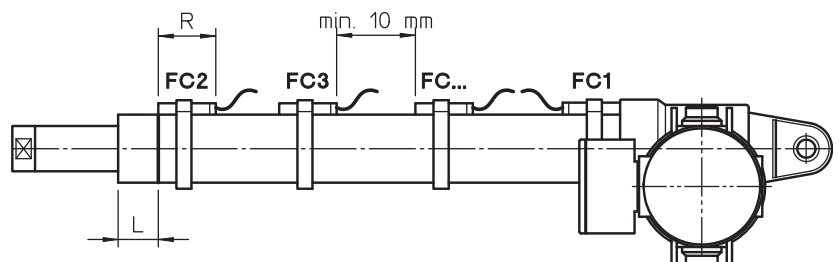

Linear actuators ATL Series

**ACME SCREW LINEAR ACTUATORS ATL Series, size 20 – 25 – 30 – 40
DC MOTOR – with Magnetic Stroke Limit Switches FCM**

STANDARD STROKE LENGTHS

	STROKE CODE	C100	C200	C300	C400	C500	C600	C700	C800	S2	T	Q2
ATL 20	STROKE [mm]	72	172	272	372	472	572	672	772	235	180	235
ATL 25		66	166	266	366	466	566	666	766	252	189	255
ATL 30		68	168	268	368	468	568	668	768	276	212	282
ATL 40		63	163	263	363	463	563	663	763	339	262	351

NOTE: Different stroke lengths available on request. $L_a = L_c + \text{STROKE}$

For stroke lengths longer than 800 mm it is necessary to increase the guided length between push rod and outer tube to avoid axial backlash. Dimensions **S2**, **T** and **Q2** shall be considered increased by 200 mm for stroke lengths up to 1500 mm.

For stroke lengths longer than 1500 mm, please, contact SERVOMECH.

	A	B	B1	C	CH	∅ D1	∅ D2	∅ D3	G	H1	H2	I	L1	L2
ATL 20	69	54	80	45	22	25	36	65	17	33	80	25	202	243
ATL 25	69	54	80	45	27	30	45	65	17	33	80	25	235	276
ATL 30	76	62	80	50	30	35	55	78	20	39	92	30	291	332
ATL 40	104	78	80	57	36	40	60	92	24	46	115	40	391	432

	R1	∅ X	a	b	c	e	∅ g	h	∅ i	l	∅ o	r1	s	t
ATL 20	17	107	62	32	80	50	12	40	M10×1.5	17	9	20	11	8
ATL 25	17	107	62	32	80	50	12	40	M12×1.75	18	9	20	11	8
ATL 30	18	107	72	38	90	58	14	45	M14×2	24	9	20	12	8
ATL 40	28	107	85	55	110	81	20	58	M20×1.5	27	11	32	15	15

FRONT ATTACHMENT Dimensions

	∅ a	∅ b	∅ c	∅ D1	∅ d2	g	∅ g1	k	p	p1
ATL 20	55	40	5.5	25	28	10	10	20	31	45
ATL 25	60	45	6.5	30	32	12	12	24	36	52
ATL 30	65	50	6.5	35	36	14	14	27	36	54
ATL 40	80	60	8.5	40	50	20	20	40	53	78

	q	r	s2	s3	t1	∅ t1	u	w	w1	w2	w3
ATL 20	8	27	14	11	26	14	15	49	61	20	12
ATL 25	9	28	16	12	32	16	18	56	70	24	14
ATL 30	9	32	19	14	36	18	21	65	81	28	16
ATL 40	10	42	25	18	42	25	27	90	115	40	25

MAGNETIC STROKE LIMIT SWITCHES FCM Technical features and dimensions

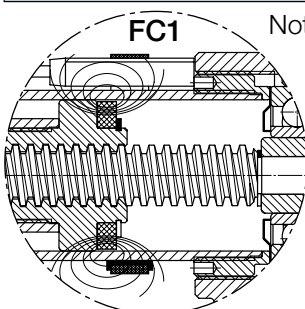

Note: - The travel length performed by an actuator with FCM is reduced if compared to the travel length of an actuator without FCM, because the REED SWITCH FC1 gives the stopping signal to the motor before the actuator reaches its minimum retracted length.

Therefore the actuator in retracted position is longer.

- Additional extra magnetic REED SWITCHES are available for intermediate positions.
- The minimum distance between the REED SWITCHES must be of at least 10 mm.
- REED SWITCH Normally Closed (NC) R = 39 mm
- REED SWITCH Change-over (NC+NO) R = 39 mm
- REED SWITCH Normally Open (NO) R = 29 mm