

16B 160B5

Variator size 16B Variatore tipo 16B

Input/Entrata	160B5	132B5 on request
Output/Uscita	132B5	-

Oil quantity/Olio: 7 lt. for B3 horizontal position (contact Var-Spe for vertical position)

Weight/Peso	Kg	lbs
Without motor/Senza motore	150	331
With motor/Con motore 9.2 kW	242	533
With motor/Con motore 11 kW	278	613

Torque-speed diagram
Diagramma coppia-velocità

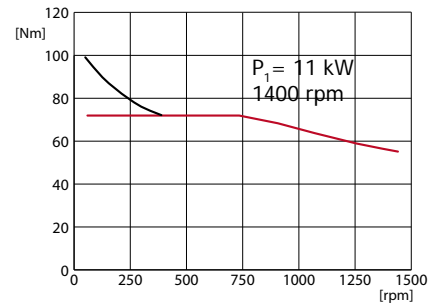
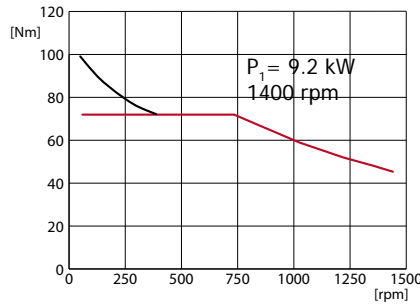

— Torque available for continuous duty
Coppia nominale per funzionamento continuo

— Starting torque for very intermittent use, as motor is loaded with 200% Amperes. Warning: not to burn the motor.
Coppia di spunto per uso intermittente, il motore assorbe il 200% degli Amperes. Attenzione a non bruciare il motore

Moto-variator Moto-variatore

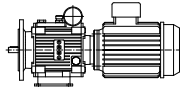

Speed range	P ₁	n ₁	M ₂	M _{st}	n _{2min}	P ₂	Atex Category	Input Flange	Output flange	Weight Peso	Dimens.
[rpm]	[kW]	[rpm]	[Nm]	[Nm]	[rpm]	[kW]		160B5	132B5	kg/lbs	Pag.
0-1430	9.2	1400	44.8	98.1	50	6.7	2/3		✓	242/533	43
0-1430	11	1400	55.3		50	8.3		✓	✓	278/613	
0-900	7.5	900	60.1	50	5.6	✓		✓	273/602		

P₁ = motor power/potenza motore; n₁ = motor speed/velocità motore;

M₂ = variator output torque at max speed/coppia uscita variatore alla max velocità

M_{st} = variator output starting torque/coppia spunto uscita variatore; n_{2min} = minimum speed with stable torque/velocità minima con coppia stabile;

P₂ = variator output power/potenza uscita variatore.

16B 160B5

DIMENSIONI / DIMENSIONS

9.2-11 kW

Variator size 16B: dimensions with 11 kW electric motor/ Variatore tipo 16B: dimensioni con motore elettrico 11 kW

Type 21.16/000

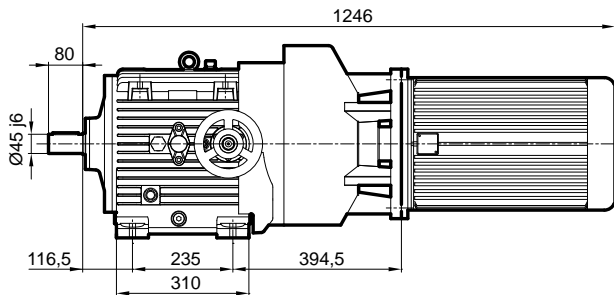

Type 21.16B/000/1

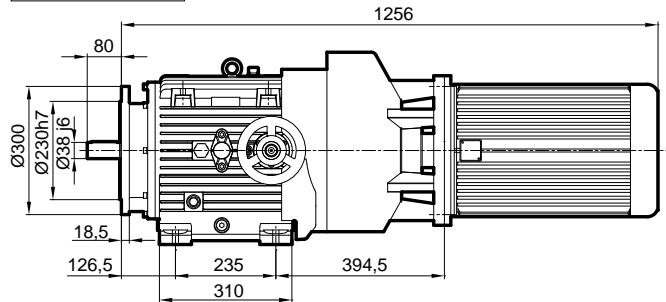

Type 22.16B/000

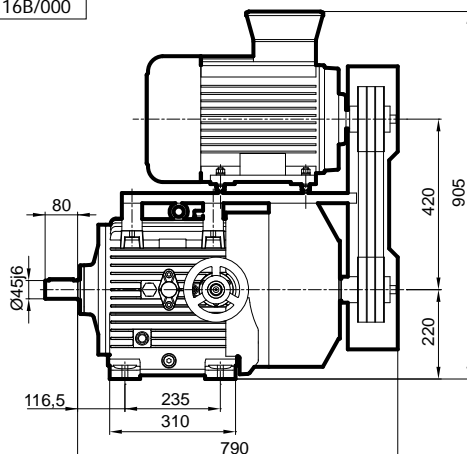

Type 22.16B/000/1

With output flange
Con flangia uscita

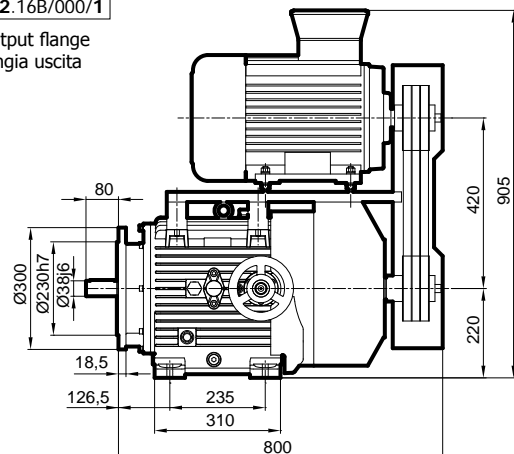

Variator: **16B**
 Input: **160 B5 (132B5 on request)**

Oil q.ty/Q.tà olio: 7.0 lt. for horizontal position
 (for vertical position contact Var-Spe)

Weight	150 kg
Peso	331 lbs

Type 11.16B/...

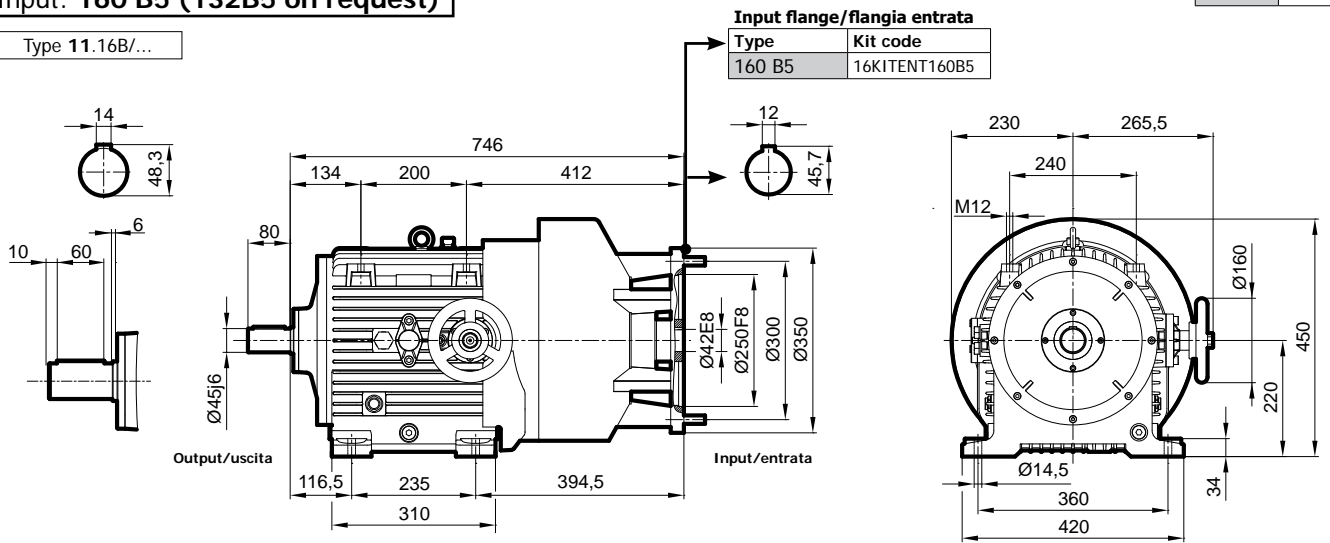

With **output flange**
 Con flangia uscita

Type 11.16B/.../1

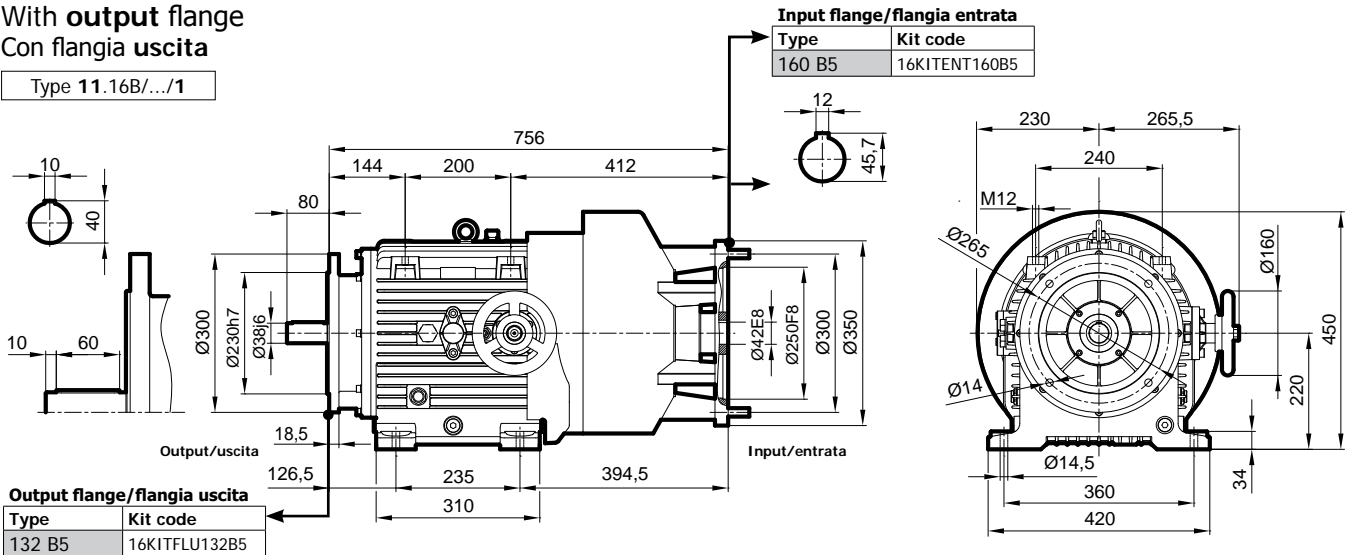

Solid input shaft
 Albero maschio ingresso

Type 10.16B/...

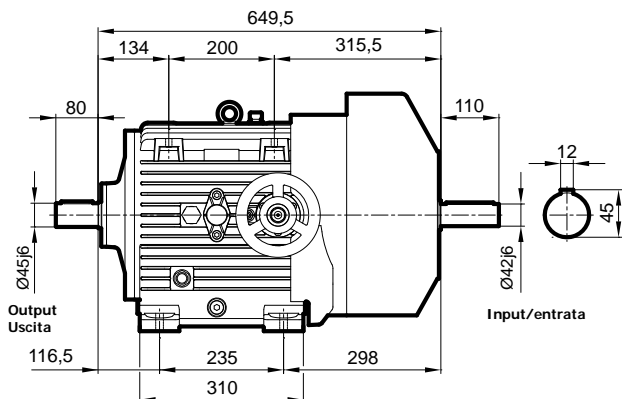

Type 10.16B/.../1

With **Output Flange**
 Con Flangia Uscita

