

17 11-15 kW

SELEZIONE / SELECTION

17 160B5

Variator size 17 Variatore tipo 17

Input/Entrata	160 B5
Output/Uscita	160 B5

Oil quantity/olio: 12 lt. for horizontal and vertical positions
(14 lt. for 30° inclined positions)

Weight/Peso	Kg	lbs
Without motor/Senza motore	220	485
With motor/Con motore 11 kW	345	761
With motor/Con motore 15 kW	365	805

Torque-speed diagram
Diagramma coppia-velocità

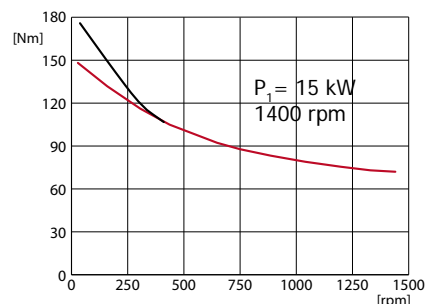
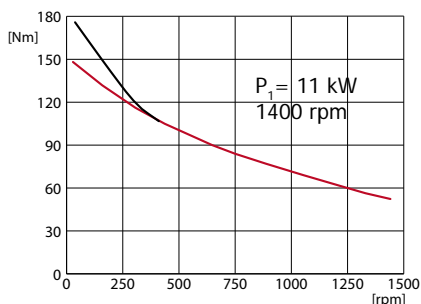

— Torque available for continuous duty
Coppia nominale per funzionamento continuo

— Starting torque for very intermittent use, as motor is loaded with 200% Amperes. Warning: not to burn the motor.
Coppia di spunto per uso intermittente, il motore assorbe il 200% degli Amperes. Attenzione a non bruciare il motore

Moto-variator Moto-variatore

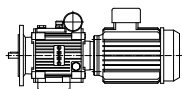

Speed range	P ₁	n ₁	M ₂	M _{st}	n _{2min}	P ₂	Atex Category	Input Flange	Output flange	Weight Peso	Dimens.
[rpm]	[kW]	[rpm]	[Nm]	[Nm]	[rpm]	[kW]		160B5	160B5	kg/lbs	Pag.
0-1430	11	1400	52.3	176.6	50	7.8	2/3	✓	✓	345/761	45
0-1430	15	1400	71.7		50	10.7		✓	✓	365/805	
0-900	11	900	85.5		50	8.0		✓	✓	365/805	

P₁ = motor power/potenza motore; n₁ = motor speed/velocità motore;

M₂ = variator output torque at max speed/coppia uscita variatore alla max velocità

M_{st} = variator output starting torque/coppia spunto uscita variatore; n_{2min} = minimum speed with stable torque/velocità minima con coppia stabile;

P₂ = variator output power/potenza uscita variatore.

17 160B5

DIMENSIONI / DIMENSIONS

11-15 kW

Variator size 17: dimensions with 15 kW electric motor/ Variatore tipo 17: dimensioni con motore elettrico 15 kW

Type 21.17/000

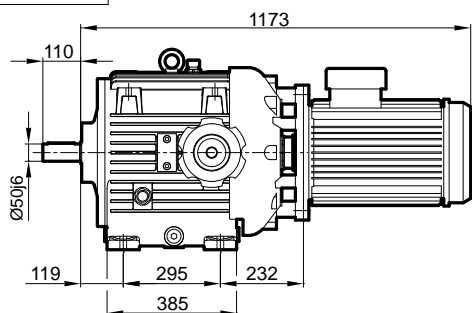

Type 21.17/000/1

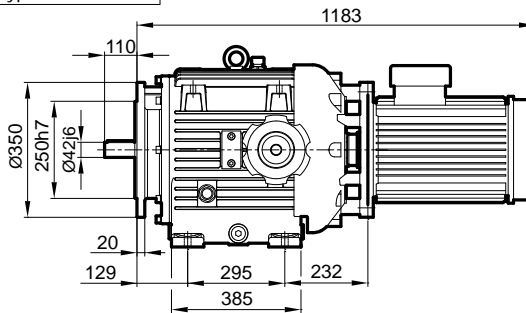

Type 22.17/000

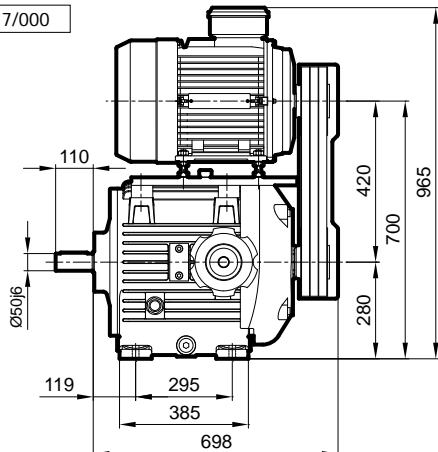

Type 22.17/000/1

With output flange
Con flangia uscita

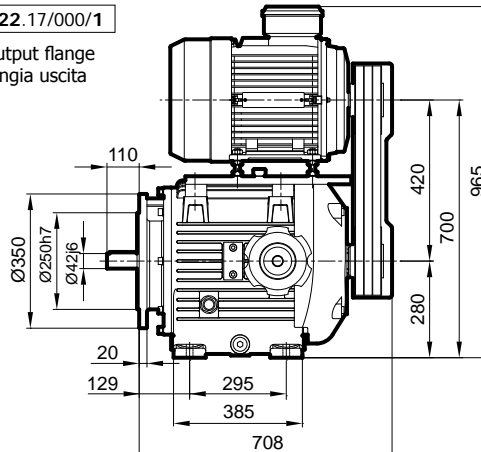

Variator: **17**
Input: **160 B5**

Oil q.ty/Q.tà olio: 12 lt. for horizontal and vertical position
(14 lt. for 30° inclined position)

Weight	220 kg
Peso	485 lbs

Type 11.17/...

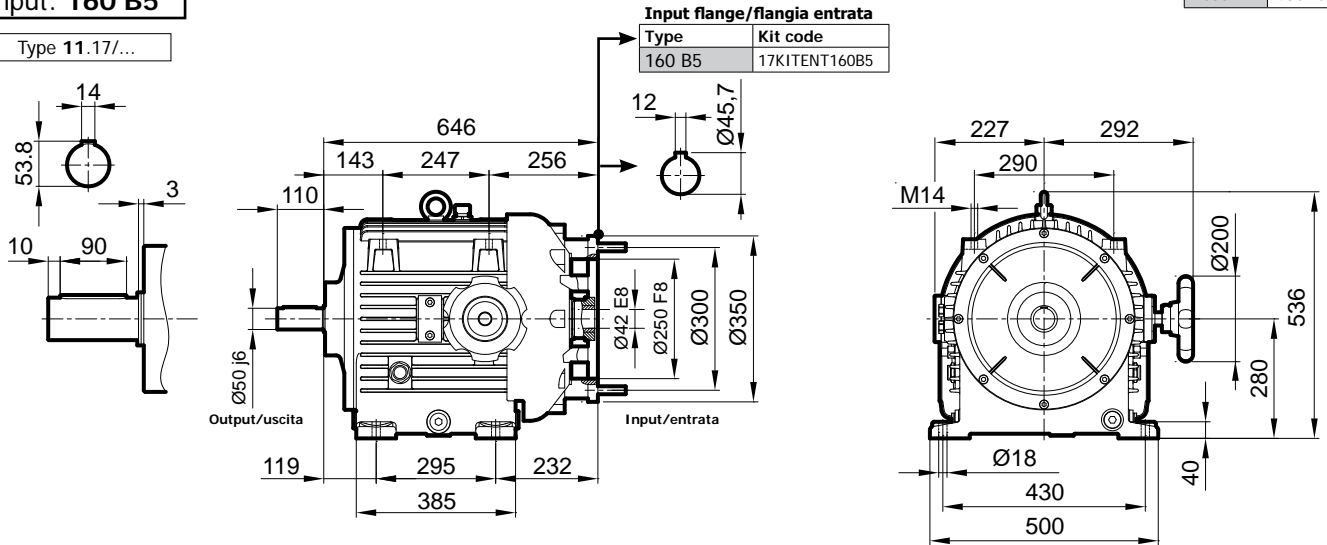

With output flange
Con flangia uscita

Type 11.17/.../1

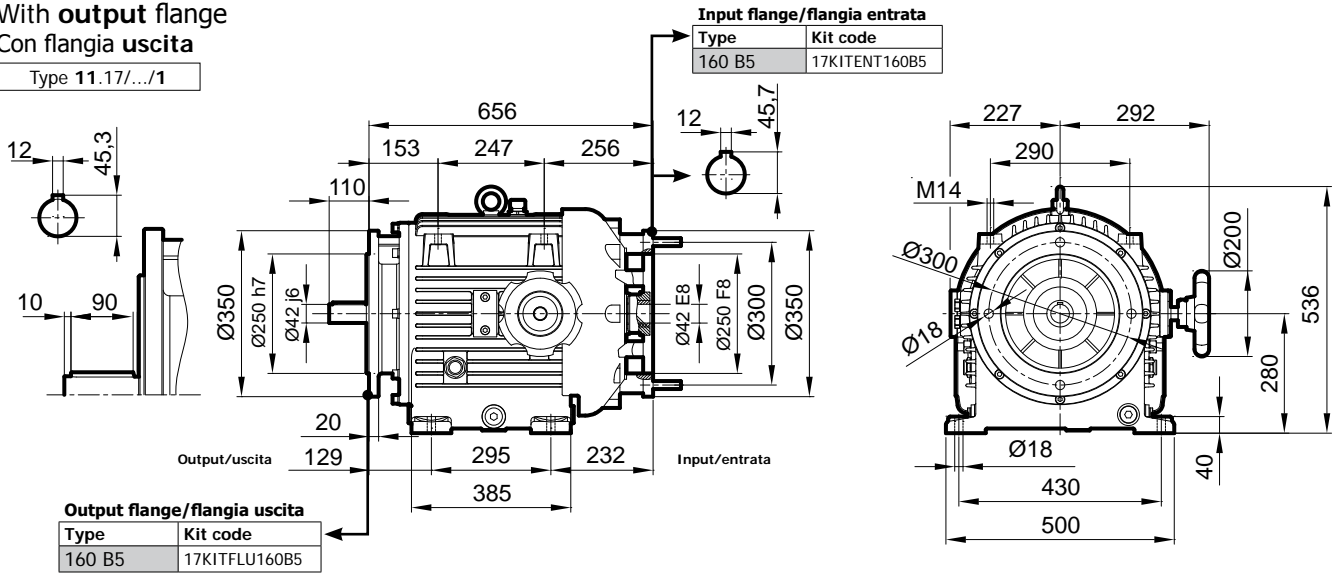

Solid input shaft
Albero maschio ingresso

Type 10.17/...

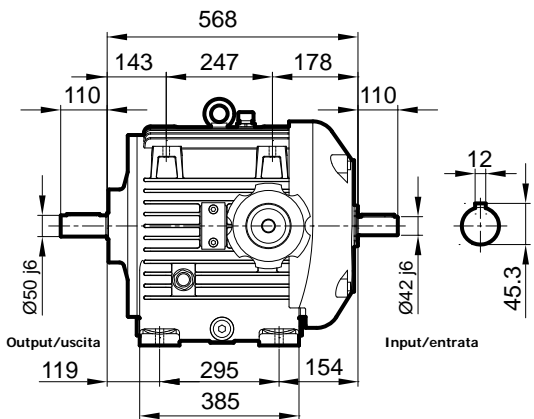

Type 10.17/.../1

With Output Flange
Con Flangia Uscita

