

K5 100-112B5

Variator size K5

Variatore tipo K5

| | | | | |
|---------------|------------|--------|-------|-------|
| Input/Entrata | 100-112 B5 | - | - | - |
| Output/Uscita | 100-112 B5 | 100B14 | 90 B5 | 90B14 |

Oil quantity/Quantità olio: 2 lt. for B3 posit.
(2,5 lt. for V5 and 2,4 lt. for the other posit.)

| Weight/Peso | Kg | lbs |
|------------------------------|------|------|
| Without motor/Senza motore | 27.0 | 59.5 |
| With motor/Con motore 2.2 kW | 48.0 | 106 |
| With motor/Con motore 3 kW | 51.7 | 114 |
| With motor/Con motore 4 kW | 57.5 | 127 |

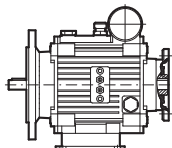

For dimensions, see pag.28/Per le dimensioni, vedi pag.28

Torque-speed diagram
Diagramma coppia-velocità

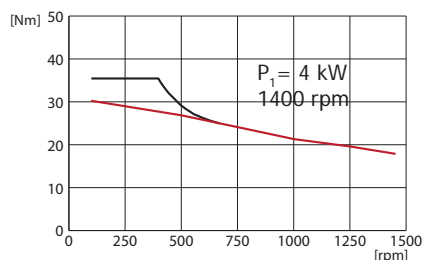
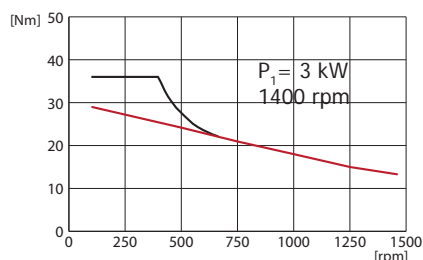
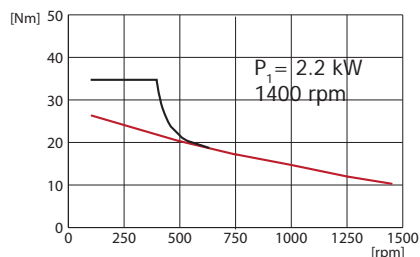

— Torque available for continuous duty
Coppia nominale per funzionamento continuo

— Starting torque for very intermittent use, as motor is loaded with 200% Ampere. Warning: not to burn the motor.
Coppia di spunto per uso intermittente, il motore assorbe il 200% degli Ampere. Attenzione a non bruciare il motore

Moto-variator Moto-variatore

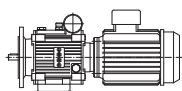

| Speed range | P ₁ | n ₁ | M ₂ | M _{st} | n _{2min} | P ₂ | Atex Category | Input Flange Flangia ingr. | Output flange Flangia uscita | | | Weight Peso | Dimens. | |
|-------------|----------------|----------------|----------------|-----------------|-------------------|----------------|---------------|-------------------------------|---------------------------------|------|-------|----------------|----------|------|
| [rpm] | [kW] | [rpm] | [Nm] | [Nm] | [rpm] | [kW] | | 100-112B5 | 100-112B5 | 90B5 | 90B14 | 100B14 | kg/lbs | Pag. |
| 0-1430 | 2.2 | 1400 | 10.3 | 35 | 50 | 1.6 | 2/3 | √ | √ | √ | √ | √ | 48.0/106 | 28 |
| 0-1430 | 3 | 1400 | 13.8 | 35 | 50 | 2.2 | | √ | √ | √ | √ | √ | 51.7/114 | |
| 0-1430 | 4 | 1400 | 17.9 | 35 | 50 | 2.9 | | √ | √ | √ | √ | √ | 57.5/127 | |
| 0-900 | 1.5 | 900 | 10.9 | 35 | 50 | 1.1 | | √ | √ | √ | √ | √ | 46.1/102 | |
| 0-900 | 2.2 | 900 | 15.8 | 35 | 50 | 1.6 | | √ | √ | √ | √ | √ | 52.4/115 | |

P₁ = motor power/potenza motore; n₁ = motor speed/velocità motore;

M₂ = variator output torque at max speed/coppia uscita variatore alla max velocità

M_{st} = variator output starting torque/coppia spunto uscita variatore; n_{2min} = minimum speed with stable torque/velocità minima con coppia stabile;

P₂ = variator output power/potenza uscita variatore.

K5 100-112B5

DIMENSIONI / DIMENSIONS

2.2-3-4kW

Variator: **K5**
Input: **100 B5 - 112 B5**

Oil q.ty/Q.tà olio: 2 lt. for B3 posit.
(2,5 lt. for V5 and 2,4 lt. for the other posit.)

| Input flange/flangia entrata | |
|------------------------------|----------|
| Type | Kit code |
| 100-112 B5 | K5KITENT |

| | |
|--------|--------|
| Weight | 27 kg |
| Peso | 59 lbs |

With feet
Con piedi

Type 11.K5/.../A10

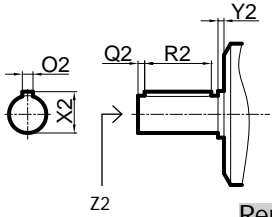

Removable
Rimovibile

Feet Kit options

| | |
|-----|------------|
| A10 | K5PIEDIA10 |
| A12 | K5PIEDIA12 |
| 14 | K5PIEDIA14 |

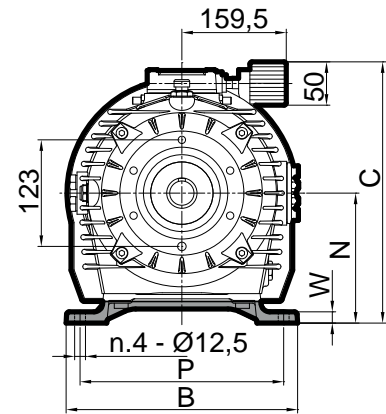
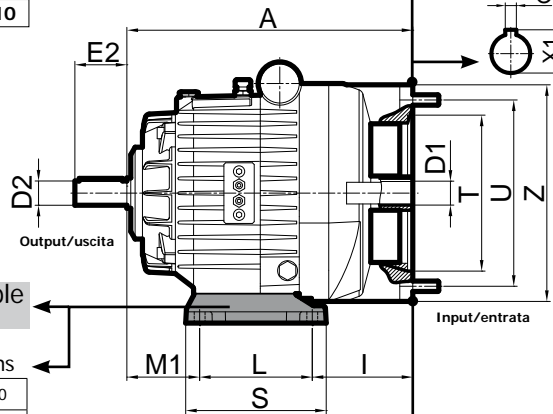

100-112B5 input flange

Ø shaft: output solid, input hollow/Ø albero: uscita cilindrico, entrata cavo

| Output/Uscita | D2 | E2 | O2 | X2 | Q2 | R2 | Y2 | Z2 |
|---------------|--------|----|----|------|----|----|-----|-------|
| Standard | Ø28 j6 | 60 | 8 | 31 | 5 | 50 | 4.5 | M8x20 |
| On request | Ø24 j6 | 50 | 8 | 27 | 5 | 40 | 4.5 | M8x20 |
| Input/Entrata | D1 | - | O1 | X1 | - | - | - | - |
| Standard | Ø28 F7 | | 8 | 31.2 | - | - | - | - |
| On request | Ø24 F7 | | 8 | 27.2 | - | - | - | - |

| A | Feet | A10-A12 | I | T | U | Z |
|-----|-------|---------|-------|-----|-----|-----|
| 330 | Piedi | 14 | 153.5 | 180 | 215 | 250 |
| | | | 116 | 180 | 215 | 250 |

| Feet | A10-A12 | B | C | L | M1 | N | P | S | W |
|-------|---------|-------|-------|-----|------|-----|-----|-------|------|
| Piedi | 14 | 272.2 | 281.5 | 100 | 76.5 | 130 | 240 | 133.7 | 12.5 |
| | | 267.2 | 301.5 | 130 | 84 | 150 | 235 | 162.2 | 12.5 |

With output flange and feet
Con flangia uscita e piedi

Type 11.K5/.../A10.1

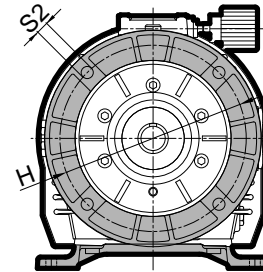
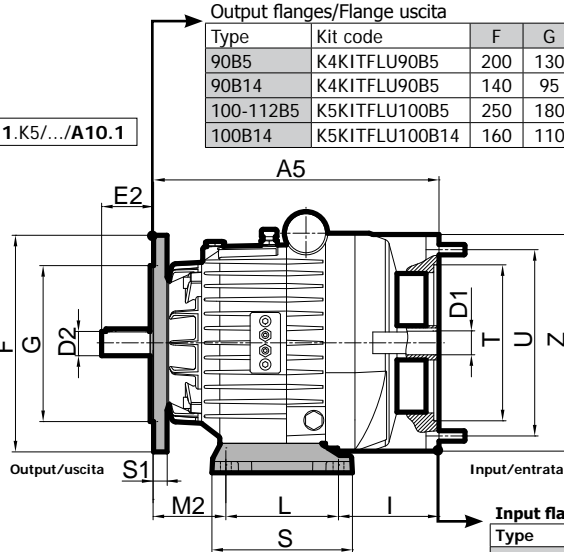
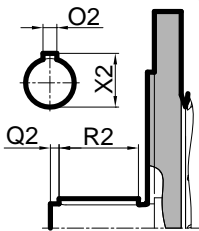

| | | | |
|-------|---------|------|-----|
| Feet | A10-A12 | M2 | A5 |
| Piedi | 14 | 76.5 | 330 |
| | | 84 | |

Output flanges/Flange uscita

| Type | Kit code | F | G | H | S1 | S2 |
|-----------|----------------|-----|-----|-----|------|-------|
| 90B5 | K4KITFLU90B5 | 200 | 130 | 165 | 13 | 11 |
| 90B14 | K4KITFLU90B5 | 140 | 95 | 115 | 18 | M8x10 |
| 100-112B5 | K5KITFLU100B5 | 250 | 180 | 215 | 15.5 | 14 |
| 100B14 | K5KITFLU100B14 | 160 | 110 | 130 | 14 | 9 |

| Input flange/flangia entrata | |
|------------------------------|----------|
| Type | Kit code |
| 100-112 B5 | K5KITENT |

Solid input shaft
Albero maschio ingresso

Type 10.K5/.../A10

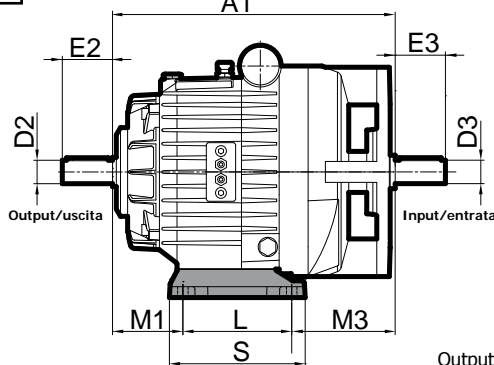
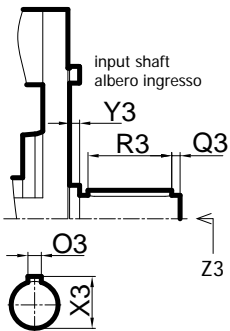

Ø solid input shaft / Ø albero ingresso maschio

| Input/Entrata | D3 | E3 | O3 | X3 | Q3 | R3 | Y3 | Z3 |
|---------------|--------|----|----|----|----|----|-----|-------|
| Standard | Ø28 j6 | 60 | 8 | 31 | 5 | 50 | 6 | M8x20 |
| On request | Ø24 j6 | 50 | 8 | 27 | 5 | 40 | 4.5 | M8x20 |

With Output Flange
Con Flangia Uscita

Type 10.K5/.../A10.1

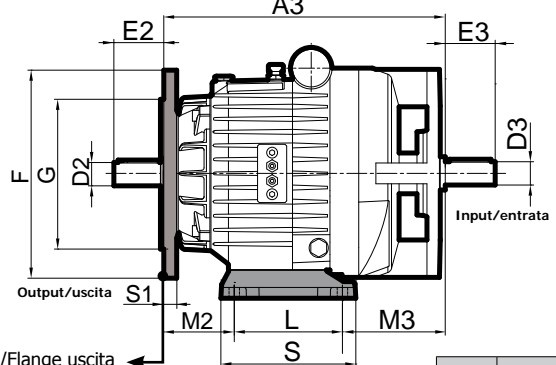

Output flanges/Flange uscita

| Type | Kit code |
|-----------|----------------|
| 90B5 | K4KITFLU90B5 |
| 90B14 | K4KITFLU90B5 |
| 100-112B5 | K5KITFLU100B5 |
| 100B14 | K5KITFLU100B14 |

| | | | | |
|-------|---------|-------|----|-----|
| A1 | A3 | | | |
| 337 | 337 | | | |
| M1 | M2 | M3 | | |
| 76.5 | 76.5 | 160.5 | | |
| Feet | A10-A12 | | | |
| Piedi | 14 | | | |
| | | 84 | 84 | 123 |

2.2-3-4kW

DIMENSIONI / DIMENSIONS

K5 100-112B5

Without feet
Senza piedi

Type 51.K5/.../...1

Input flange/flangia entrata

| Type | Kit code |
|------------|----------|
| 100-112 B5 | K5KITENT |

| | |
|--------|----------|
| Weight | 26.5 kg |
| Peso | 58.4 lbs |

With Output Flange
Con Flangia Uscita

Output flanges/Flange uscita

| Type | Kit code |
|-----------|----------------|
| 90B5 | K4KITFLU90B5 |
| 90B14 | K4KITFLU90B5 |
| 100-112B5 | K5KITFLU100B5 |
| 100B14 | K5KITFLU100B14 |

For dimensions see pag.28
Per dimensioni vedi pag.28

| B2 | B4 | C4 | I4 | I5 | L4 |
|-----|-----|-------|-------|-----|----|
| 265 | 184 | 276.5 | 152.5 | 117 | 88 |

| M4 | N4 | P4 | S4 | W4 | ØZ4 |
|-------|-----|-----|-----|----|--------|
| 89.5* | 125 | 140 | 136 | 9 | M10x20 |

*For 100B14 output flange/Per flangia uscita 100B14: M4=95.5

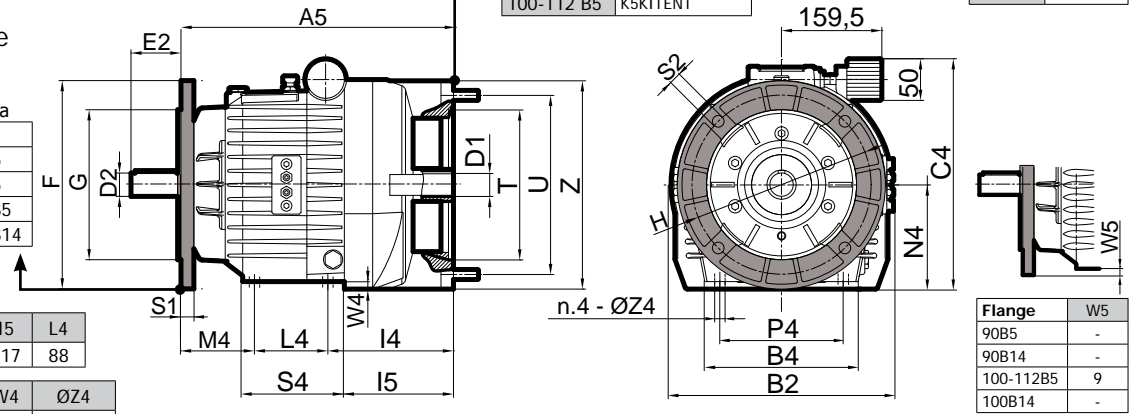

| Flange | W5 |
|-----------|----|
| 90B5 | - |
| 90B14 | - |
| 100-112B5 | 9 |
| 100B14 | - |

Without Output Flange,
without feet
Senza Flangia Uscita,
senza piedi

Type 51.K5/...

Input flange/flangia entrata

| Type | Kit code |
|------------|----------|
| 100-112 B5 | K5KITENT |

For the not indicated dimensions, see
the previous page
Per le quote non indicate, vedere la
pagina precedente

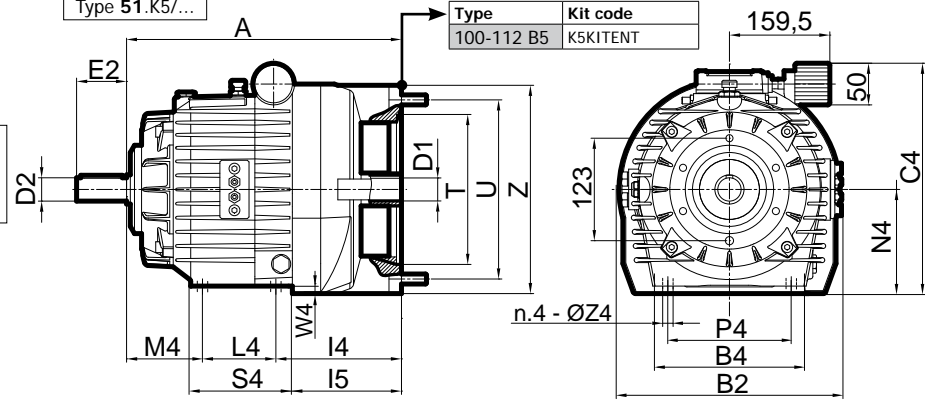

With 2.2-3-4 kW motor 4p
Con motore 2.2-3-4 kW 4p

Type 21.K5/.../A10

Removable
Rimovibile

Feet Kit options

| Feet | Kit options |
|------|-------------|
| A10 | K5PIEDIA10 |
| A12 | K5PIEDIA12 |
| 14 | K5PIEDIA14 |

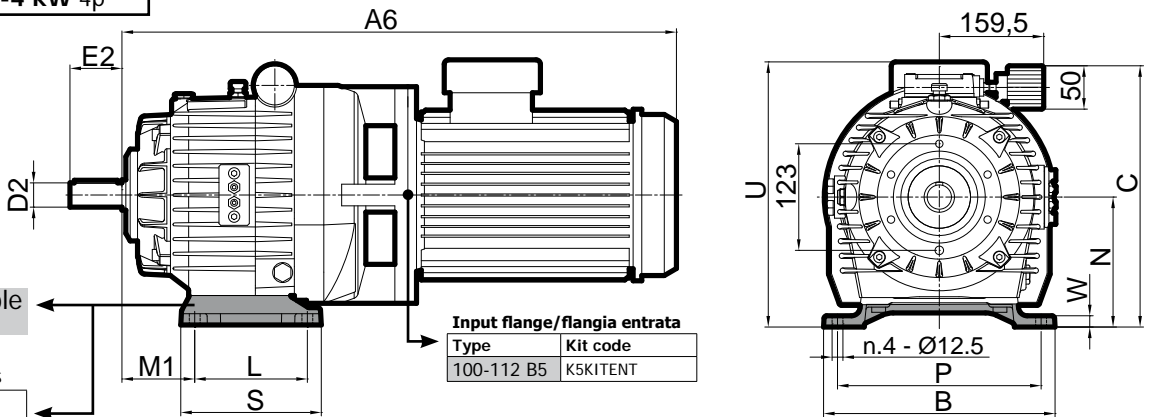

| | | |
|----------------|--------|-------------------|
| Weight Peso | 2.2 kW | 48.0 kg / 106 lbs |
| | 3 kW | 51.7 kg / 114 lbs |
| | 4 kW | 57.5 kg / 127 lbs |

With Output Flange
Con Flangia Uscita

Type 21.K5/.../A10.1

Output flanges/Flange uscita

| Type | Kit code |
|-----------|----------------|
| 90B5 | K4KITFLU90B5 |
| 90B14 | K4KITFLU90B5 |
| 100-112B5 | K5KITFLU100B5 |
| 100B14 | K5KITFLU100B14 |

For dimensions see pag.28
Per dimensioni vedi pag.28

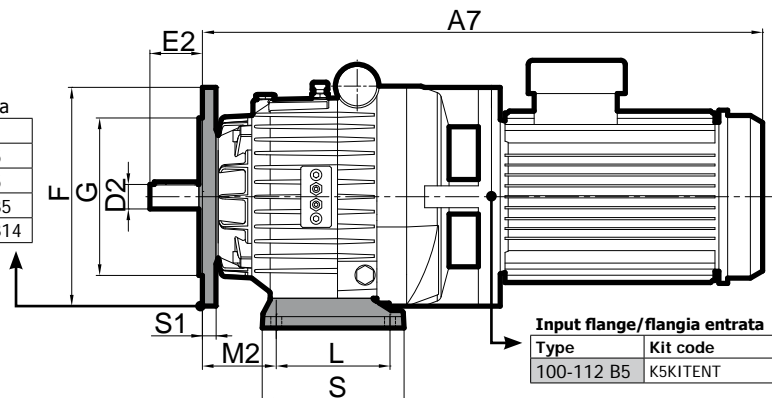

| Motor | A6 | A7 |
|--------|-----|-----|
| 2.2 kW | 656 | 656 |
| 3 kW | 656 | 656 |
| 4 kW | 665 | 665 |

| | | U | |
|---------------|---------|----------|------|
| | | 2.2-3 kW | 4 kW |
| Feet Piedi | A10-A12 | 277 | 300 |
| | 14 | 297 | 320 |