

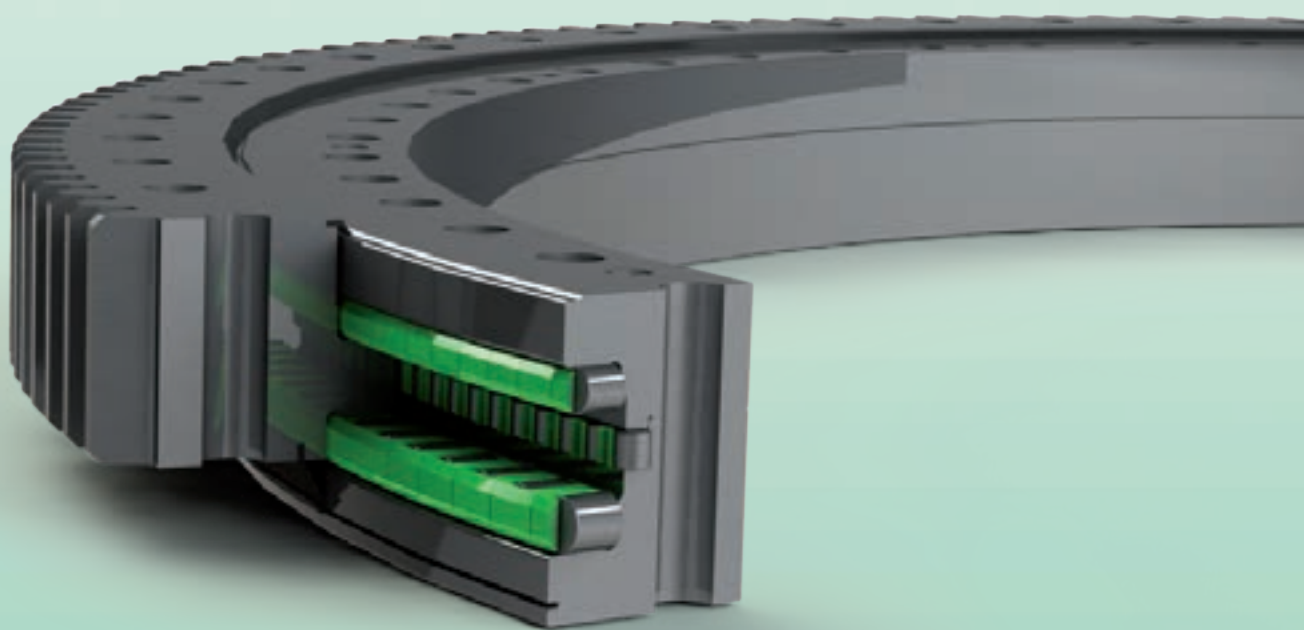

Cuscinetti di base a tre giri di rulli, dentatura esterna

Triple row roller bearing, external toothed



ER3 SERIES

ER3.20/25

SERIE STANDARD

STANDARD SERIES

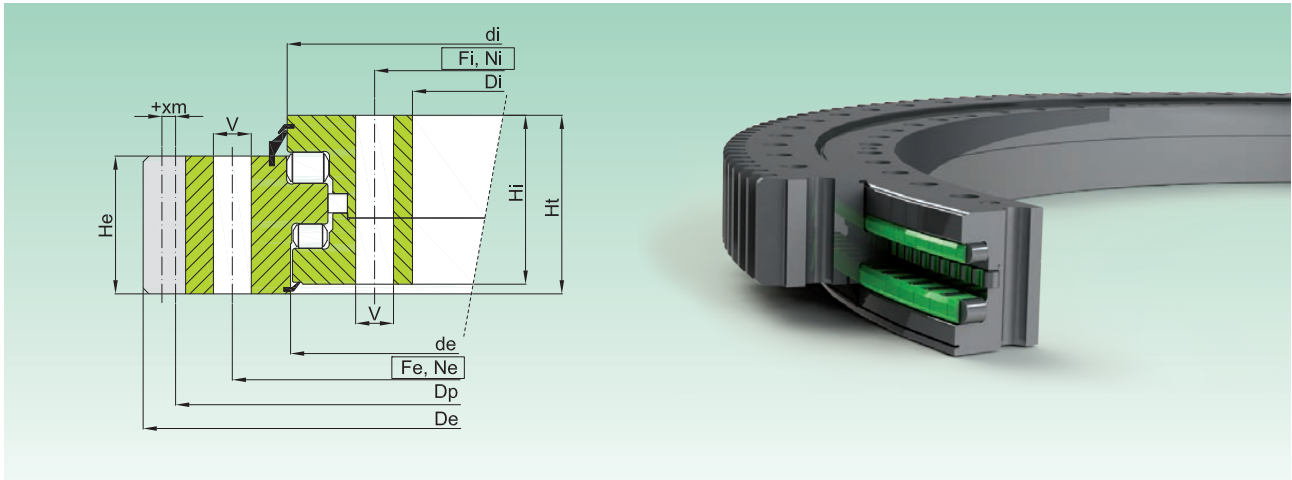

Codice Code	Curva Curve	Dimensioni Dimensions						Fori di fissaggio Fixing Holes				Dentatura Gear data					Peso Weight [kg]		
		De [mm]	de [mm]	di [mm]	Di [mm]	He [mm]	Hi [mm]	Ht [mm]	Fe [mm]	Fi [mm]	N [-]	V [mm]	m [mm]	Z [-]	xm [mm]	Dp [mm]		fz norm [kN]	fz max [kN]
ER3.20.1250.400-1SPPN	1	1461,6	1282	1280	1103	106	123	132	1355	1155	36	26	12	119	+0,50	1428	107	187	542
ER3.20.1400.400-1SPPN	2	1635,2	1432	1430	1253	106	123	132	1505	1305	36	26	14	114	+0,50	1596	136	236	646
ER3.20.1600.400-1SPPN	3	1831,2	1632	1630	1453	106	123	132	1705	1505	40	26	14	128	+0,50	1792	136	236	731
ER3.20.1800.400-1SPPN	4	2044,8	1832	1830	1653	106	123	132	1905	1705	46	26	16	125	+0,50	2000	163	285	844
ER3.20.2000.400-1SPPN	5	2236,8	2032	2030	1853	106	123	132	2105	1905	54	26	16	137	+0,50	2192	163	285	912
ER3.25.1800.400-1SPPN	6	2076,8	1826	1836	1619	117	138	147	1925	1685	36	33	16	127	+0,50	2032	172	306	1126
ER3.25.2000.400-1SPPN	7	2268,8	2026	2036	1819	117	138	147	2125	1885	44	33	16	139	+0,50	2224	172	306	1216
ER3.25.2240.400-1SPPN	8	2516,4	2266	2276	2059	117	138	147	2366	2125	48	33	18	137	+0,50	2466	202	358	1378
ER3.25.2500.400-1SPPN	9	2786,4	2526	2536	2319	117	138	147	2625	2385	54	33	18	152	+0,50	2736	202	358	1567
ER3.25.2800.400-1SPPN	10	3096	2826	2836	2619	117	138	147	2925	2685	60	33	20	152	+0,50	3040	232	407	1785

- Materiale: 42CrMo4 Q+T
 - Costruite con gioco positivo
 - Pieni di grasso, protetti da olio, e avvolti in resistente film plastico

- Material 42CrMo4 Q+T
 - Assembled with positive clearances
 - Full of grease, protected by oil and wrapped in resistant plastic film



Diagramma di carico statico valido per sforzi compressivi
 Static load charts valid for compressive loads



Carico sospeso: occorre verifica specifica della bulloneria
 Suspended load: specific bolts calculation required

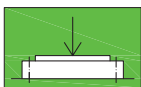
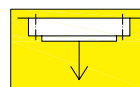
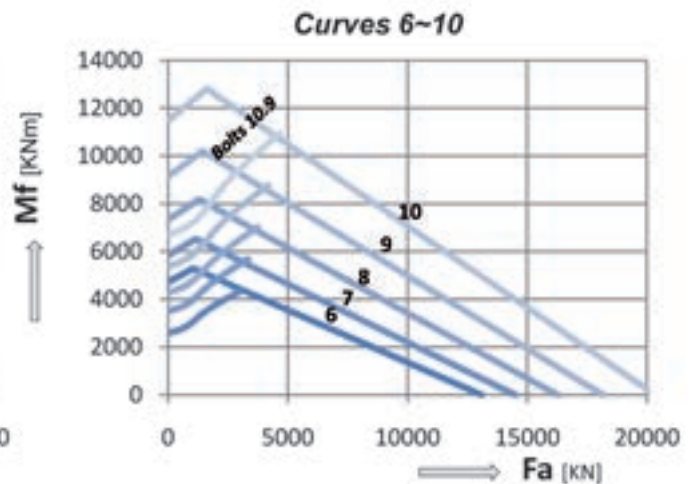
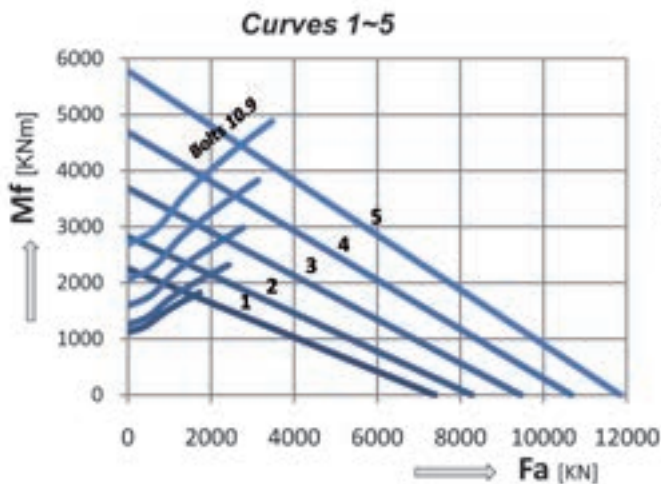

NOTA: necessario sempre comunicare i carichi per una corretta selezione - NOTE: always communicate load cases for an appropriate selection

ER3.32/40

SERIE STANDARD

STANDARD SERIES

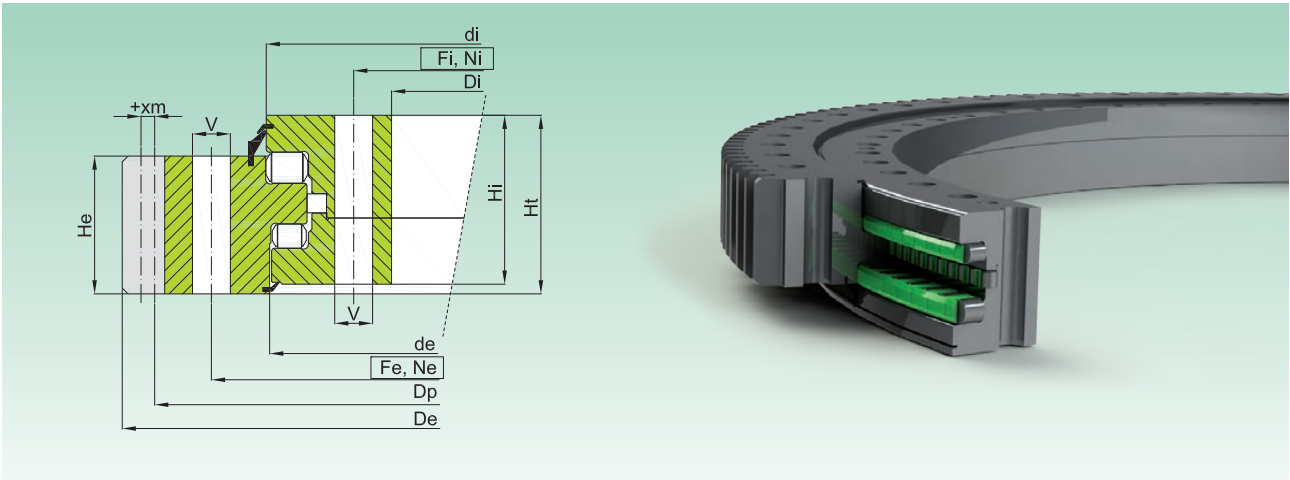

Codice Code	Curva Curve	Dimensioni Dimensions							Fori di fissaggio Fixing Holes				Dentatura Gear data					Peso Weight [kg]	
		De [mm]	de [mm]	di [mm]	Di [mm]	He [mm]	Hi [mm]	Ht [mm]	Fe [mm]	Fi [mm]	N [-]	V [mm]	m [mm]	Z [-]	xm [mm]	Dp [mm]	fz norm [kN]		fz max [kN]
ER3.32.2240.400-1SPPN	1	2552,4	2270	2281	2022	139	172	181	2395	2100	40	39	18	139	+0,50	2502	228	401	1975
ER3.32.2500.400-1SPPN	2	2822,4	2530	2541	2282	139	172	181	2655	2360	44	39	18	154	+0,50	2772	228	401	2260
ER3.32.2800.400-1SPPN	3	3136	2830	2841	2582	139	172	181	2955	2660	48	39	20	154	+0,50	3080	260	465	2576
ER3.32.3150.400-1SPPN	4	3476	3180	3191	2932	139	172	181	3305	3010	56	39	20	171	+0,50	3420	260	465	2828
ER3.32.3550.400-1SPPN	5	3889,6	3580	3591	3332	139	172	181	3705	3410	66	39	22	174	+0,50	3828	295	525	3249
ER3.32.4000.400-1SPPN	6	4351,6	4030	4041	3782	139	172	181	4155	3860	72	39	22	195	+0,50	4290	295	525	3752
ER3.40.2800.400-1SPPN	7	3136	2837	2850	2562	170	210	220	2965	2640	48	39	20	154	+0,50	3080	296	525	3267
ER3.40.3150.400-1SPPN	8	3515,6	3187	3200	2912	170	210	220	3315	2990	56	39	22	157	+0,50	3454	338	605	3812
ER3.40.3550.400-1SPPN	9	3911,6	3587	3600	3312	170	210	220	3715	3390	66	39	22	175	+0,50	3850	338	605	4255
ER3.40.4000.400-1SPPN	10	4363,2	4037	4050	3762	170	210	220	4165	3840	72	39	24	179	+0,50	4296	380	685	4805
ER3.40.4500.400-1SPPN	11	4867,2	4537	4550	4262	170	210	220	4665	4340	84	39	24	200	+0,50	4800	380	685	5410

- Materiale: 42CrMo4 Q+T
- Costruite con gioco positivo
- Pieni di grasso, protetti da olio, e avvolti in resistente film plastico

- Material 42CrMo4 Q+T
- Assembled with positive clearances
- Full of grease, protected by oil and wrapped in resistant plastic film



Diagramma di carico statico valido per sforzi compressivi
Static load charts valid for compressive loads



Carico sospeso: occorre verifica specifica della bulloneria
Suspended load: specific bolts calculation required

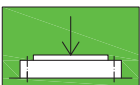
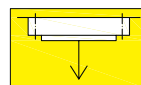
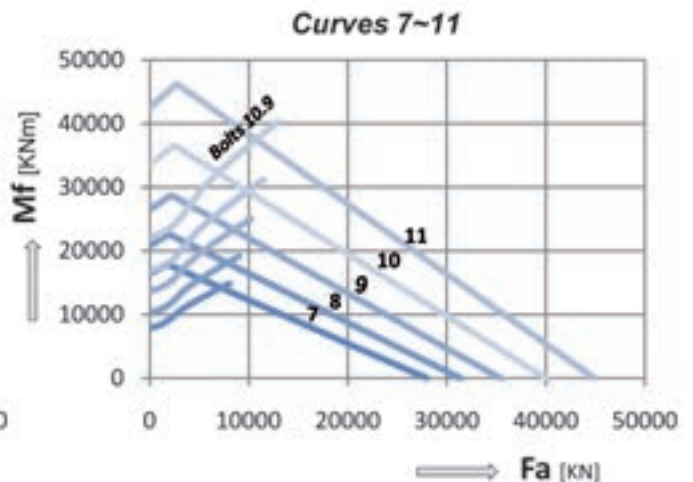
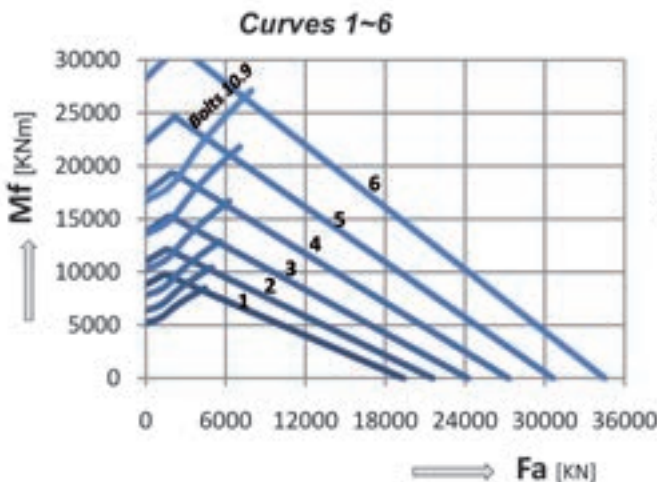

NOTA: necessario sempre comunicare i carichi per una corretta selezione - NOTE: always communicate load cases for an appropriate selection