

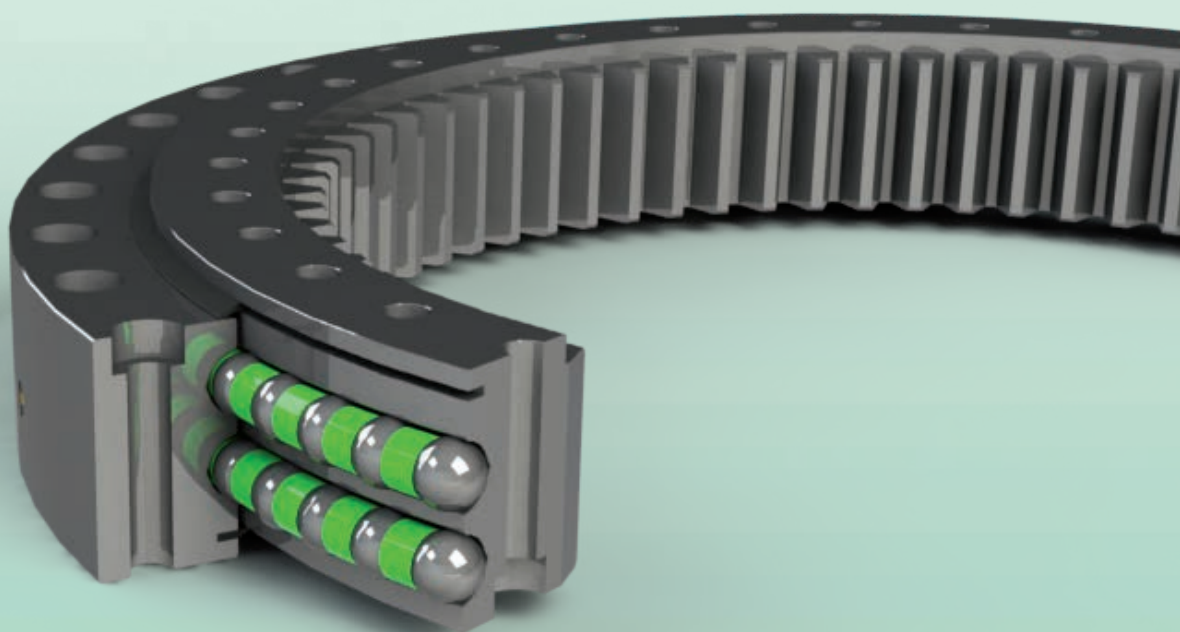

Cuscinetti di base a due giri di sfere, dentatura interna

Double row ball bearing, internal toothed



ZB2 SERIES

ZB2

SERIE STANDARD

STANDARD SERIES

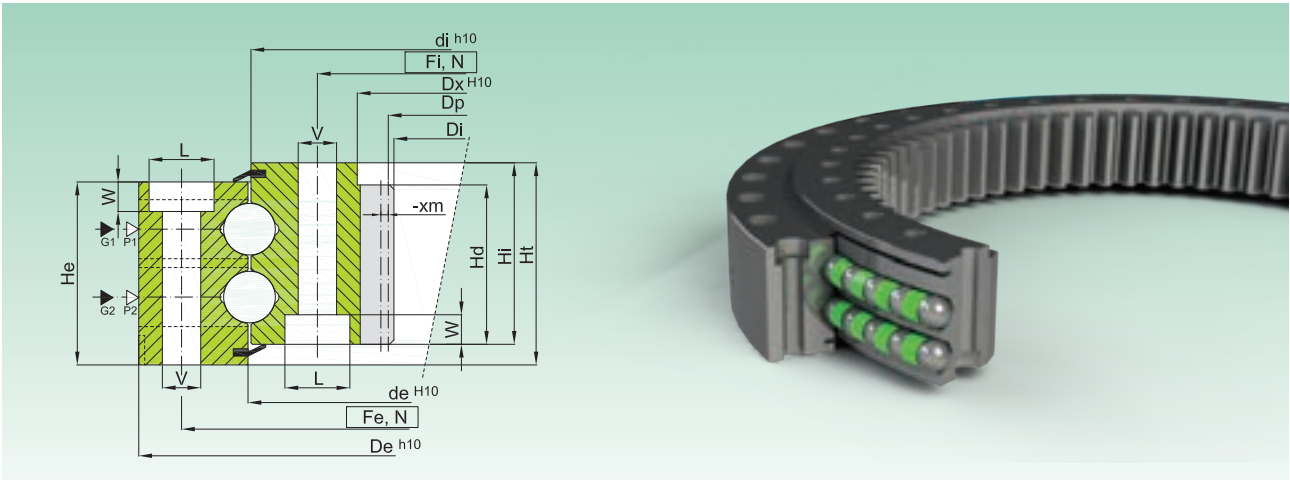

Codice Code	Curva Curve	Dimensioni Dimensions								Fori di fissaggio Fixing Holes					Dentatura Gear data				Peso Weight [kg]				
		De [mm]	de [mm]	di [mm]	Di [mm]	Dx [mm]	He [mm]	Hi [mm]	Ht [mm]	Hd [mm]	Fe [mm]	Fi [mm]	N [-]	V [mm]	L [mm]	W [mm]	m [mm]	Z [-]		xm [mm]	Dp [mm]	fz norm [kN]	fz max [kN]
ZB2.22.0625.400-1RPPN	1	705	627	623	504	547	83	83	92	74	675	575	32	17	25	9	8	65	-	520	49,3	98,6	95
ZB2.22.0763.400-1RPPN	2	850	765	761	641	-	83	83	92	83	820	705	36	17	25	17	8	81	-4	648	64,2	128,4	128
ZB2.20.0897.200-1SPPN	3	973	899	895	786	820	88	88	97	80	944	850	36	17	25	11	8	100	-	800	45,3	90,6	141
ZB2.22.0885.400-1RPPN	4	982	887	883	754	790	88	88	97	80	944	826	36	21	31	14	8	95	-4	760	61,8	123,6	170
ZB2.25.0972.400-1SPPN	5	1074	974	970	820	-	100	96	114	96	1035	910	40	21	-	-	10	84	-	840	76,0	152,0	234
ZB2.22.1088.200-1RPPN	6-a	1172	1090	1085	962	1010	88	88	97	80	1134	1040	36	17	25	11	10	98	-	980	56,7	113,4	193
ZB2.22.1088.201-1RPPN	6-b	1172	1090	1085	962	1010	88	88	97	80	1134	1040	48	17	25	11	10	98	-	980	56,7	113,4	189
ZB2.22.1088.400-1RPPN	6-a	1172	1090	1085	962	1010	88	88	97	80	1134	1040	36	17	25	11	10	97	-5	970	77,3	154,6	193
ZB2.25.1103.200-1SPPN	7	1200	1105	1099	963	1010	96	96	110	88	1160	1040	36	21	31	12	10	98	-	980	62,3	124,6	239

- Materiale: .400:=42CrMo4 Q+T / .200=C45 Q+T

- Gioco assiale e radiale riportati sul disegno tecnico

- Possibilità di dentatura temprata (-1RPPN)

▷ P1, P2 = tappo inserimento sfere / filling plug

▶ G1, G2 = n.2+2 ingrassatori / n.2+2 greasers

- Material: .400:=42CrMo4 Q+T / .200=C45 Q+T

- Axial/radial clearances are on the technical drawing

- Induction gear hardening available on request (-1RPPN)



Diagramma di carico statico valido per sforzi compressivi
Static load charts valid for compressive loads



Carico sospeso: occorre verifica specifica della bulloneria
Suspended load: specific bolts calculation required

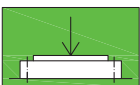
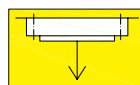
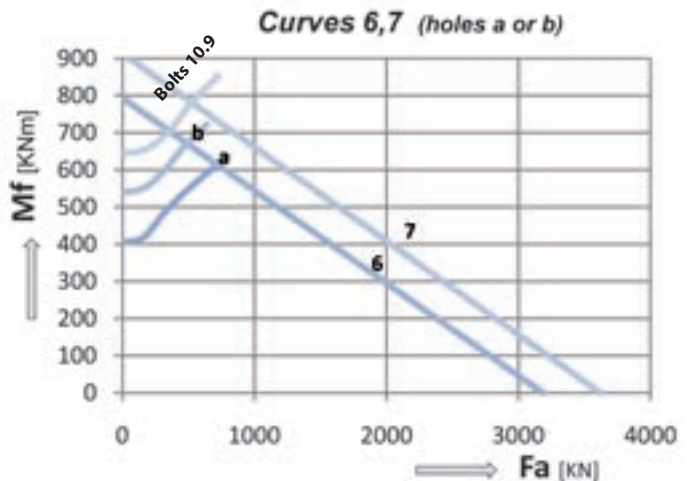
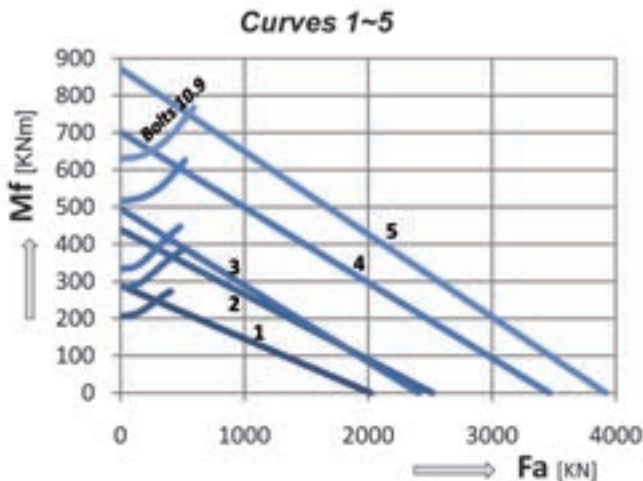

NOTA: controllare se carico radiale presente e consultare parte 2 del catalogo - NOTE: check if radial load applied and consult part 2 of the catalogue

ZB2

SERIE STANDARD

STANDARD SERIES

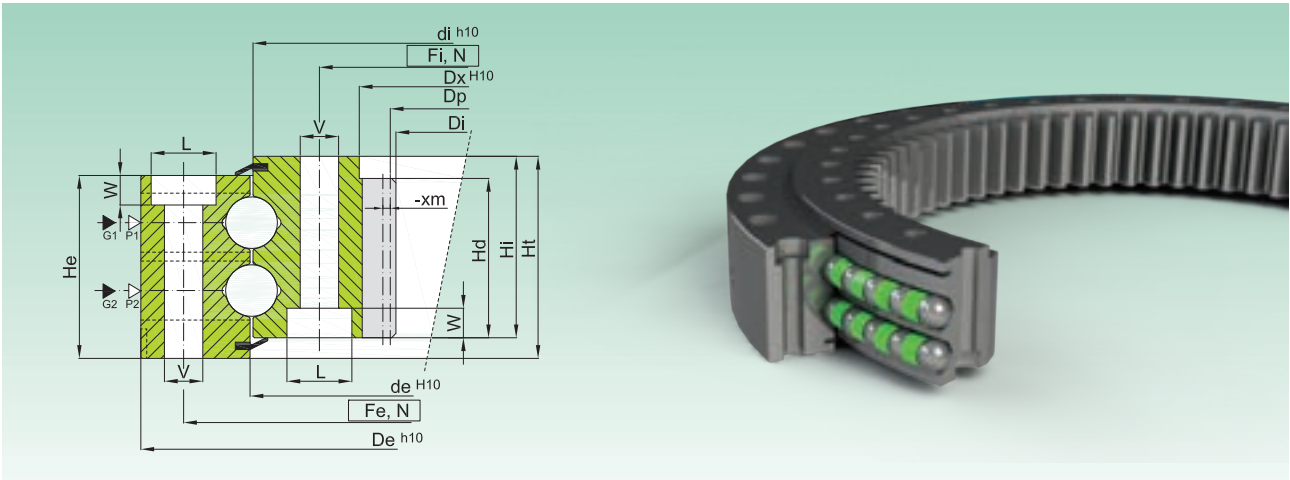

Codice Code	Curva Curve	Dimensioni Dimensions								Fori di fissaggio Fixing Holes					Dentatura Gear data				Peso Weight [kg]				
		De [mm]	de [mm]	di [mm]	Di [mm]	Dx [mm]	He [mm]	Hi [mm]	Ht [mm]	Hd [mm]	Fe [mm]	Fi [-]	N	V [mm]	L [mm]	W [mm]	m [mm]	Z [-]		xm [mm]	Dp [mm]	fz norm [kN]	fz max [kN]
ZB2.25.1103.400-1SPPN	1-a	1200	1105	1099	963	1010	96	96	110	88	1160	1040	36	21	31	12	10	98	-	980	73,3	146,6	239
ZB2.25.1103.401-1SPPN	1-b	1200	1105	1099	963	1010	96	96	110	88	1160	1040	48	21	31	12	10	98	-	980	73,3	146,6	232
ZB2.30.1143.400-1SPPN	2	1250	1147	1141	998	-	99,5	99,5	110	99,5	1208	1080	36	21	31	12	10	100	-8	1000	91,3	182,6	276
ZB2.28.1222.400-1SPPN	3-a	1345	1225	1219	1061,6	1115	98	98	108	88	1290	1150	40	21	31	16	10	108	-	1080	73,3	146,6	331
ZB2.28.1222.401-1SPPN	3-b	1345	1225	1219	1061,6	1115	98	98	108	88	1290	1150	48	21	31	16	10	108	-	1080	73,3	146,6	326
ZB2.30.1351.400-1SPPN	4-a	1470	1354	1348	1183	1230	98	98	108	90	1425	1270	40	23	34	18	10	120	-	1200	71,2	142,4	371
ZB2.30.1351.401-1SPPN	4-a	1470	1354	1348	1179	1230	98	98	108	90	1425	1270	40	23	34	18	12	100	-	1200	85,5	171,0	371
ZB2.30.1351.402-1SPPN	4-b	1470	1354	1348	1183	1230	98	98	108	90	1425	1270	48	23	34	18	10	120	-	1200	71,2	142,4	365
ZB2.30.1351.403-1SPPN	4-b	1470	1354	1348	1179	1230	98	98	108	90	1425	1270	48	23	34	18	12	100	-	1200	85,5	171,0	365

- Materiale: 42CrMo4 Q+T

- Gioco assiale e radiale riportati sul disegno tecnico

- Possibilità di dentatura temprata (-1RPPN)

▷ P1, P2 = tappo inserimento sfere / filling plug

- Material : 42CrMo4 Q+T

- Axial/radial clearances are on the technical drawing

- Induction gear hardening available on request (-1RPPN)

▶ G1, G2 = n.2+2 ingrassatori / n.2+2 greasers.



Diagramma di carico statico valido per sforzi compressivi
Static load charts valid for compressive loads



Carico sospeso: occorre verifica specifica della bulloneria
Suspended load: specific bolts calculation required

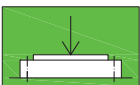
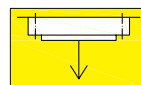
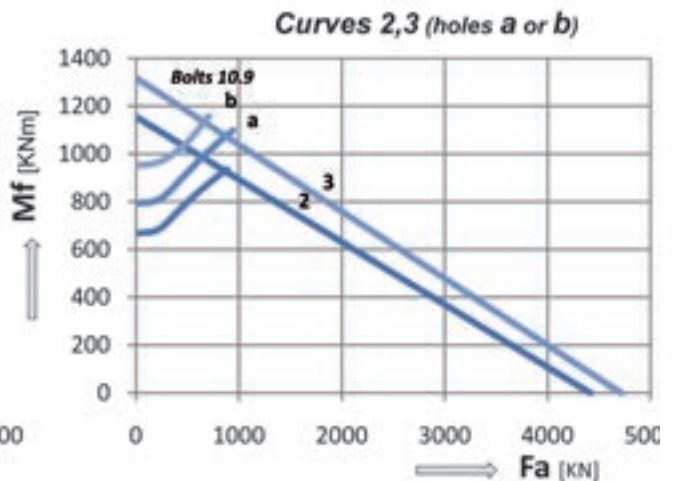
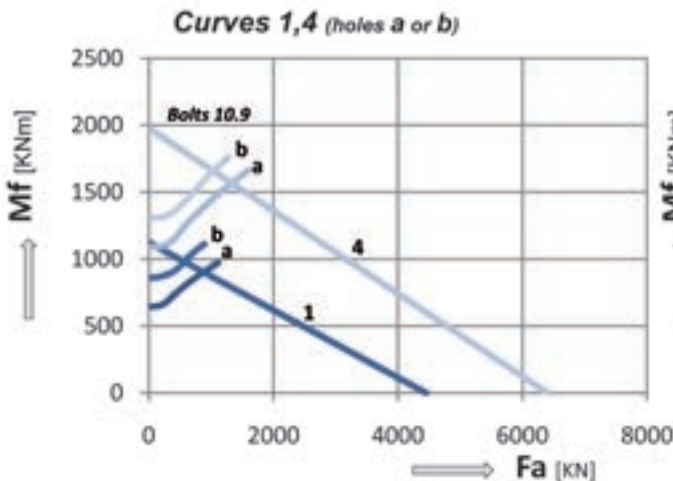

NOTA: controllare se carico radiale presente e consultare parte 2 del catalogo - NOTE: check if radial load applied and consult part 2 of the catalogue

ZB2

SERIE STANDARD

STANDARD SERIES

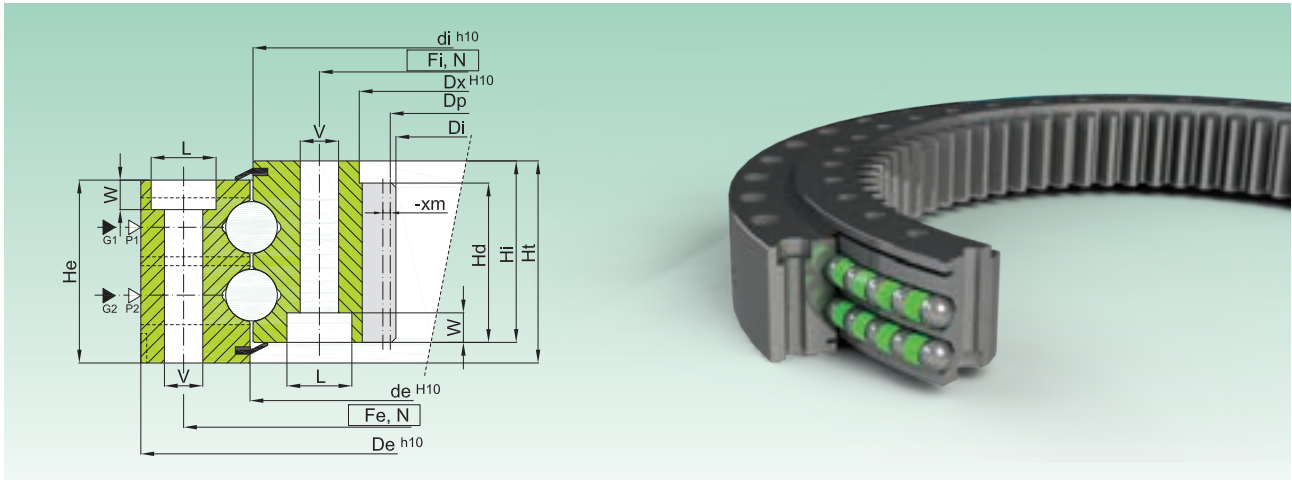

Codice Code	Curva Curve	Dimensioni Dimensions								Fori di fissaggio Fixing Holes					Dentatura Gear data				Peso Weight [kg]				
		De [mm]	de [mm]	di [mm]	Di [mm]	Dx [mm]	He [mm]	Hi [mm]	Ht [mm]	Hd [mm]	Fe [mm]	Fi [-]	N [mm]	V [mm]	L [mm]	W [mm]	m [mm]	Z [-]		xm [mm]	Dp [mm]	fz norm [kN]	fz max [kN]
ZB2.40.1386.400-1SPPN	1	1530	1389	1383	1186	1240	134	134	144	109	1480	1290	48	25	37	23	10	120	-3	1200	100,0	200,0	612
ZB2.40.1386.401-1SPPN	1	1530	1389	1383	1186	1240	134	134	144	119	1480	1290	48	25	37	23	12	100	-	1200	113,0	226,0	627
ZB2.30.1613.200-1SPPN	2	1750	1616	1610	1418,4	1470	110	105	120	98	1705	1525	40	25	37	23	12	120	-	1440	83,3	166,6	572
ZB2.30.1613.400-1SPPN	3	1750	1616	1610	1418,4	1470	110	105	120	98	1705	1525	48	25	37	23	12	120	-	1440	93,1	186,2	564
ZB2.45.1605.400-1SPPN	4	1780	1606	1602	1375	1438	134	134	144	124	1710	1500	48	31	46	28	14	100	-	1400	137,4	274,8	840
ZB2.45.1605.401-1SPPN	4	1780	1606	1602	1375	1382	134	134	144	124	1710	1500	48	31	46	28	12	117	-	1404	117,8	235,6	832
ZB2.35.1935.400-1SPPN	5	2100	1938	1932	1719	1774	134	134	144	120	2035	1835	72	29	-	-	12	145	-	1740	114,0	228,0	965
ZB2.35.2003.400-1SPPN	6	2178	2006	2000	1779	1835	134	134	144	120	2108	1898	72	29	-	-	12	150	-	1800	114,0	228,0	1062

- Materiale: 42CrMo4 Q+T

- Gioco assiale e radiale riportati sul disegno tecnico

- Possibilità di dentatura temprata (-1RPPN)

▷ P1, P2 = tappo inserimento sfere / filling plug

▷ G1, G2 = n.2+2 ingrassatori / n.2+2 greasers.

- Material : 42CrMo4 Q+T

- Axial/radial clearances are on the technical drawing

- Induction gear hardening available on request (-1RPPN)



Diagramma di carico statico valido per sforzi compressivi
Static load charts valid for compressive loads

Curves 1,4,5,6

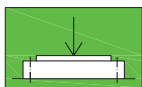
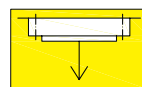
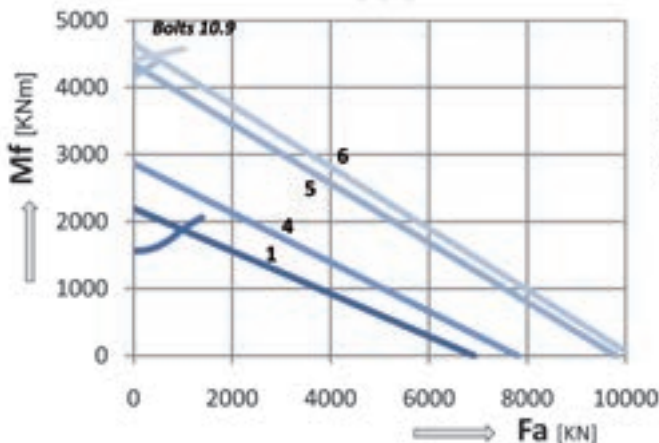

Carico sospeso: occorre verifica specifica della bulloneria
Suspended load: specific bolts calculation required

Curves 2,3

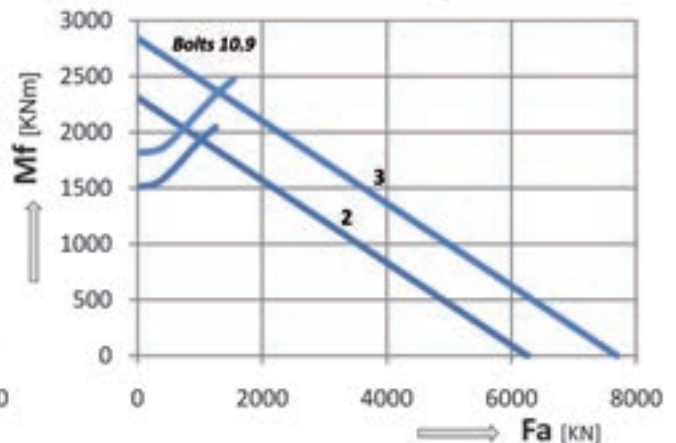

NOTA: controllare se carico radiale presente e consultare parte 2 del catalogo - NOTE: check if radial load applied and consult part 2 of the catalogue