



MAIN FEATURES

This board is used when it is necessary to select a signal among a maximum of 3 inputs.

The EMD board accepts input signals coming from a maximum of 3 encoders and provides as output the signals of one of these encoders.

Output signals are selected connecting properly the two inputs, in1 and in2, according to the operating diagram (see next page).

EMD and encoder electronics must be indicated in the ordering code and the electronic interfaces of the connected encoders must be all identical. Moreover the EMD provides 3 contacts normally open that close when respective input is selected.

The following example is needful to understand better the use of this board.

We would like to read the signals of 3 encoders (or other devices with similar features) in sequential way. Encoders must have same output electronics, for example 5 V DC line driver. The instrument for data acquisition, on the contrary, has a different electronic interface, for example 24 V DC push-pull.

In this case the EMD board will perform the selection function among the connected encoders and the matching of the electronic interfaces.

The ordering code will be:

EMD5L8/24P, where EMD5L indicates that inputs are 5 V DC line driver, EMD5L8/24P indicates that output is 8÷24 V DC push-pull. EMD power supply must be the highest value among requested voltages: in this case 8÷24 V DC. The encoder selection is carried out through a logic type signal at in1 and in2 inputs on the terminal board.

Logic level “1” is obtained connecting a voltage included between 5 and 24 V DC to above mentioned inputs.

Logic level “0”, instead, is correctly interpreted if voltage is included between 0 and 3 V DC. The combination of logic levels at in1 and in2 inputs sets outputs to 4 different states, as described in the table in the following page.

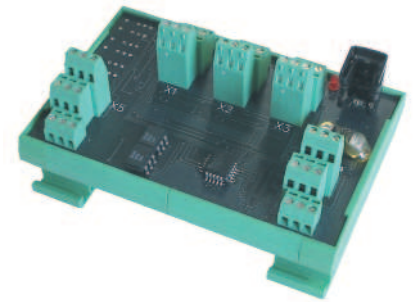

ORDERING CODE

	in		out		
	5	L	8/24	P	.XXX
SERIES	EMD				
signal selector	EMD				
INPUT VOLTAGE X1 / X2 / X3 CONNECTOR	5 V DC 5				
	8 ... 24 V DC 8/24				
INPUT ELECTRONICS X1 / X2 / X3 CONNECTOR	(8 ... 24V) push-pull P				
	line driver L				
OUTPUT VOLTAGE X4 CONNECTOR	5 V DC 5				
	8 ... 24 V DC 8/24				
OUTPUT ELECTRONICS X4 CONNECTOR	push-pull P				
	line driver L				
VARIANT	custom version XXX				

TERMINAL BOARD CONNECTIONS

terminal board connections
encoder inputs 1 / 2 / 3

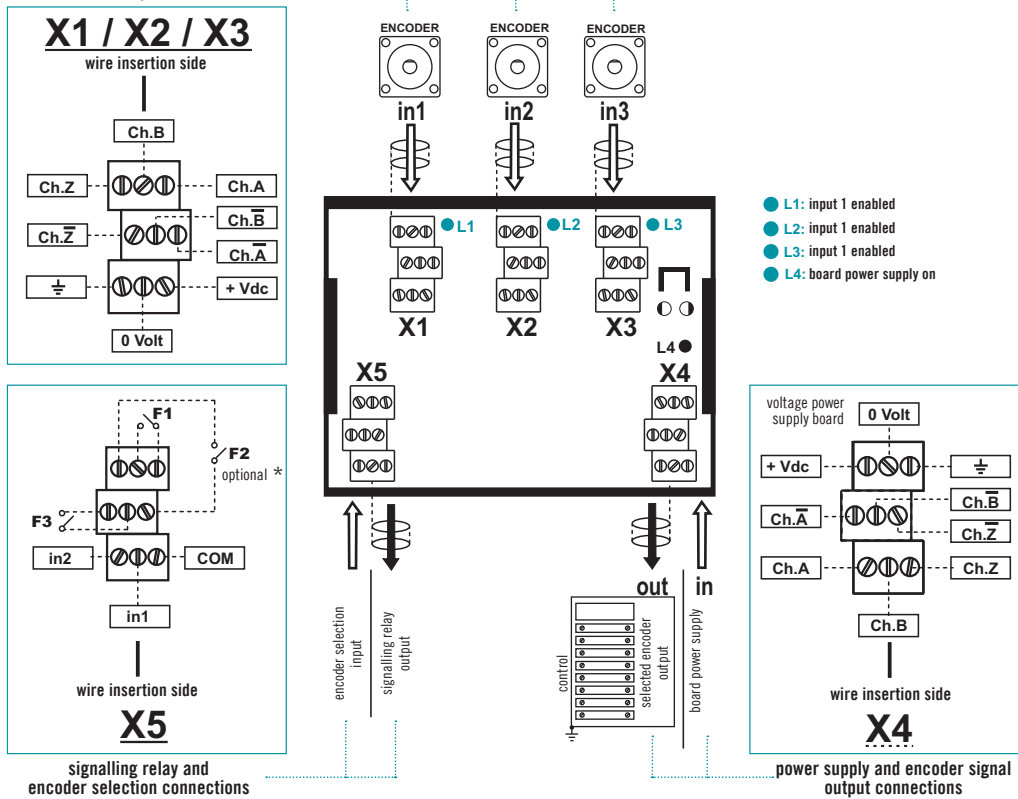

F1, F2, F3 = relay

* with relay please add 726 as variant

LOGIC STATES

Logic state on X5		Selected encoder on X4			Selected contact on X5 (with variant 726)		
in1	in2	X1	X2	X3	F1	F2	F3
0	0	-	-	-	-	-	-
1	0	•	-	-	•	-	-
0	1	-	•	-	-	•	-
1	1	-	-	•	-	-	•

ELECTRICAL SPECIFICATIONS

Power supply	5 = 4,5 ... 5,5 V DC 8/24 = 7,6 ... 25,2 V DC
Current consumption without load	150 mA max
Max load current	20 mA / channel (line driver) 40 mA / channel (push-pull)
Max input current	10 mA for channel
Input logic levels in1 and in2	"1" = 5 ... 24 V DC "0" = 0 ... 3 V DC
Contact characteristics	Vmax = 125 V AC / 60 V DC Imax = 0,5 A Vmin = 5 V DC Imin = 1 mA
Operating temperature	0° ... +40°C (+32° ... +104°F)
Storage temperature	-10° ... +60°C (+14° ... +140°F)
Fixing on panel	DIN 46277-3 rail (Omega) DIN 46277-2 rail (Omega)

MECHANICAL DIMENSIONS

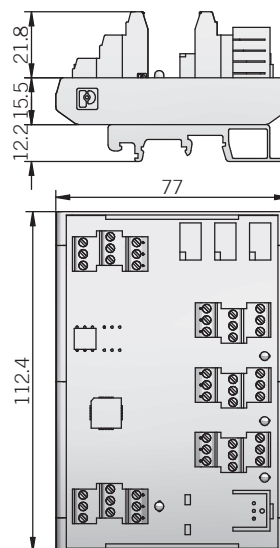

dimensions in mm